



Home of the Tualatin River National Wildlife Refuge

2nd & Park Regional Storm Facility Rehab Project

BID SET
April 2026



EXPIRES: 12-31-27

Project Number: 502
Bidding and General Requirements, Contract Forms,
Project Special Provisions and Contract Plans

Owner
City of Sherwood
Engineering Department
22560 SW Pine Street
Sherwood, OR 97140
(503) 925-2309

Division One

Bidding Requirements

TABLE OF CONTENTS

VOLUME 1 OF 2

Division One – Bidding Requirements

- Invitation to Bid
- Bidder's Checklist
- Bid Statement
- Bid Schedule
- First-Tier Subcontractor Disclosure Form
- Bid Bond
- Certification of Non-collusion
- Certification of Compliance with ORS 279C.840 (Prevailing Wages)
- Certification of Asbestos Abatement
- Certification of Non-Discrimination
- Customer Service Acknowledgment
- Prequalification Acknowledgment
- Bidder Responsibility Form
- Addendum (Example)

Division Two – Contract Forms

- Contract Agreement (Example)
- Performance Bond
- Payment Bond
- State of Oregon Statutory Public Works Bond
- Notice of Intent to Award (Example)
- Notice of Award (Example)
- Notice of Award to BOLI (Example)
- Notice to Proceed (Example)

Division Three – General Requirements

- BOLI Wage Rates (Cover Sheet Only)
- General Requirements

Division Four – Special Provisions

- Special Provisions

Division Five – Supplemental Information

- 2006 Storm Facility As Built Plans
- 2013 Storm Facility Rehab As Built Plans

VOLUME 2 OF 2

Contract Drawings

- 2nd & Park Regional Storm Facility Rehab Project – Contract Drawings

INVITATION TO BID
City of Sherwood
2nd & Park Regional Storm Facility Rehab Project

Sealed bids for furnishing all materials, equipment, labor, and services for the construction of the **2nd & Park Regional Storm Facility Rehab Project** for the City of Sherwood will be received at City of Sherwood, Engineering Department, 22560 SW Pine Street, Sherwood, Oregon 97140 (Attn: Sofi Lam, P.E., Project Manager) until the **Bid Closing at 2:00 PM (local time) on Thursday, April 9, 2026**. Please title the envelope 2nd & Park Regional Storm Facility Rehab Project. Bids will then be publicly opened and read aloud after 2:00 PM at the Sherwood City Hall Community Room, 22560 SW Pine Street, Sherwood, Oregon. This project is subject to a pre-qualification process and contractors must be pre-qualified in Landscaping or Earthwork and Drainage. No bids will be accepted after the **BID CLOSING** time.

First-Tier Subcontractor Disclosure forms must be received at the above-mentioned location and date no later than **4:00 PM (Local Time)**. Proposals without a completed First-Tier Subcontractor Disclosure form submitted will be considered non-responsive.

A MANDATORY PRE-BID MEETING WILL BE HELD FOR THIS PROJECT on Tuesday, March 17th, 2026, at 2:00 PM (local time) at Sherwood City Hall, Community Room, 22560 SW Pine Street, Sherwood, OR 97140.

Bidders must be **pre-qualified** in accordance with the laws of the State of Oregon (ORS 279C.430) to do either Landscaping or Earthwork and Drainage Improvements. Letters of pre-qualification (approval letter only) from the Oregon Department of Transportation (ODOT), Washington County Department of Land Use & Transportation, or any local municipality with a population equal to or greater than 18,000 persons is acceptable to the City. Proof of valid pre-qualification must be submitted to the City by **Tuesday, April 7, 2026, at 5:00 PM (Local Time)** for the Bidder's bid to retain appeal rights.

Project Description

The Work to be done under this Contract consists of the construction of the following items:

1. Concrete weir box modifications.
2. Riprap removal and reuse.
3. Regrading of stormwater facility.
4. Removal and reconstruction of concrete flow spreaders.
5. Removal and replanting of storm facility vegetation.
6. 2-Year Plant Establishment.
7. Traffic control.
8. Utility vault lid and weir box riprap removal (bid alternate).
9. Other miscellaneous items for completion of work.
10. Engineer's Estimate, including alternate (\$160,000-\$230,000)

Bidding Documents and Contract Drawings are available for free download on www.sherwoodoregon.gov/business-development/rfps/ and are acceptable for Bid Submittal.

Other locations Bidding Documents may be examined:

- DJC Plan Center (Electronic only), 503-224-0624, Email: plancenter@djcoregon.com
- Oregon Contractors Plan Center, 5468 SE International Drive, Milwaukie, OR 97222
- Builders Exchange of Washington, Inc., 2607 Wetmore Ave., Everett, WA 98201

official Planholders list by sending an email to engineering@sherwoodoregon.gov. Bidders are not required to be on Planholders list to submit a Bid for this project.

Addenda, clarifications and notices will be posted online on the City's website. Potential Bidders are responsible for checking the website on a daily basis. Each addendum must be signed and submitted with the Bid to be considered a responsive bid offer. The City is not responsible for failure of bidders to receive notifications of changes or corrections made by the City and posted as stated above.

Questions shall be submitted BY EMAIL ONLY to lams@sherwoodoregon.gov (cc christensenc@sherwoodoregon.gov) by **5:00 P.M. (local time) on Friday, March 27th, 2026**. A log of all questions received and answers provided via email will be memorialized via addendum no later than 48-hours prior to the Bid Opening date & time.

This is a local public works project subject to BOLI prevailing wages (ORS 279C.800 to ORS 279C.870).

Bids shall be accompanied by a certified check, cashier's check or bid bond payable to the City of Sherwood in an amount equal to ten percent (10%) of the amount bid.

The City of Sherwood may reject a bid that does not comply with prescribed public contracting procedures and requirements, including the requirement to demonstrate the bidder's responsibility under ORS 279C.375(3)(b), and that the City may reject for good cause, all bids after finding that doing so is in the public interest. City reserves the right to waive minor informalities in any bid.

Schedule:

- 03/11/26 & 03/13/26 DJC Advertisement
- 03/17/26, 2:00 pm Pre-Bid Meeting
- 03/27/26, 5:00 pm Questions Due
- 04/03/26, 2:00 pm Responses to Questions will be Posted
- 04/07/26, 5:00 pm Pre-Qualifications Due
- 04/09/26, 2:00 pm Bid Closing
- 04/09/26, 4:00 pm First-Tier Subcontractor Disclosure Forms Due

For more information regarding this project, contact Sofi Lam, P.E., at 503.925.2303 or by email at lams@sherwoodoregon.gov.

PUBLISH: Portland Daily Journal of Commerce, Wednesday, March 11, 2026 and Friday, March 13, 2026.

BIDDER'S CHECKLIST

2nd & Park Regional Storm Facility Rehab

- Bid Statement including signed signature page
- Bid Schedule
- First Tier Subcontractor Disclosure Form
- Bid Bond (original copy)
- Certification of Non-Collusion
- Certification of Compliance with ORS 279C.840
- Certification of Asbestos Abatement
- Certification of Non-Discrimination
- Customer Service Acknowledgment
- Prequalification Acknowledgement
- Bidder Responsibility Form
- All Applicable Addenda

BID STATEMENT

The undersigned Bidder declares:

That Bidder has carefully examined and incorporates in this Bid, by this reference all documents included in the Bid Booklet of Contract Documents and Specifications for this job, which includes but is not limited to the Plans, Standard Specifications and Standard Drawings, Supplemental Specifications and Special Provisions, Addenda, Bid Schedule, Prevailing Wage Rates, Contract form, Bond forms, and Conditions of the Contract for:

2nd & Park Regional Storm Facility Rehab

That Bidder has made an examination of the site of the proposed work and has made such investigations as are necessary to determine the character of the material and the conditions to be encountered, independently of the indication on the plans; and that if the Proposal is accepted, Bidder will contract with the City of Sherwood as provided in the Contract form, will to the extent of this bid, provide the necessary machinery, tools, apparatus, and other means of construction, and will furnish all material and labor as specified, or called for by the Plans or as necessary to complete the work in the manner specified and in accordance with the requirements of the Engineer.

The undersigned has checked carefully all the bid schedule figures and understands that the City will not be responsible for any errors or omissions on the part of the undersigned in making this bid.

That Bidder has carefully studied all reports of explorations and tests of subsurface conditions at or contiguous to the site and all drawings of physical conditions in or relating to existing surface or subsurface structures at or contiguous to the site which have been identified in the Solicitation Documents. Bidder acknowledges that such reports and drawings are not Contract Documents and may not be complete for Bidder's purposes. Bidder acknowledges that City and Architect/Engineer do not assume responsibility for the accuracy or completeness of information and data shown or indicated in the Bidding Documents with respect to Underground Facilities at or contiguous to the site.

That Bidder has obtained and carefully studied (or assumes responsibility for having done so) all additional or supplementary examinations, investigations, explorations, tests, studies and data concerning conditions (surface, subsurface and underground facilities) at or contiguous to the site which may affect cost, progress, or performance of the work and which relate to any aspect of the means, methods, techniques, sequences, and procedures of construction expressly required by the Bidding Documents to be employed by Bidder, and safety precautions and programs incident thereto.

That Bidder does not consider that any additional examinations, investigations, explorations, tests, studies or data are necessary for the determination of this Bid for performance furnishing of the work in accordance with the times, price and other terms and conditions of the Contract Documents.

Bidder has given Architect/Engineer written notice of all conflicts, errors, ambiguities or discrepancies that Bidder has discovered in the Contract Documents and the written resolution thereof by Architect/Engineer is acceptable to Bidder, and the Contract Documents are generally sufficient to and convey understanding of all terms and conditions for performing and furnishing the work for which this Bid is submitted.

The undersigned also agrees that Bidder will order all material and equipment included under this contract and will commence work within ten (10) days after receipt of Notice to Proceed and that Bidder will complete the work in all respects after commencement and will have the project completed by the

date specified in the special provisions and that Bidder will pay as liquidated damages to the City for any delay, the sum of **Eight Hundred and No/100 Dollars (\$800.00)** per day for each Calendar Day required beyond that period.

Accompanying this proposal is a Certified Check, Cashier's Check, or Bidder's Bond

from _____ of _____
(Name of Surety) (City/State)

in the amount of _____ dollars

(\$ _____), being 10% of the amount bid according to the conditions of the Call for Bids and Specifications.

If this proposal should be accepted by the City and the undersigned should fail to executed a satisfactory contract and bond within ten (10) days from the date of notification, then the City may, as stated in the specifications, determine that the undersigned has abandoned the contract and thereupon this proposal shall be null and void, and the certified check, cashier's check or Bidder's bond accompanying this proposal shall be forfeited to and become the property of the City. Otherwise, the certified check, cashier's check or Bidder's bond accompanying this proposal shall be returned to the undersigned.

The full name and residence of all parties and persons interested in this bid as principals are as follows:

| NAME | RESIDENCE |
|-------|-----------|
| _____ | _____ |
| _____ | _____ |

The name and business address of the surety company which will furnish the required performance and payments bonds is

(Name of Surety Company) (Number and Street Address) (City / State / Zip)

All General and Specialty Construction Contractors must have a valid Certificate of Registration with the Construction Contractors Board/State Landscape Contractors Board in order to submit a Bid or offer to undertake any Construction Work in the State of Oregon (ORS 701.026/ORS 671.530).

REGISTRATION NO. _____ **EXPIRATION DATE** _____

The undersigned Bidder has heretofore completed the following work of a similar nature to that contemplated.

| JOB | LOCATION | DATE |
|-----|----------|------|
| | | |
| | | |
| | | |
| | | |

The undersigned Bidder acknowledges that the amount of damages City might suffer by reason of a failure to complete the project by the Completion Date noted above would be difficult or impossible to compute, and therefore agrees that the stipulated amount of liquidated damages set forth above for such delay is a fair and reasonable measure of damages, and therefore Bidder agrees that it will not contest such sum as being other than a true measure of damages in the event of a failure to complete the project by the stipulated Completion Date. Bidder hereby declares and agrees:

- (1) that this is a local public works project subject to the state prevailing rates of wage under ORS 279C.800 to 279C.870, no bid will be considered without statement by the bidder that the bidder will comply with ORS 279C.838 or 279C.840;
- (2) that Bidder is _____ is not _____ a Resident of Oregon Bidder, as defined by ORS 279A.120. "Resident Bidder" means a Bidder that has paid unemployment taxes or income taxes in this state during the 12-calendar months immediately preceding submission of the bid, has a business address in this state, and has stated in the bid whether the Bidder is a "Resident Bidder;"
- (3) that City of Sherwood may reject a bid that does not comply with prescribed public contracting procedures and requirements, including the requirement to demonstrate the bidder's responsibility under ORS 279C.375(3)(b), and the City of Sherwood may reject for good cause all bids after finding that doing so is in the public interest;
- (4) that no Bid will be considered unless the Bidder is registered with the Construction Contractors Board as required by OAR 137-049-230.
- (5) that where asbestos abatement is required the abatement shall be done by Department of Environmental Quality licensed contractor (ORS 468A.720) and the abatement shall be performed in conformity with DEQ and OSHA regulations and other standards related to work place safety;
- (6) that Bidder shall comply with and cause its subcontractors to comply with all applicable provisions of federal, state and local statutes, ordinances, rules and regulations;
- (7) that Bidder shall comply with pre-qualification conditions in accordance with the laws of the State of Oregon (ORS 279C.430) as follows:
 - a. Pre-qualification is required and forms must be filed two (2) days prior to the Bid Opening date for the Bidder to retain bidding rights.
 - b. Required forms: Proof of pre-qualification acceptance by either the State of Oregon Department of Transportation (ODOT), Washington County Department of Transportation, or any local major municipality is acceptable to the City. Bidders may mail (address on cover sheet), fax (503-625-0629) or e-mail

(engineering@sherwoodoregon.gov) proof of pre-qualification to the City, to the attention of the City Engineer.

- (8) that each Bidder must provide certification of non-discrimination in obtaining required subcontractors in accordance with ORS 279A.110(4).
- (9) that Bidder must also possess either a Metro license or a City of Sherwood business license at the time of construction.
- (10) that all principal individuals in your organization assigned to the project (superintendent, project manager, and/or lead on-site contact) shall be listed on the Bidder Responsibility Form submitted to the City. Any personnel changes during the Project must be preceded by the submittal of the new individual's experience, and written acceptance by the City, as required on the Bidder Responsibility Form.

This bid is incomplete and shall not be considered unless there is attached hereto a signed and dated complete original of each of the following: Bid Statement, Bid Schedule, First-Tier Subcontractor Disclosure Form, a Certified Check, Cashier's Check or Bid Bond, Certification of Non-collusion, Certification of Compliance with ORS 279C.840, Certification of Asbestos Abatement, Certification of Non-Discrimination, Customer Service Acknowledgment, Prequalification Acknowledgment, Bidder Responsibility Form and all applicable Addenda.

Submitted By:
Name of Bidder: _____
Signature of
Authorized Agent: _____
Title: _____
Business Address of
Bidder: _____
Phone Number: _____
Date: _____

**BID SCHEDULE (BASE)
 2ND & PARK REGIONAL STORM FACILITY REHAB**

| Item No. | Spec Section | Description | Unit | Quantity | Unit Price | Total Cost |
|---|--------------|---|------|----------|------------|------------|
| PART 00200 -- TEMPORARY FEATURES AND APPURTENANCES | | | | | | |
| 1 | 210 | Mobilization | LS | 1 | | |
| 2 | 221 | Temporary Work Zone Traffic Control, Complete | LS | 1 | | |
| 3 | 280 | Erosion Control, Complete | LS | 1 | | |
| PART 00300 – ROADWORK | | | | | | |
| 4 | 305 | Construction Survey Work | LS | 1 | | |
| 5 | 310 | Removal of Structures and Obstructions | LS | 1 | | |
| 6 | 320 | Clearing and Grubbing | LS | 1 | | |
| 7 | 330 | Regrading of Storm Facility | LS | 1 | | |
| 8 | 350 | 30 Mil Impermeable Liner - Swale | SY | 100 | | |
| 9 | 350 | 30 Mil Impermeable Liner - Basin | LS | 1 | | |
| 10 | 390 | Loose Riprap, Class 50 | CY | 20 | | |
| PART 00400 -- DRAINAGE AND SEWERS | | | | | | |
| 11 | 490 | SandSnout | EA | 3 | | |
| 12 | 490 | Weir Box Retrofit | LS | 1 | | |
| PART 00700 – WEARING SURFACES | | | | | | |
| 13 | 759 | Concrete Flow Spreader | EA | 3 | | |
| PART 01000-RIGHT OF WAY DEVELOPMENT AND CONTROL | | | | | | |
| 14 | 1040 | Herbaceous Plant, ½-gal Container | EA | 2720 | | |
| 15 | 1040 | Facility Matting | SY | 270 | | |
| 16 | 1040 | Plant Establishment, 2-Year, \$6,000 Min. | LS | 1 | | |

BASE BID WRITTEN IN WORDS:

_____ DOLLARS AND _____ CENTS

In the event of discrepancy, the amount in words shall dictate.

In accordance with the provisions of the Oregon Standard Specifications for Construction, 2024 Edition as modified by these bid documents, the undersigned Bidder submits the following Bid Schedule with the understanding that City reserves the right to increase, decrease, or completely eliminate quantities as set forth in 00120.20. Also, the Bidder offers to do the work, whether quantities area changed (increased or decreased) in accordance with 00195.20, or not changed, at the unit rate price stated in the following Bid Schedule:

 Signature of Authorized Agent

 Company Name

 Printed Name

 Date

**BID SCHEDULE (ALTERNATE)
 2ND & PARK REGIONAL STORM FACILITY REHAB**

| Item No. | Spec Section | Description | Unit | Quantity | Unit Price | Total Cost |
|--|--------------|----------------------------------|------|----------|------------|------------|
| PART 00300 – ROADWORK | | | | | | |
| ALT1 | 310 | Removal of Riprap | LS | 1 | | |
| PART 00400 -- DRAINAGE AND SEWERS | | | | | | |
| ALT2 | 470 | Utility 8’x16’ Vault Lid | LS | 1 | | |
| ALT3 | 470 | Crane Mobilization for Vault Lid | LS | 1 | | |

ALTERNATE BID WRITTEN IN WORDS:

_____ **DOLLARS AND** _____ **CENTS**

In the event of discrepancy, the amount in words shall dictate.

In accordance with the provisions of the Oregon Standard Specifications for Construction, 2024 Edition as modified by these bid documents, the undersigned Bidder submits the following Bid Schedule with the understanding that City reserves the right to increase, decrease, or completely eliminate quantities as set forth in 00120.20. Also, the Bidder offers to do the work, whether quantities area changed (increased or decreased) in accordance with 00195.20, or not changed, at the unit rate price stated in the following Bid Schedule:

 Signature of Authorized Agent

 Company Name

 Printed Name

 Date

NOTE TO BIDDER: The lowest responsive bidder will be selected from either the Bid Schedule (Base) or the Bid Schedule (Base & Alternate) by the Sherwood City Manager who will determine the best fits the needs of the City of Sherwood.

FIRST-TIER SUBCONTRACTOR DISCLOSURE FORM

(OAR 137-049-0360)

Bids which are submitted by Bid Closing, but for which a required disclosure submittal has not been made by the specified Disclosure Deadline, are not responsive and shall not be considered for Contract award.

PROJECT NAME: **2nd & Park Regional Storm Facility Rehab**

BID CLOSING: Date: **April 9, 2026** Time: **2:00 PM (Local Time)**

FIRST-TIER DISCLOSURE Date: **April 9, 2026** Time: **4:00 PM (Local Time)**

Deliver Form To (Agency): City of Sherwood

Designated Recipient (Person): Sofi Lam, P.E. Phone #: 503-925-2303

Agency's Address: City of Sherwood, City Hall
 22560 SW Pine Street
 Sherwood, OR 97140

INSTRUCTIONS:

The contracting agency will insert "N/A" above if the contract value is not anticipated to exceed \$100,000. Otherwise this form must be submitted either with the bid or within two (2) working hours after the advertised bid closing date and time; but no later than the DISCLOSURE DEADLINE stated above.

Unless otherwise stated in the solicitation, this document shall not be submitted by facsimile. It is the responsibility of bidders to submit this disclosure form and any additional sheets, with the bid number and project name clearly marked, at the location indicated by the specified disclosure deadline. See "Instructions to Bidders".

List below the Name, Category of Work and Dollar Value for each first-tier subcontractor that would be furnishing labor, or labor and material, for which disclosure is required. Enter the word "NONE" if there are no first-tier subcontractors subject to disclosure. ATTACH ADDITIONAL SHEETS IF NECESSARY.

BIDDER DISCLOSURE:

| | SUBCONTRACTOR NAME | CATEGORY OF WORK | DOLLAR VALUE |
|---|--------------------|------------------|--------------|
| 1 | | | |
| 2 | | | |
| 3 | | | |
| 4 | | | |
| 5 | | | |

The above listed first-tier subcontractor(s) are providing labor, or labor and material, with a Dollar Value equal to or greater than:

- a) 5% of the total Contract Price, but at least \$15,000. [If the Dollar Value is less than \$15,000 do not list the subcontractor above] or;
- b) \$350,000 regardless of the percentage of the total Contract Price.

Form Submitted By (Bidder Name): _____

Contact Name: _____ Phone #: _____

BID BOND

We, _____, as "Principal,"
(Name of Principal)

and _____, an _____ Corporation,
(Name of Surety)

authorized to transact Surety business in Oregon, as "Surety," hereby jointly and severally bind ourselves, our respective heirs, executors, administrators, successors and assigns to pay unto the City of Sherwood ("Obligee") the sum of (\$ _____)

_____ dollars.

WHEREAS, the condition of the obligation of this bond is that Principal has submitted its proposal or bid to an agency of the Obligee in response to Obligee's procurement document for the project identified as:

2nd & Park Regional Storm Facility Rehab

which proposal or bid is made a part of this bond by reference, and Principal is required to furnish bid security in an amount equal to ten (10%) percent of the total amount of the bid pursuant to the procurement document and ORS 279C.365(4) for competitive bidding or 279C.400(5) for competitive proposals.

NOW, THEREFORE, if the proposal or bid submitted by Principal is accepted, and if a contract pursuant to the proposal or bid is awarded to Principal, and if Principal enters into and executes such contract within the time specified in the procurement document and executes and delivers to Obligee its good and sufficient performance and payment bonds required by Obligee, as well as any required proof of insurance, within the time fixed by Obligee, then this obligation shall be void; otherwise, it shall remain in full force and effect.

IN WITNESS WHEREOF, we have caused this instrument to be executed and sealed by our duly authorized legal representatives this _____ day of _____, 20__.

PRINCIPAL: _____ **SURETY:** _____

By _____ Signature BY ATTORNEY-IN-FACT:

Official Capacity Name

Attest: _____ Signature
Corporation Secretary

Address

City State Zip Code

Phone Email

CERTIFICATION OF NON-COLLUSION

PROJECT NAME: 2ND & PARK REGIONAL STORM FACILITY REHAB

TO: CITY OF SHERWOOD, A MUNICIPAL CORPORATION OF THE STATE OF OREGON

**STATE OF OREGON)
) SS
COUNTY OF WASHINGTON)**

(Bidder's Firm Name)

I, the undersigned, as [circle one]:

- sole owner
- a partner
- officer of the foregoing corporation
- agent of the above bidder

being first duly sworn on oath, depose and say:

That the attached bid has been arrived at by the bidder, independently, and has been submitted without collusion with, and without any agreement, understanding or planned course of action with, any other contractor, bidder, or vendor on materials, supplies, equipment or services, described in the invitation to bid, designed to limit independent bidding or competition.

The contents of the bid herein presented and made have not been communicated by the bidder or (his) (their) or (its) employees or agents to any person not an employee or agent of the bidder or its surety on any bond furnished with the bid and will not be communicated to any such person prior to the official opening of the bid.

I have fully informed myself regarding the accuracy of the foregoing statements, and the same are made by me based on my personal information.

I have read and understood the Bid Booklet and the Specifications for the attached Bid.

Signature _____

Title _____

Subscribed and sworn before me this _____ day of _____, 20__

My commission expires: _____

Notary Public for Oregon

**CERTIFICATION OF COMPLIANCE WITH ORS 279C.840
(PREVAILING WAGES)**

FOR

Project Name: 2nd & Park Regional Storm Facility Rehab

The undersigned confirms that the provisions of ORS 279C.840 shall be complied with for personnel working on this project.

A copy of the Prevailing Wage Rates is available on-line at the Bureau of Labor and Industries website at:

<https://www.oregon.gov/boli/employers/Pages/prevailing-wage.aspx>

When a contractor or subcontractor is a party to a statewide collective bargaining agreement in effect with any labor organization, the rate of wages provided for in such agreement shall be considered to be the prevailing rate of wage to be paid to the workers on this project.

Date _____

Signature of Bidder _____

Title _____

Business Name _____

CERTIFICATION OF ASBESTOS ABATEMENT

FOR

Project Name: 2nd & Park Regional Storm Facility Rehab

The undersigned confirms that if asbestos abatement is required the abatement shall be done by Department of Environmental Quality licensed contractor (ORS 468A.720) and the abatement shall be performed in conformity with DEQ and OSHA regulations and other standards related to workplace safety.

Date: _____

Signature of Bidder: _____

Title: _____

Business Name: _____

**CERTIFICATION OF NON-DISCRIMINATION
[ORS 279A.110(4) & OAR 137-049-0440(3)]**

FOR

Project Name: 2nd & Park Regional Storm Facility Rehab

The undersigned certifies that it has not discriminated against minority, women or emerging small business enterprises in the obtaining of subcontracts for this project and shall not discriminate against minority, women or emerging small business enterprises in awarding of subcontracts for this project.

Date _____

Signature of Bidder _____

Title _____

Business Name _____

CUSTOMER SERVICE ACKNOWLEDGMENT

FOR

Project Name: 2nd & Park Regional Storm Facility Rehab

Bid Closing: Date: _____ Time: _____ AM__ PM__

Note: This form is part of the inquiry concerning bidder responsibility and must be submitted with the other proposal forms as specified in Section 00120.40(h) of Division Four – Special Provisions.”

Bidder, by his/her signature below, hereby signifies that s/he has read and understands the construction specifications, including but not limited to the following sections of Division Four – Special Provisions, relating to customer service. These sections include, but are not limited to, the sections listed below:

- Section 00160, Source of Materials
- Section 00180.40, Limitation of Operations
- Section 00225, Work Zone Traffic Control

Bidder further acknowledges that s/he understands their terms, fully acknowledges their importance to successful completion of the project, and agrees to be bound thereby if awarded this contract. Bidder further assures the City that, if awarded this contract, s/he will promptly, efficiently and courteously carry out his/her responsibilities under the aforementioned specifications.

Signature of Bidder

Title

Name of Firm

Date

PREQUALIFICATION ACKNOWLEDGMENT

FOR

Project Name: 2nd & Park Regional Storm Facility Rehab

The undersigned confirms that the Bidder has complied with pre-qualification conditions in accordance with the laws of the State of Oregon (ORS 279C.430) by submitting proof of pre-qualification acceptance two (2) days prior to the Bid Opening date by submitting pre-qualification acceptance by either the State of Oregon Department of Transportation (ODOT), Washington County Department of Transportation, or any local major municipality.

Date: _____

Signature of Bidder: _____

Title: _____

Business Name: _____

BIDDER RESPONSIBILITY FORM

FOR

Project Name: 2nd & Park Regional Storm Facility Rehab

All information shall be typed or printed legibly

Note: Information provided in this form is part of the inquiry concerning bidder responsibility, and this form must be submitted with the other proposal forms as specified in Section 00120.40(g) of DIVISION FOUR - SPECIAL PROVISIONS."

Part A

Submitted by: _____
Signature Date

Name (print): _____

Name of Firm: _____

Address: _____

Phone: _____

Fax: _____

1. How many years has your organization done business as a General Contractor under the present business name? _____
2. How many years under (a) different name(s)? _____
3. List different names, if any, and dates of operation: _____

4. How many years has your organization been in business under its present business name? _____
5. How many years under (a) different name(s)? _____
6. List different names, if any, and dates of operation: _____

Part B – Complete the appropriate Portion Below

1. Bidder is an **INDIVIDUAL**:

Name of individual: _____

Doing Business as: _____

2. Bidder is a **CORPORATION**:

Name of Corporation as registered with the state of Oregon: _____

Date of Incorporation: _____ State of Incorporation: _____

Name of President: _____

Name of Secretary: _____

Name of Treasurer: _____

Name of Manager: _____

3. Bidder is a **LIMITED PARTNERSHIP**:

Name of Limited Partnership as registered with the state of Oregon: _____

Name of persons or parties composing the Limited Partnership (indicate whether an individual or corporation): _____

4. Bidder is a **GENERAL PARTNERSHIP**:

Name of General Partnership as registered with the state of Oregon: _____

Name of persons or parties composing the General Partnership (indicate whether an individual or corporation): _____

5. Bidder is a **JOINT VENTURE**:

Name of Joint Venture as registered with the state of Oregon: _____

Name of persons or parties composing the Joint Venture (indicate whether an individual or corporation): _____

Part C

1. What percent of the work do you normally perform with you own forces?

List Trades directly employed by you:

2. List the Construction Equipment you own or lease long-term:

3. Have you ever failed to complete any work awarded to you? _____
(Answer yes or no)

If so, indicate when, where, and why. _____

4. A. Have you ever defaulted on a contract? _____
(Answer yes or no)

If so, indicate when, where, and why.

B. What result: Lawsuit? Judgment? Arbitration? Settled? Other? (Circle the one that most applies)
If other, explain: _____

C. Are there currently any unpaid judgments against the business or any of its principals?
_____ (Answer yes or no)

If so, describe: _____

5. Has any Officer or Partner of your organization ever been an Officer or Partner of another
Organization that failed to complete a construction contract? _____ (Answer yes or no)

If so, describe circumstances below: _____

6. List major construction projects your organization currently has under contract as the general
contractor: _____

Project name: _____

City / Contact Name & phone #: _____

Architect/Engineer: _____

Contract Amount / Contract Date: _____

% Complete / Schedule Complete: _____

Project name: _____

City / Contact Name & phone #: _____

Architect/Engineer: _____

Contract Amount / Contract Date: _____

% Complete / Schedule Complete: _____

Project name: _____

City / Contact Name & phone #: _____

Architect/Engineer: _____

Contract Amount / Contract Date: _____

% Complete / Schedule Complete: _____

Add additional sheets listing projects as required

7. List major construction projects, similar to the one being bid, that your organization completed in the past 5 years as the general contractor if not shown on the State of Oregon Department of Administrative Services' Contractor's Prequalification Application:

Project name: _____

City / Contact Name & phone #: _____

Architect/Engineer: _____

Contract Amount / Contract Date: _____

Percent Completed with own forces: _____

Project name: _____

City / Contact Name & phone #: _____

Architect/Engineer: _____

Contract Amount / Contract Date: _____

Percent Completed with own forces: _____

Project name: _____

City / Contact Name & phone #: _____

Architect/Engineer: _____

Contract Amount / Contract Date: _____

Percent Completed with own forces: _____

Add additional sheets listing projects as required

8. List the construction experience of the principal individuals in your Organization; which ones will be assigned to this project (including the percentage of their time to be assigned to this project):

Individual's Name: _____

Construction experience - years: _____

Present position & years with organization: _____

Percentage of individual's time to be assigned to project: _____

Individual's Name: _____

Construction experience - years: _____

Present position & years with organization: _____

Percentage of individual's time to be assigned to project: _____

Individual's Name: _____

Construction experience - years: _____

Present position & years with organization: _____

Percentage of individual's time to be assigned to project: _____

- A. Have any of the principal individuals in your organization been convicted under state or federal statutes of embezzlement, theft, forgery, bribery, falsification or destruction of records, or receiving stolen property? _____ (Answer yes or no). If so, describe circumstances below:

- B. Have any of the principal individuals in your organization been the subject to a civil judgment for fraud? _____ (Answer yes or no). If so, describe circumstances below:

9. Bank References:

| | | |
|-------|-------|-------|
| _____ | _____ | _____ |
| _____ | _____ | _____ |
| _____ | _____ | _____ |

10. Trade References:

| | | |
|-------|-------|-------|
| _____ | _____ | _____ |
| _____ | _____ | _____ |
| _____ | _____ | _____ |

11. List names of Bonding and Insurance Companies, name and address of agents, and maximum bonding capacity. What portion remains on this Bonding Capacity at the time of submittal of the Bid? _____

12. The bidder agrees to furnish, upon request by the City, within 5-days after the Bid Opening, a current Statement of Financial Conditions, including Contractor's latest regular dated financial statement or balance sheet which must contain the following items:

- Current assets: (cash, joint venture accounts, accounts receivable, notes receivable, accrued interest on notes, deposits, and materials and prepaid expenses), net fixed assets and other assets.
- Current liabilities: (Accounts payable, notes payable, accrued interest on notes, provisions for income taxes, advances received from owners, accrued salaries accrued payroll taxes), other liabilities, and capital (capital stock, authorized and outstanding shares per values, earned surplus).

Date of statement or balance sheet: _____

Name of firm preparing statement: _____

By: _____

Bidder's Initials: _____

Bid Closing: Date: _____ **Time:** _____ **AM** ____ **PM** ____



2nd & Park Regional Storm Facility Rehab

DATE

ADDENDUM NO. 1

Addition/Change to the Contract Documents

The work provided for in this addendum shall become a part of the drawings and specifications for this project.

- 1.
- 2.

This ADDENDUM shall be signed and attached to the Bidder's Proposal and shall subsequently become part of the Contract Documents.

| | |
|----------------------|--|
| Company Name | |
| | |
| Contractor Name | |
| | |
| Contractor Signature | |
| | |
| Date | |

Division Two
Contract Forms

STANDARD CONTRACT PROVISIONS

(These provisions not to be altered without approval of the City Attorney.)

1. Access to Records

The Contractor shall maintain, and the City of Sherwood ("City") and its duly authorized representatives shall have access during normal business hours to the books, documents, papers, and records of the Contractor which are directly pertinent to the specific Contract for the purpose of making audit, examination, excerpts, and transcripts for a period of three years after final payment. Copies of applicable records shall be made available upon reasonable request. Payment for cost of copies is reimbursable by the City.

2. Audits

- (a) The City, either directly or through a designated representative, at City's expense except as provided in subsection 2(b), may conduct financial and performance audits of the billings and services specified in this Contract at any time in the course of the Contract and during the three (3) year period established by section 1, **Access to Records**. Audits will be conducted in accordance with generally accepted auditing standards as promulgated in Government Auditing Standards by the Comptroller General of the United States General Accounting Office.
- (b) If an audit discloses that payments to the Contractor were in excess of the amount to which the Contractor was entitled, then the Contractor shall repay the amount of the excess to the City. If the payments to the Contractor were in excess of the amount to which the Contractor was entitled by five percent (5%) or more, then Contractor shall additionally repay to the City the reasonable costs of the audit performed under subsection 2(a).
- (c) If any audit shows performance of services is not efficient in accordance with Government Auditing Standards, or that the program is not effective in accordance with Government Auditing Standards, the City may pursue remedies provided under section 5, **Early Termination of Contract** and section 7, **Remedies**.

3. Effective Date and Duration

The passage of the Contract expiration date, or early termination of this Contract, shall not extinguish, prejudice, or limit either party's right to enforce this Contract with respect to any default or defect in performance that has not been cured.

4. Payments

City agrees to pay Contractor based on the fee schedule in Exhibit B, attached hereto and incorporated herein by reference, in a total sum not to exceed the amount indicated on the cover page of this Contract, for the scope of work identified in Exhibit A, attached hereto and incorporated herein by reference. Contractor shall submit detailed written invoices to City for work performed, referencing the work performed and the fee schedule in Exhibit B, at a frequency not to exceed one invoice per calendar month, and no later than sixty (60) calendar days after performance of the work referenced in the invoice. Within thirty (30) calendar days of receipt of each invoice, City shall submit payment to Contractor or shall notify Contractor in writing of any dispute with regard to such invoice.

5. Early Termination of Contract

- (a) The City and the Contractor, by mutual written agreement, may terminate this Contract at any time.
- (b) The City, by written notice to the Contractor, may terminate this Contract for any reason deemed appropriate in its sole discretion, such termination to be effective thirty (30) calendar days after the effective date of such notice or at such later date as specified in such notice.
- (c) City may terminate this Contract by written notice to Contractor, such termination to be effective immediately upon the effective date of such notice or at such later date as specified in such notice, upon the occurrence of any of the following events:
 - (1) City fails to receive funding, or appropriations, limitations, or other expenditure authority at levels sufficient to pay for Contractor's work;
 - (2) Federal or state laws, regulations, or guidelines are modified or interpreted in such a way that either the work under this Contract is prohibited or City is prohibited from paying for such work from the planned funding source;
 - (3) Contractor no longer holds any license or certificate that is required to perform the work, or any license or certificate required by statute, rule, regulation, or other law to be held by the Contractor to provide the services required by this Contract is for any reason denied, revoked, suspended, not renewed, or changed in such a way that Contractor no longer meets requirements for such license or certificate.
 - (4) City determines, in its sole discretion, that Contractor has violated section 25, **Information Technology**.
- (d) Either the City or the Contractor may terminate this Contract in the event of a breach of the Contract by the other. Prior to such termination, however, the party seeking the termination shall give to the other party written notice of the breach and of the party's intent to terminate. If the party has not entirely cured the breach within fifteen (15) calendar days of the notice, then the party giving the notice may terminate the Contract at any time thereafter by giving a written notice of termination.
- (e) Upon receiving a written notice of termination of this Contract, Contractor shall immediately cease all activities under this Contract, unless City expressly directs otherwise in such notice. Upon termination of this Contract, Contractor shall deliver to City all documents, information, works in progress, and other property that are or would be deliverables had the Contract been completed.

6. Payment on Early Termination

- (a) In the event of termination under subsection 5(a) or 5(b), **Early Termination of Contract** hereof, the City shall pay the Contractor for work performed in accordance with the Contract prior to the termination date.
- (b) In the event of termination under subsection 5(d), **Early Termination of Contract** hereof, by the Contractor due to a breach by the City, the City shall pay the Contractor as provided in subsection (a) of this section.
- (c) In the event of termination under subsection 5(d), **Early Termination of Contract** hereof, by the City due to a breach by the Contractor, the City shall pay the Contractor as provided in subsection (a) of this section, subject to set off of excess costs, as provided for in section 7(a), **Remedies**.
- (d) In the event of early termination, all of the Contractor's work product will become and remain property of the City.

7. Remedies

- (a) In the event of termination under subsection 5(d), **Early Termination of Contract**, hereof, by the City due to a breach by the Contractor, the City may complete the work itself, by contract with another contractor, or by a combination thereof. In the event the cost of completing the work exceeds the remaining unpaid balance of the total compensation provided under this Contract, then the Contractor shall pay to the City the amount of the excess.
- (b) The remedies provided to the City under section 5, **Early Termination of Contract** and section 7, **Remedies** for a breach by the Contractor shall not be exclusive. The City also shall be entitled to any other equitable and legal remedies that are available.
- (c) In the event of breach of this Contract by the City, the Contractor's remedy shall be limited to termination of the Contract and receipt of payment as provided in section 5(d), **Early Termination of Contract** and section 6(b), **Payment on Early Termination** hereof.

8. Subcontracts and Assignment

Contractor shall not subcontract, assign or transfer any of the work scheduled under this Contract, without the prior written consent of the City. Notwithstanding City approval of a sub-contractor, the Contractor shall remain obligated for full performance hereunder, and the City shall incur no obligation other than its obligations to the Contractor hereunder. The Contractor agrees that if sub-contractors are employed in the performance of this Contract, the Contractor and its sub-contractors are subject to the requirements and sanctions of ORS Chapter 656, Workers' Compensation. Contractor further agrees that Contractor will be solely responsible for ensuring any sub-contractors fully comply with the terms of this Contract, and that Contractor will be solely liable for actions or omissions of sub-contractors under this Contract. City reserves the right to review the subcontractors proposed, and the Contractor shall not retain a subcontractor to which City has a reasonable objection.

9. Compliance with Applicable Law

In connection with its activities under this Contract, Contractor shall use the standard of care in its profession to comply with all applicable federal, state and local laws and regulations.

10. Indemnity - Standard of Care

If Contractor's services involve engineering or planning consulting, the standard of care applicable to Contractor's service will be the degree of skill and diligence normally employed by professional engineers or planning contractors performing the same or similar services at the time such services are performed. Contractor will re-perform any services not meeting this standard without additional compensation. City has relied upon the professional ability and training of Contractor as a material inducement to enter into this Contract. Contractor represents that all of its work will be performed in accordance with generally accepted professional practices and standards as well as the requirements of applicable federal, state, and local laws, it being understood that acceptance of Contractor's work by City will not operate as a waiver or release.

Contractor acknowledges responsibility for liability arising out of the performance of this Contract and shall defend, indemnify, and hold harmless City and its officers, agents, volunteers, and employees against any and all liability, settlements, loss, damage, costs, and expenses (including attorney's fees and witness costs at both trial and on appeal, whether or not a trial or appeal ever takes place, including any hearing before federal or state administrative agencies) arising from or in connection with any action, suit, demand, or claim resulting or allegedly resulting from, attributable in whole or in part to, or in any way connected with Contractor's and Contractor's officers', agents', volunteers', and employees' acts, omissions, activities, or services in the course of performing this Contract, to the fullest extent permitted by law, and except to the extent otherwise void or unenforceable under ORS 30.140. Contractor's activities are deemed to include those of subcontractors. The City may, at any time at its election assume its own defense and settlement in the event that it determines that Contractor is not adequately defending the City's interests, or that an important governmental principle is at issue, or that it is in the best interests of the City to do so. If any aspect of this indemnity is found to be illegal or invalid for any reason whatsoever, such illegality or invalidity does not affect the validity of the remainder of this indemnification.

This section will survive the termination or revocation of this Contract, regardless of cause.

11. Insurance

Contractor shall obtain at its expense, and maintain for the term of this contract, occurrence form commercial general liability, professional liability, and commercial automobile liability insurance, including coverage for all owned, hired, and non-owned automobiles, for the protection of Contractor, the City, its Councilors, officers, agents, volunteers, and employees. Such coverage shall be primary and non-contributory. Coverage shall include personal injury, bodily injury, including death, and broad form property damage, including loss of use of property, occurring in the course of or in any way related to Contractor's operations, in an amount not less than \$2,000,000 combined single limit per occurrence and \$2,000,000 aggregate. Such

insurance shall name the City as an additional insured. Contractor, its subcontractors, if any, and all employers providing work, labor, or materials under this Contract, who are subject employers under the Oregon Workers' Compensation Law, shall comply with ORS 656.017, which requires them to provide workers compensation coverage that satisfies Oregon law for all their subject workers. Out-of-state employers must provide workers' compensation coverage for their workers that complies with ORS 656.126. This insurance shall include the City, the Contractor, and its sub-contractors as their interests may appear. All policies will provide for not less than thirty (30) calendar days' written notice to the City before they may be canceled. Prior to commencing work under this Contract, and thereafter upon request, Contractor shall furnish the City certificates of insurance and necessary endorsements evidencing the effective dates, amounts, and types of insurance required by this Contract.

12. Ownership of Work Product

All work products of the Contractor, which result from this Contract, are the exclusive property of the City; provided, that Contractor is hereby granted an irrevocable, royalty free, worldwide, perpetual license to use, reproduce, copy, distribute and make derivatives of its work product, regardless of whether Contractor has resigned, this Contract has been terminated, Contractor's scope of services has been modified, or Contractor's services under this Contract have been completed.

13. Nondiscrimination

Contractor agrees to comply with all applicable requirements of federal and state civil rights and rehabilitation statutes, rules, and regulations. Contractor also shall comply with the Americans With Disabilities Act of 1990 (Pub L. No. 101-336) including Title II of that Act, ORS 659A.142, and all regulations and administrative rules established pursuant to those laws.

14. Successors in Interest

The provisions of this Contract shall be binding upon and shall inure to the benefit of the parties hereto, and their respective successors and approved assigns.

15. Severability

The parties agree that if any term or provision of this Contract is declared by a court of competent jurisdiction to be illegal or in conflict with any law, the validity of the remaining terms and provisions shall not be affected, and the rights and obligations of the parties shall be construed and enforced as if the Contract did not contain the particular term or provision held to be invalid.

16. Waiver

The failure of the City to enforce any provision of this Contract shall not constitute a waiver by the City of that or any other provision.

17. Errors

The Contractor shall perform such additional work as may be necessary to correct errors in the work required under this Contract without undue delays and without additional cost.

18. Governing Law; Forum

The provisions of this Contract shall be construed in accordance with the provisions of the laws of the State of Oregon, without regard to conflicts of law principles. Any action or suits involving any question arising under this Contract must be brought in the appropriate court in Washington County, Oregon or, only if there is no Oregon state court jurisdiction, the United States District Court for the District of Oregon, and each party hereby submits to the exclusive jurisdiction of those courts for purposes of any such proceeding. Any trial will be to the court without a jury.

19. Amendments

The City and the Contractor may amend this Contract at any time only by written amendment executed by the City and the Contractor.

20. License

Prior to beginning work under this Contract, the Contractor shall provide a Construction Contractor's Board (CCB) license number in the space provided on page one of this Contract.

21. Payment to Vendors and Sub-contractors

Contractor must promptly pay any persons supplying services, material, or equipment to Contractor in its performance of the work under this Contract. The Contractor shall not take or fail to take any action in a manner that causes the City or any materials that the Contractor provides hereunder to be subject to any claim or lien of any person without the City's prior written consent.

22. Exhibits

Each document that is attached to this Contract as an Exhibit shall be labeled with an Exhibit letter and listed below. Provisions and covenants contained in Exhibits are hereby incorporated by reference and shall become a part of this Contract as if fully set forth herein. If any item in an Exhibit contradicts this Contract, this Contract shall take precedence over the conflicting item in the Exhibit.

List of Exhibits

- Exhibit A – Scope of Work/Contract Drawings
- Exhibit B – Fee Schedule

23. Merger Clause

This Contract and attached exhibits constitutes the entire agreement between the parties. No waiver, consent, modification, or change of terms of this Contract shall bind either party unless in writing and signed by both parties. Such waiver, consent, modification, or change, if made, shall be effective only in specific instances and for the specific purpose given. There are no understandings, agreements, or representations, oral or written, not specified herein regarding this Contract. Contractor, by the signature of its authorized representative, hereby acknowledges that he or she has read this Contract, understands it and agrees to be bound by its terms and conditions.

24. Mediation

- (a) Should any dispute arise between the parties to this Contract it is agreed that such dispute will be submitted to a mediator prior to any litigation and the parties hereby expressly agree that no claim or dispute arising under the terms of this Contract shall be resolved other than first through mediation and only in the event said mediation efforts fail, through litigation.
- (b) The parties shall exercise good faith efforts to select a mediator who shall be compensated equally by both parties. Mediation will be conducted in Portland, Oregon, unless both parties agree in writing otherwise. Both parties agree to exercise good faith efforts to resolve disputes covered by this section through this mediation process. If a party requests mediation and the other party fails to respond within ten (10) calendar days, or if the parties fail to agree on a mediator within ten (10) calendar days, a mediator shall be appointed by the presiding judge of the Washington County Circuit Court upon the request of either party. The parties shall have any rights at law or in equity with respect to any dispute not covered by this Section.

25. Information Technology

If Contractor access to City's information technology systems is necessary for the performance of this Contract:

- (a) Contractor agrees to sign and be bound by the terms of the City's then-current Contractor Security Policy, as it may be amended by City from time to time during the course of this Contract.
- (b) Contractor shall use the standard of care in its profession to safeguard any and all usernames, passwords, and other confidential information relating to accessing said systems; will limit access to such information to the smallest number of Contractor's employees and/or subcontractors as is reasonably practical; and will provide City with the names of all such employees and/or subcontractors who will be provided such information;
- (c) Contractor will not attempt to access any City information technology resources beyond those necessary for performance of this Contract; and
- (d) Contractor will be solely liable for any damages to City's information technology systems, data breaches, and any other losses or damages relating to Contractor's access to City's information technology systems.

26. Notice

Any notice required to be provided to City under this Contract shall be provided to the City Project Manager specified on the cover page of this Contract at the address for the City specified on the cover page of this Contract. Any notices required to be provided to Contractor under this Contract shall be provided to the Contractor Contact specified on the cover page of this Contract at the address for the Contractor specified on the cover page of this Contract. Notices shall be made by personal service, in which case they are effective on the date of service, or by certified mail, in which case they are effective on the date of delivery, or if delivery is refused, upon the date of delivery refusal. Either party may alter the person designated for receipt of notices under this Contract by written notice to the other party.

27. Miscellaneous Terms

- (a) Contractor Identification. Contractor shall furnish Contractor's employer identification number to City, as designated by the Internal Revenue Service, or, if the Internal Revenue Service has designated no employer identification number, Contractor's Social Security number.
- (b) Duty to Inform. Contractor shall give prompt written notice to City if, at any time during the performance of this Contract, Contractor becomes aware of actual or potential problems, faults, or defects in the project, any nonconformance with the Contract, or with any federal, state, or local law, rule, or regulation, or has any objection to any decision or order made by City. Any delay or failure on the part of City to provide a written response to Contractor shall constitute neither agreement with nor acquiescence in Contractor's statement or claim, and shall not constitute a waiver of any of City's rights.
- (c) Independent Contractor. Contractor is an independent contractor for all purposes and shall be entitled to no compensation other than the compensation expressly provided by this Contract.
- (d) Time is of the Essence. Time is of the essence under this Contract.
- (e) Authority. The parties signing this Contract are authorized to sign and to bind their respective contracting parties to the terms of the Contract.
- (f) Conflict of Interest. Except with City's prior written consent, Contractor shall not engage in any activity, or accept any employment, interest or contribution that would, or would reasonably appear, to compromise Contractor's professional judgment with respect to this Contract, including, without limitation, concurrent employment on any project in direct competition with the subject of this Contract.
- (g) No Third-Party Beneficiaries. City and Contractor are the only parties to this Contract and are the only parties entitled to enforce its terms. Nothing in this Contract gives, is intended to give, or shall be construed to give or provide, any benefit or right, whether directly or indirectly or otherwise, to third persons unless such third persons are individually identified by name herein and expressly described as intended beneficiaries of the terms of this Contract.

28. Statutory Provisions

- (a) As provided by ORS 279C.505, Contractor shall:
- (1) Make payment promptly, as due, to all persons supplying to Contractor labor or material for the performance of the work provided for in this Contract.
 - (2) Pay all contributions or amounts due the Industrial Accident Fund from the Contractor or subcontractor incurred in the performance of this Contract.
 - (3) Not permit any lien or claim to be filed or prosecuted against the state or a county, school district, municipality, municipal corporation or subdivision thereof, on account of any labor or material furnished.
 - (4) Pay to the Department of Revenue all sums withheld from employees under ORS 316.167.
 - (5) Demonstrate that an employee drug testing program is in place.
- (b) As provided by ORS 279C.530, Contractor shall promptly, as due, make payment to any person, co-partnership, association, or corporation furnishing medical, surgical, and hospital care services or other needed care and attention, incident to sickness or injury, to the employees of Contractor, of all sums that Contractor agrees to pay for the services and all moneys and sums that Contractor collected or deducted from the wages of employees under any law, contract, or agreement for the purpose of providing or paying for the services. It is a condition of this Contract that all employers working under this Contract are either subject employers that will comply with ORS 656.017 or employers that are exempt under ORS 656.126.
- (c) As provided by ORS 279A.110, Contractor may not discriminate against a subcontractor in the awarding of a subcontract because the subcontractor is a minority, women, or an emerging small business enterprise certified under ORS 200.055 or a business enterprise that is owned or controlled by or that employs a disabled veteran, as defined in ORS 408.225. If Contractor violates this subsection, City may regard the violation as a breach of contract that permits the City to: (1) terminate this Contract; or (2) exercise any remedies for breach of contract that are reserved in this Contract.
- (d) As provided by ORS 279C.520:
- i. A person may not be employed for more than ten (10) hours in any one day, or forty (40) hours in any one week, except in cases of necessity, emergency, or when the public policy absolutely requires it, and in such cases, except in cases of contracts for personal services designated under ORS 279C.100, the employee shall be paid at least time and a half pay:
 - (1) For all overtime in excess of eight (8) hours in any one day or forty (40) hours in any one week when the work week is five (5) consecutive days, Monday through Friday; or
 - (2) For all overtime in excess of ten (10) hours in any one day or forty (40) hours in any one week when the work week is four (4) consecutive days, Monday through Friday; and
 - (3) For all work performed on Saturday and on any legal holiday specified in ORS 279C.540.
 - ii. Contractor must give notice in writing to employees who work on this Contract, either at the time of hire or before commencement of work on this Contract, or by posting a notice in a location frequented by employees, of the number of hours per day and days per week that the employees may be required to work.
 - iii. Contractor must comply with ORS 652.220 and shall not unlawfully discriminate against any of Contractor's employees in the payment of wages or other compensation for work of comparable character on the basis of an employee's membership in a protected class. Contractor's compliance with this section constitutes a material element of this Contract and a failure to comply constitutes a breach that entitles City to terminate this Contract for cause.
 - iv. Contractor may not prohibit any of Contractor's employees from discussing the employee's rate of wage, salary, benefits, or other compensation with another employee or another person. Contractor may not retaliate against an employee who discusses the employee's rate of wage, salary, benefits, or other compensation with another employee or another person.
- (e) Contractor must give notice in writing to employees who work on this Contract, either at the time of hire or before commencement of work on this Contract, or by posting a notice in a location frequented by employees, of the number of hours per day and days per week that the employees may be required to work.
- (f) As provided by ORS 279C.510, if this is:
- (1) A contract for demolition, the Contractor shall salvage or recycle construction and demolition debris, if feasible and cost-effective.
 - (2) A contract for lawn and landscape maintenance, the Contractor shall compost or mulch yard waste material at an approved site, if feasible and cost-effective.
- (g) As provided by ORS 279C.515:
- (1) If the Contractor fails, neglects or refuses to pay promptly a person's claim for labor or services that the person provides to the Contractor or a subcontractor in connection with this Contract as the claim becomes due, the City may pay the amount of the claim to the person that provides the labor or services and charge the amount of the payment against funds due or to become due the Contractor by reason of this Contract.
 - (2) If the Contractor or a first-tier subcontractor fails, neglects or refuses to pay a person that provides labor or materials in connection with this Contract within thirty (30) days after receiving payment from the City or the Contractor, the Contractor or first-tier subcontractor owes the person the amount due plus interest charges that begin at the end of the ten (10) day period within which payment is due under ORS 279C.580(4) and that end upon final payment, unless payment is subject to a good faith dispute as defined in ORS 279C.580. The rate of interest on the amount due is nine percent per annum. The amount of interest may not be waived.
 - (3) If the Contractor or a subcontractor fails, neglects or refuses to pay a person that provides labor or materials in connection with this Contract, the person may file a complaint with the Construction Contractors Board, unless payment is subject to a good faith dispute as defined in ORS 279C.580.
 - (4) Paying a claim in the manner authorized in this section does not relieve the Contractor or the Contractor's surety from obligation with respect to an unpaid claim.

- (h) As provided by ORS 279C.580, Contractor shall include in each subcontract for property or services Contractor enters into with a first-tier subcontractor, including a material supplier, for the purpose of performing a construction contract:
- (1) A payment clause that obligates Contractor to pay the first-tier subcontractor for satisfactory performance under the subcontract within ten (10) days out of amounts the City pays to Contractor under this contract.
 - (2) A clause that requires Contractor to provide a first-tier subcontractor with a standard form that the first-tier subcontractor may use as an application for payment or as another method by which the subcontractor may claim a payment due from Contractor.
 - (3) A clause that requires Contractor, except as otherwise provided in this paragraph, to use the same form and regular administrative procedures for processing payments during the entire term of the subcontract. Contractor may change the form or the regular administrative procedures Contractor uses for processing payments if Contractor:
 - a. Notifies the subcontractor in writing at least 45 days before the date on which Contractor makes the change; and
 - b. Includes with the written notice a copy of the new or changed form or a description of the new or changed procedure.
 - (4) An interest penalty clause that obligates Contractor, if Contractor does not pay the first-tier subcontractor within thirty (30) days after receiving payment from the City, to pay the first-tier subcontractor an interest penalty on amounts due in each payment Contractor does not make in accordance with the payment clause included in the subcontract under paragraph (a) of this subsection. Contractor or a first-tier subcontractor is not obligated to pay an interest penalty if the only reason that Contractor or a first-tier subcontractor did not make payment when payment was due is that Contractor or a first-tier subcontractor did not receive payment from the City or Contractor when payment was due. The interest penalty:
 - a. Applies to the period that begins on the day after the required payment date and that ends on the date on which the amount due is paid; and
 - b. Is computed at the rate specified in ORS 279C.515(2).Additionally, Contractor, in each of Contractor's subcontracts, shall require the first-tier subcontractor to include a payment clause and an interest penalty clause that conforms to the standards set forth above in each of the first-tier subcontractor's subcontracts and shall require each of the first-tier subcontractor's subcontractors to include such clauses in the first-tier subcontractor's subcontracts with each lower-tier subcontractor or supplier.
- (i) Construction Contractors Board (CCB) requirements: Contractor must have a payment bond filed with CCB when required by ORS 279C.380 and 279C.390. Contractor and each subcontractor must have a public works bond filed with CCB before starting work under this Contract, unless exempt under state law.

[SIGNATURES ON COVER PAGE TO CONTRACT]

PERFORMANCE BOND

Bond No. _____

Project Name: **2nd & Park Regional Storm Facility Rehab**

| | |
|------------------------------|-----------------------------------|
| _____ (Surety #1) | Bond Amount No. 1: \$ _____ |
| _____ (Surety #2)* | Bond Amount No. 2:* \$ _____ |
| * If using multiple sureties | Total Penal Sum of Bond: \$ _____ |

We, _____ as Principal, and the above identified Surety(ies), authorized to transact surety business in Oregon, as Surety, hereby jointly and severally bind ourselves, our respective heirs, executors, administrators, successors and assigns firmly by these presents to pay unto the City of Sherwood the sum of (Total Penal Sum of Bond)

(Provided, that we the Sureties bind ourselves in such sum “jointly and severally” as well as “severally” only for the purpose of allowing a joint action or actions against any or all of us, and for all other purposes each Surety binds itself, jointly and severally with the Principal, for the payment of such sum only as is set forth opposite the name of such Surety), and

WHEREAS, the Principal has entered into a contract with the City of Sherwood, the Plans, Specifications, terms and conditions of which are contained in the above-referenced Solicitation;

WHEREAS, the terms and conditions of the contract, together with applicable Plans, Standard specifications and Standard Drawings, Supplemental Specifications and Special Provisions, Addenda, Bid Schedule, Prevailing Wage Rates are made a part of this Performance Bond by reference, whether or not attached to the contract (all hereafter called “Contract”); and

WHEREAS, the Principal has agreed to perform the Contract in accordance with the terms, conditions, requirements, Plans and Specifications, and all authorized modifications of the Contract which increase the amount of the Work, the amount of the Contract, or constitute an authorized extension of the time for performance, notice of any such modifications hereby being waived by the Surety;

NOW, THEREFORE, THE CONDITION OF THIS BOND IS SUCH that if the Principal herein shall faithfully and truly observe and comply with the terms, conditions and provisions of the Contract, in all respects, and shall well and truly and fully do and perform all matters and things undertaken by Contractor to be performed under the Contract, upon the terms set forth therein, and within the time prescribed therein, or as extended as provided in the Contract, with or without notice to the Sureties, and shall indemnify and save harmless the City of Sherwood, and the _____ (name of institution and any other Owner agency), and members thereof, its officers, employees and agents, against any direct or indirect damages or claim of every kind and description that shall be suffered or claimed to be suffered in connection with or arising out of the performance of the Contract by the Principal or its subcontractors, and shall in all respects perform said contract according to law, then this obligation is to be void; otherwise, it shall remain in full force and effect.

Nonpayment of the bond premium will not invalidate this bond nor shall the City of Sherwood, or the above-referenced agency(ies), be obligated for the payment of any premiums.

This bond is given and received under authority of ORS Chapter 279C, the provisions of which hereby are incorporated into this bond and made a part hereof.

IN WITNESS WHEREOF, WE HAVE CAUSED THIS INSTRUMENT TO BE EXECUTED AND SEALED BY OUR DULY AUTHORIZED LEGAL REPRESENTATIVES.

Dated this _____ day of _____, 20__.

PRINCIPAL: _____

By _____
Signature

Official Capacity

Attest: _____
Corporation Secretary

SURETY: _____

[Add signatures for each surety if using multiple bonds]

BY ATTORNEY-IN-FACT:

[Power-of-Attorney must accompany each surety bond]

Name

Signature

Address

City State Zip

Phone Fax Email

PAYMENT BOND

Bond No. _____
Solicitation _____
Project Name **2nd & Park Regional Storm Facility Rehab**

_____ (Surety #1) Bond Amount No. 1: \$ _____
_____ (Surety #2)* Bond Amount No. 2:* \$ _____
* If using multiple sureties Total Penal Sum of Bond:\$ _____

KNOW ALL MEN BY THESE PRESENTS: That, WHEREAS, the City of Sherwood, on _____, has awarded to _____, hereinafter designated as "Principal", a Contract for construction of the 2nd & Park Regional Storm Facility Rehab, the terms and provisions of which contract are incorporated herein by reference, and;

WHEREAS, said Principal is required to furnish a bond in connection with this said Contract, providing that if said Principal, or any of his or its subcontractors, shall fail to pay for any materials, provisions, provender or other supplies or teams used in, upon, for, or about the performance of the work contracted to be done, or any other work or labor done thereon of any kind, the Surety of this body will pay the same to extend hereinafter set forth;

NOW, THEREFORE, we the Principal and _____, as Surety, are held and firmly bound unto the City of Sherwood, in the penal sum of _____ Dollars (\$ _____), lawful money of the United States, being one hundred percent (100%) of the Contract amount for the payment of which sum well and truly to be made, we bond ourselves, our heirs, executors, administrators and successors, jointly and severally, firmly by these presents.

NOW, THEREFORE, if the above bounden Principal or any of his subcontractor shall promptly make payment to all persons supplying labor and material or amounts due in the prosecution of the work provided for in said Contract, and any and all duly authorized modifications of said Contract that may hereafter be made, then this obligation shall be void; otherwise, this obligation shall remain in full force and virtue; and if the bounden Principal or any of his subcontractors fails to promptly pay any of the persons or amounts due with respect to work or labor performed by any such claimant, the Surety will pay for the same, in an amount not exceeding the sum specified in this bond, and also in case suit brought upon this bond, a reasonable attorney's fee, be fixed by the court; and this bond shall insure to the benefit of any persons so as to give a right of action to such persons or their assigns in any suit brought upon this bond.

The bond shall insure to the benefit of any all persons, companies and corporations entitle to file claims, so as to give a right of action to them or their assigns in any suit brought upon this bond.

And the said Surety, for value received, hereby stipulates and agrees that no change, extension of time, alteration or addition to the terms of the Contract, or to the work to be performed thereunder, or the Specifications accompanying the same shall in any wise affect its obligations on this bond; and it does hereby waive notice of any such change, extension of time, alteration or addition to the terms of the Contract, or to the work or to the Specifications.

Nonpayment of the bond premium will not invalidate this bond nor shall the City of Sherwood, or the above-referenced agency(ies), be obligated for the payment of any premiums.

This bond is given and received under authority of ORS Chapter 279C, the provisions of which hereby are incorporated into this bond and made a part hereof.

IN WITNESS WHEREOF, WE HAVE CAUSED THIS INSTRUMENT TO BE EXECUTED AND SEALED BY OUR DULY AUTHORIZED LEGAL REPRESENTATIVES:

Dated this _____ day of _____, 20__.

PRINCIPAL: _____

By _____
Signature

Official Capacity

Attest: _____
Corporation Secretary

SURETY: _____
[Add signatures for each if using multiple bonds]

BY ATTORNEY-IN-FACT:
[Power-of-Attorney must accompany each bond]

Name

Signature

Address

City State Zip

Phone Email



STATE OF OREGON STATUTORY PUBLIC WORKS BOND

Surety bond #: _____ CCB # (if applicable): _____
We, _____, as principal, and

_____, a corporation qualified and authorized to do business in the State of Oregon, as surety, are held and firmly bound unto the State of Oregon for the use and benefit of the Oregon Bureau of Labor and Industries (BOLI) in the sum of thirty thousand dollars (\$30,000) lawful money of the United States of America to be paid as provided in ORS chapter 279C, as amended by Oregon Laws 2005, chapter 360, for which payment well and truly to be made, we bind ourselves, our heirs, personal representatives, successors and assigns, jointly and severally, firmly by this agreement.

WHEREAS, the above-named principal wishes to be eligible to work on public works project(s) subject to the provisions of ORS chapter 279C, as amended by Oregon Laws 2005, chapter 360, and is, therefore, required to obtain and file a statutory public works bond in the penal sum of \$30,000 with good and sufficient surety as required pursuant to the provisions of section 2, chapter 360, Oregon Laws 2005, conditioned as herein set forth.

NOW, THEREFORE, the conditions of the foregoing obligations are that if said principal with regard to all work done by the principal as a contractor or subcontractor on public works project(s), shall pay all claims ordered by BOLI against the principal to workers performing labor upon public works projects for unpaid wages determined to be due, in accordance with ORS chapter 279C, as amended by Oregon Laws 2005, chapter 360, and OAR Chapter 839, then this obligation shall be void; otherwise to remain in full force and effect.

This bond is for the exclusive purpose of payment of wage claims ordered by BOLI to workers performing labor upon public works projects in accordance with ORS chapter 279C, as amended by Oregon Laws 2005, chapter 360.

This bond shall be one continuing obligation, and the liability of the surety for the aggregate of any and all claims which may arise hereunder shall in no event exceed the amount of the penalty of this bond.

This bond shall become effective on the date it is executed by both the principal and surety and shall continuously remain in effect until depleted by claims paid under ORS chapter 279C, as amended by Oregon Laws 2005, chapter 360, unless the surety sooner cancels the bond.

This bond may be cancelled by the surety and the surety be relieved of further liability for work performed on contracts entered after cancellation by giving 30 days' written notice to the principal, the Construction Contractors Board, and BOLI. Cancellation shall not limit the responsibility of the surety for the payment of claims ordered by BOLI relating to work performed during the work period of a contract entered into before cancellation of this bond.

IN WITNESS WHEREOF, the principal and surety execute this agreement. The surety fully authorizes its representatives in the State of Oregon to enter into this obligation.

SIGNED, SEALED AND DATED this _____ day of _____, 20 _____

Surety by:

Principal by:

Company Name (Seal)

Name

Signature

Signature

Title (e.g. Attorney-in-Fact)

Title

Address

City State Zip

**SEND BOND TO: Construction Contractors Board
PO Box 14140
Salem, OR 97309-5052
Telephone: (503) 378-4621**



Home of the Tualatin River National Wildlife Refuge

City of Sherwood
22560 SW Pine St.
Sherwood, OR 97140
Tel 503-625-5522
Fax 503-625-5524
www.sherwoodoregon.gov

Mayor
Tim Rosener

Council President
Kim Young

Councilors
Renee Brouse
Taylor Giles
Keith Mays
Doug Scott
Dan Standke

City Manager
Craig Sheldon

Assistant City Manager
Kristen Switzer

_____, 2026

Re: **Notice of Intent to Award**

2nd & Park Regional Storm Facility Rehab

Dear Proposer:

This is the Notice of Intent to Award required to be posted on the City's website pursuant to OAR 137-049-0395(1).

The City of Sherwood received ____ bids for work associated with the **2nd & Park Regional Storm Facility Rehab**. The bids were opened at the Sherwood City Hall on April 9, 2026 at 2:05 PM. The lowest responsive bidder was **XXXXXX** with a quote of **\$XX.XX**.

City staff will recommend award of the contract for the **2nd & Park Regional Storm Facility Rehab** to _____. If you wish to protest the City's Intent to Award, you must do so within seven (7) days after the date of the issuance of this notice. The protest must follow the process set forth in OAR 137-049-450(4). Any protest not so complying, will not be considered by the City. Protests must be directed to:

Sofi Lam, P.E.
City of Sherwood – Engineering Department
22560 SW Pine St
Sherwood, OR 97140

If you have any questions, please contact Sofi Lam, P.E. at (503) 925-2303 or lams@sherwoodoregon.gov



Home of the Tualatin River National Wildlife Refuge

City of Sherwood
22560 SW Pine St.
Sherwood, OR 97140
Tel 503-625-5522
Fax 503-625-5524
www.sherwoodoregon.gov

_____, 2026

XXX
XXX
XXX

Mayor
Tim Rosener

Council President
Kim Young

Councilors
Renee Brouse
Taylor Giles
Keith Mays
Doug Scott
Dan Standke

City Manager
Craig Sheldon

Assistant City Manager
Kristen Switzer

NOTICE OF AWARD

2nd & Park Regional Storm Facility Rehab

You are notified that your bid dated April 9, 2026 for the above stated project has been considered. You are the apparent low responsive bidder for the project and have been awarded the subject contract.

Attached are 3 copies of the Contract Agreement. Please sign each and resubmit. Also include 1 copy of the Performance Bond, Payment Bond, Proof of Liability Insurance, Oregon Workers Compensation Certificate of Insurance and a copy of your Statutory Public Works Bond sent to the State of Oregon.

Once the Contract Agreements have been signed by the City Manager, one fully signed Contract Agreement will be given to you at the preconstruction meeting set for _____, 2026 at City Hall.

We look forward to working with you on this project.

Sincerely,

CITY OF SHERWOOD

By: _____

Sofi Lam, P.E.
Civil Engineer



**BUREAU OF LABOR AND INDUSTRIES
NOTICE OF PUBLIC WORKS**
(For use by public agencies in complying with ORS 279C.835)

| |
|--|
| For Office Use Only: Project DB #: _____ |
|--|

NOTE: ORS 279C.835 requires that public contracting agencies include with this form a copy of the disclosure of first-tier subcontractors submitted pursuant to ORS 279C.370.

PUBLIC AGENCY INFORMATION

Agency Name: _____
Agency Division: _____ Agency # (if known): _____
Address: _____
City, State, Zip: _____
Email Address: _____
Agency Representative: _____ Phone: _____

SECTION A: To be completed when a public agency awards a contract to a contractor for a public works project, including CM/GC projects. (See reverse for public works projects in which no public agency awards a contract to a contractor.)

CONTRACT INFORMATION:

Project Name: _____
Contract Name (if part of larger project): _____
Project #: _____ Contract #: _____
Project Manager Name: _____ Phone: _____ Fax: _____
Project Location (Street(s), City): _____ Project County: _____
Date specifications first advertised for bid (if not advertised, date of RFP or first contact with contractor): _____
OR If CM/GC contract, date contract became a public works contract (see OAR 839-025-0020(8)): _____
Contract Amount: \$ _____
Is this contract part of a larger project? YES NO If yes, total project amount: \$ _____
If yes, **INITIAL** date specifications for project advertised for bid (see OAR 839-025-0020(6)(b)): _____
Will project use federal funds that require compliance with the Davis-Bacon Act? YES NO
Date Contract Awarded: _____ Date Work Expected to Begin: _____ Date Work Expected to be Complete: _____

PRIME CONTRACTOR INFORMATION:

Name: _____
Address: _____
City, State Zip: _____ Phone: _____
Construction Contractors Board Registration #: _____
Name of Bonding Company for Payment Bond: _____
Address: _____
Agent Name: _____ Phone: _____ Payment Bond # _____
 Copy of first-tier subcontractors attached (see NOTE above).

Signature of agency representative completing form: _____
Printed Name: _____ Phone: _____ Date: _____
Email Address: _____

THIS FORM WILL BE RETURNED TO THE PUBLIC AGENCY FOR CORRECTION AND RESUBMITTAL IF INCOMPLETE.

Complete this page for public works projects in which NO PUBLIC AGENCY AWARDS A CONTRACT TO A CONTRACTOR. Complete the CONTRACT INFORMATION AND SECTION B, C, D or E, whichever applies to the project.

CONTRACT INFORMATION:

Name of Project Owner: _____ Phone: _____
Project Name: _____ Project #: _____
Project Location (Street(s), City): _____ Project County: _____
Total Project Cost: \$ _____ Amount of Public Funds Provided for the Project: \$ _____
Name(s) of Public Agency(ies) Providing Public Funds: _____
Will project use federal funds that require compliance with the Davis-Bacon Act? YES NO
Date Work Expected to Begin: _____ Date Work Expected to be Complete: _____

SECTION B: To be completed when a project is a public works pursuant to ORS 279C.800(6)(a)(B) (a project for the construction, reconstruction, major renovation or painting of a road, highway, building, structure or improvement of any type **that uses \$750,000 or more of funds of a public agency**).

Date the public agency or agencies committed to the provision of funds for the project: _____

SECTION C: To be completed when a project is a public works pursuant to ORS 279C.800(6)(a)(C) (a project for the construction of a privately owned road, highway, building, structure or improvement of any type **that uses funds of a private entity and in which 25 percent or more of the square footage of the completed project will be occupied or used by a public agency**).

Total square footage of privately owned road, highway, building, structure or improvement: _____
Percent of total square footage of the completed project that will be occupied or used by a public agency: _____
Date the public agency or agencies entered into an agreement to occupy or use the completed project: _____

SECTION D: To be completed when a project is a public works pursuant to ORS 279C.800(6)(a)(D) (a project that includes the construction or installation of a **device, structure or mechanism that uses solar radiation** on public property, regardless of project cost or whether the project uses funds of a public agency).

Date the public agency entered into an agreement for the project: _____

SECTION E: To be completed when a project is a public works pursuant to ORS 279C.800(6)(a)(E) (a project for the construction, reconstruction, major renovation or painting of a road, highway, building, structure, or improvement of any type that occurs, with or without using funds of a public agency, **on real property that a public university listed in ORS 352.002 owns**).

Date the public agency entered into an agreement for the project: _____

Signature of agency representative completing form: _____

Printed Name: _____ Phone: _____ Date: _____

Email Address: _____

THIS FORM WILL BE RETURNED TO THE PUBLIC AGENCY FOR CORRECTION AND RESUBMITTAL IF INCOMPLETE.

RETURN THIS COMPLETED FORM TO:

Prevailing Wage Rate Unit • Oregon Labor & Industries • 800 NE Oregon Street, #1045 • Portland, OR 97232-3601
Telephone (971) 673-0852 • FAX (971) 673-0769 • pwremail@boli.state.or.us



**Public Works Division
Engineering Department**
22560 SW Pine St.
Sherwood, OR 97140
503-925-2309

NOTICE TO PROCEED

PROJECT NAME: 2nd & Park Regional Storm Facility Rehab
DATE: April XX, 2026
PROJECT NO.:
COUNCIL RESOLUTION: 2026-XXX
C.O.S. PROJECT MANAGER: Sofi Lam, P.E.

TO: _____
Attn: _____

ADDRESS: _____

PHONE/EMAIL: (503) – [email](#) address

CONTRACT: City of Sherwood and XXX

2nd & Park Regional Storm Facility Rehab

You are hereby notified that the Contract for the aforementioned project has been properly executed; performance and payment bonds and proof of insurance has been received.

In accordance with the Contract Agreement, all Contract Work shall be completed by the completion date described in the Bid Booklet on or before July 10, 2026 which is ____ calendar days from the issuance of this Notice to Proceed.

CITY OF SHERWOOD

Sofi Lam, P.E.
Project Manager

Division Three

General Requirements

PREVAILING WAGE RATES
FOR
PUBLIC WORKS CONTRACTS IN OREGON

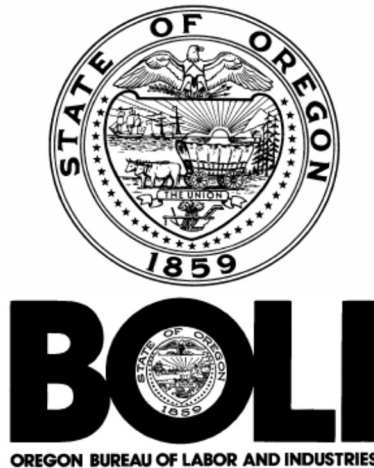

BOLI PREVAILING WAGE RATES (PWR)

This Project is subject to Oregon Bureau of Labor and Industry – Prevailing Wage Rates for Public Works Projects in Oregon, effective January 5, 2026 as well as the most recent wage amendments and apprentice rates published February 18, 2026.

This publication is available on the web at:

<https://www.oregon.gov/boli/employers/Pages/prevailing-wage-rates.aspx>

This is a local project. No Federal Funds are being used on this project. Therefore the project is not subject to the Davis-Bacon Act (40 U.S.C. 3141 et seq.).

GENERAL REQUIREMENTS

STANDARD SPECIFICATION

The Oregon Standard Specifications for Construction 2024 edition, as issued by the Oregon Department of Transportation, as amended herein, these Special Provisions, the Advertisement of Bids, the Accepted Proposal, the Agreement, the Special Specifications, the Plans, the Standard Details appended hereto, and all addenda issued prior to the execution of the agreement and all modifications thereto comprise the Contract documents or the contract.

CONSTRUCTION CONTRACTORS BOARD

The contractor must:

- (a) Have a public works bond filed with the Construction Contractors Board before starting work on the project, unless exempt under ORS 279C.836 (4), (7), (8) or (9).
- (b) Require, in every subcontract, that the subcontractor have a public works bond filed with the Construction Contractors Board before starting work on the project, unless exempt under ORS 279C.836 (4), (7), (8) or (9).

Division Four

Special Provisions

TABLE OF CONTENTS FOR SPECIAL PROVISIONS

| | |
|--|----|
| WORK TO BE DONE | 1 |
| APPLICABLE SPECIFICATIONS | 1 |
| CLASS OF PROJECT | 1 |
| PART 00100 – GENERAL CONDITIONS | |
| SECTION 00110 – ORGANIZATION, CONVENTIONS, ABBREVIATIONS AND DEFINITIONS | 2 |
| SECTION 00120 – BIDDING REQUIREMENTS AND PROCEDURES | 2 |
| SECTION 00130 – AWARD AND EXECUTION OF CONTRACT | 7 |
| SECTION 00140 – SCOPE OF WORK | 8 |
| SECTION 00150 – CONTROL OF WORK | 9 |
| SECTION 00160 – SOURCE OF MATERIALS | 13 |
| SECTION 00165 – QUALITY OF MATERIALS | 13 |
| SECTION 00170 – LEGAL RELATIONS AND RESPONSIBILITIES | 13 |
| SECTION 00180 – PROSECUTION AND PROGRESS | 14 |
| SECTION 00190 – MEASUREMENT OF PAY QUANTITIES | 19 |
| SECTION 00195 – PAYMENT | 19 |
| SECTION 00196 – PAYMENT FOR EXTRA WORK..... | 20 |
| SECTION 00197 – PAYMENT FOR FORCE ACCOUNT WORK..... | 20 |
| SECTION 00199 – DISAGREEMENTS, PROTESTS, AND CLAIMS..... | 21 |
| PART 00200 – TEMPORARY FEATURES AND APPURTENANCES | |
| SECTION 00210 – MOBILIZATION..... | 23 |
| SECTION 00220 – ACCOMMODATIONS FOR PUBLIC TRAFFIC | 23 |
| SECTION 00221 – COMMON PROVISIONS FOR WORK ZONE TRAFFIC CONTROL | 24 |
| SECTION 00280 – EROSION AND SEDIMENT CONTROL | 25 |
| SECTION 00290 – ENVIRONMENTAL PROTECTION..... | 26 |
| PART 00300 – ROADWORK | |
| SECTION 00305 – CONSTRUCTION SURVEY WORK..... | 28 |
| SECTION 00310 – REMOVAL OF STRUCTURES AND OBSTRUCTIONS..... | 29 |
| SECTION 00320 – CLEARING AND GRUBBING..... | 30 |
| SECTION 00330 – EARTHWORK..... | 31 |
| SECTION 00350 – GEOSYNTHETIC INSTALLATION..... | 32 |
| SECTION 00390 – RIPRAP PROTECTION..... | 33 |
| PART 00400 – DRAINAGE AND SEWER | |
| SECTION 00470 – MANHOLES, CATCH BASINS AND INLETS | 33 |
| SECTION 00490 – WORK ON EXISTING SEWERS AND STRUCTURES | 34 |
| PART 00600 – BASES | |
| SECTION 00640 – AGGREGATE BASE AND SHOULDERS | 35 |
| PART 00700 – WEARING SURFACES | |
| SECTION 00759 – MISCELLANEOUS PORTLAND CEMENT CONCRETE STRUCTURES | 35 |
| PART 01000 – RIGHT OF WAY DEVELOPMENT AND CONTROL | |
| SECTION 01030 – SEEDING..... | 35 |
| SECTION 01040 – PLANTING..... | 36 |
| PART 02000 – MATERIALS | |
| SECTION 02001 – CONCRETE | 39 |
| SECTION 02010 – PORTLAND CEMENT | 39 |
| SECTION 02020 – WATER..... | 39 |

| | |
|--|----|
| SECTION 02030 – SUPPLEMENTARY CEMENTITIOUS MATERIALS | 39 |
| SECTION 02040 – CHEMICAL ADMIXTURES | 39 |
| SECTION 02050 – CURING MATERIALS..... | 39 |
| SECTION 02080 – GROUT..... | 39 |
| SECTION 02320 – GEOSYNTHETICS | 39 |
| SECTION 02415 – PLASTIC PIPE | 39 |
| SECTION 02440 – JOINT MATERIALS | 39 |
| SECTION 02510 – REINFORCEMENT | 40 |
| SECTION 02560 – FASTENERS..... | 40 |
| SECTION 02630 – BASE AGGREGATE..... | 40 |
| SECTION 02690 – PCC AGGREGATES | 40 |
| | |
| PART 03000 – MATERIALS | |
| SECTION 03020 – EROSION MATERIALS | 40 |

SPECIAL PROVISIONS

WORK TO BE DONE

This project is called 2nd and Park Regional Storm Facility Project and is located in the City of Sherwood, Washington County, Oregon. The Work to be done under this Contract consists of the following:

Project Description

The Work to be done under this Contract consists of the following:

1. Concrete weir box modifications.
2. Riprap removal and reuse.
3. Regrading of the storm facility.
4. Removal and reconstruction of concrete flow spreaders.
5. Removal and replanting of storm facility vegetation.
6. 2-Year plant establishment.
7. Traffic control.
8. Utility vault lid and weir box riprap removal (bid alternate).
9. Other miscellaneous items for completion of work.

APPLICABLE SPECIFICATIONS

The Specification that is applicable to the Work on this Project is the 2024 edition of the "Oregon Standard Specifications for Construction".

All number references in these Special Provisions shall be understood to refer to the Sections and subsections of the Standard Specifications and Supplemental Specifications bearing like numbers and to Sections and subsections contained in these Special Provisions in their entirety.

CLASS OF PROJECT

This is a City of Sherwood Project. The construction of this project is not federally funded.

PART 00100 – GENERAL CONDITIONS

SECTION 00110 – ORGANIZATION, CONVENTIONS, ABBREVIATIONS AND DEFINITIONS

Comply with Section 00110 of the Standard Specifications modified as follows:

Remove the following definitions and replace as noted:

00110.20 Definitions –

Bid Booklet – The bidding documents bound with the Solicitation Documents that contain the information identified in 00120.10.

Bid Section – The portion of the Solicitation Documents labeled, Division One - Bidding Requirements.

Add the following definitions:

Bid Proposal – The bidding forms included in Division One - Bidding Requirements of the Solicitation Documents as identified in 00120.10.

SECTION 00120 – BIDDING REQUIREMENTS AND PROCEDURES

Comply with Section 00120 of the Standard Specifications modified as follows:

Remove the text from the following subsection and replace with the following:

00120.00 Prequalification of Bidders - Bidders must be **pre-qualified** in accordance with the laws of the State of Oregon. Letters of pre-qualification (approval letter only) by either the Oregon Department of Transportation (ODOT), Washington County Department of Transportation, or any local municipality with a population equal to or greater than 18,000 persons is acceptable to the City. Proof of valid pre-qualification must be submitted to the City **by Tuesday, April 7, 2026 at 4:00 PM (local time)** for the Bidder's Bid to be deemed responsive and to retain appeal rights. Only bids from pre-qualified Bidders will be opened.

All companies working on the project must possess either a Metro license or a City of Sherwood business license in accordance with the Sherwood Municipal Code at the time of construction.

Remove the text from the following subsection and replace with the following:

00120.05 Requests for Solicitation Documents –

Solicitation documents may be obtained as specified in the Invitation To Bid.

Remove the text from the following subsection and replace with the following:

00120.10 Bid Booklet –

The Bidding Documents are bound with the Solicitation Documents and labeled as Division One – Bidding Requirements. The bidding Documents may include, but are not limited to:

- Invitation to Bid
- Bidder's Checklist
- Bid Statement
- Bid Schedule
- First Tier Subcontractor Disclosure Form
- Bid Bond
- Certificate of Non-Collusion
- Compliance with ORS 279C.840
- Certification of Asbestos Abatement
- Certificate of Non-Discrimination
- Customer Service Acknowledgment
- Prequalification Acknowledgement
- Bidder Responsibility Form
- Addendum Acknowledgment (Example)

Modify the third paragraph of the following subsection as noted:

00120.15 Examination of Work Site and Solicitation Documents; Consideration of Conditions to be Encountered –

Any clarification of Plans and Specifications needed by the Bidder shall be requested in writing through the Engineer. Requests shall be made ~~in sufficient time~~ at least seven (7) days prior to bid opening for the Agency's reply to reach all Bidders before Bid Closing. Oral explanations or interpretations given before receiving Bids for a Project will not be binding. To be binding, interpretation of the Plans and Specifications by the Agency must be made by written Addendum furnished to all Holders of Bidding Plans according to 00120.30. Notification of erroneous or incomplete Plans or Specifications shall also be submitted to the Engineer. Such notification shall also be made ~~in sufficient time~~ at least seven (7) days prior to bid opening for the Agency to make any necessary modifications and issue Addenda to Bidders prior to Bid Closing.

Revise the first paragraph in the following subsection as noted:

00120.30 Changes to Plans, Specifications, or Quantities before Opening of Bids –

The Agency reserves the right to issue Addenda making changes or corrections to the Plans, Specifications, or quantities. The Agency will provide Addenda only by publishing them on the Agency's web site (www.sherwoodoregon.gov). It is the Bidders responsibility to check the website to receive and review Addenda. ~~See the ODOT web site page included with the Special Provisions for the web site address where the Addenda are available.~~

Modify the text of the following subsection as noted:

**00120.40 Preparation of Bids
(a)(1) Paper Bids**

For Bids submitted by paper, Bidders shall not alter, in any manner, the (paper)

documents within the Bid Section ~~that are accessed and printed from the ODOT eBIDS website (see 00110.05(e)). Bid Sections obtained from BidExpress® shall not be substituted for paper Bid Sections.~~ Bidders shall complete the certifications and statements included in the Bid Section of the Bid Booklet according to the instructions. Signature of the Bidder's authorized representative thereon constitutes the Bidder's confirmation of and agreement to all certifications and statements contained in the Bid Booklet. Entries on paper documents in the Bid Section shall be in ink or typed. Signatures and initials shall be in ink, ~~except for changes and withdrawls submitted by email transmission as provided by 00120.60 (in which case signatures on the scanned document shall be considered originals).~~ The bidder shall properly complete and bind all the paper documents in the Bid Section, as specified in 00120.10, together with all other required documents that are part of the Bid Booklet, between the front and back covers of the Bid Booklet.

No changes shall be submitted by facsimile or email.

Remove the text from the following subsection and replace with the following:

00120.40 Preparation of Bids

(a)(2) Electronic Bids –

Electronic Bids will not be accepted for this project.

Remove the text from the following subsection and replace with the following:

00120.40 Preparation of Bids

(c)(2) Electronic Bids Schedule Entries –

Electronic Bids will not be accepted for this project.

Modify the text of the following subsection as noted:

00120.40(d) Bidder's Address and Signature Pages –

Bidders shall include in the Bid the address to which all communications concerning the Bid and Contract should be sent. The Bid must be signed, ~~or digitally signed, as appropriate, by a duly authorized representative of the Bidder. In addition, the electronic Bid requires the unique ID obtained from BidExpress® and approved by the Agency.~~

Remove the text from the following subsection and replace with the following:

00120.40 Preparation of Bids

(e)(2) Bid Guaranty with Electronic Bids –

Electronic Bids will not be accepted for this project.

Remove the text from the following subsection and replace with the following:

00120.40 Preparation of Bids

(f) Disclosure of First Tier Subcontractors –

Without regard to the amount of a Bidder's Bid, if the Agency's cost range for a public improvement Project in the "Notice to Contractors", or in other advertisement or Solicitation Documents, exceeds \$100,000, the Bidder shall, within 2 working hours of the time Bids are due to be submitted, submit to the Agency, on a form provided by the Agency, a disclosure identifying any first-tier Subcontractors that will furnish labor or labor and Materials, and whose contract value is equal to or greater than:

- 5% of the total Project Bid, but at least \$15,000; or
- \$350,000, regardless of the percentage of the total Project Bid.

For each Subcontractor listed, Bidders shall state:

- The name of the Subcontractor;
- The dollar amount of the subcontract; and
- The category of Work that the Subcontractor would be performing.

If no subcontracts subject to the above disclosure requirements are anticipated, a Bidder shall so indicate by entering "NONE" or by filling in the appropriate check box. For each Subcontractor listed, Bidders shall provide all requested information. Failure to submit a form or submission of a form that does not include the information required by ORS 279C.370 for each Subcontractor listed, specifically the name of each Subcontractor, the dollar amount of each subcontract and the category of Work that each Subcontractor will perform, will result in the rejection of the Bid. The Agency is not required to determine the accuracy or the completeness of the Subcontractor disclosure. See ORS 279C.370 and OAR 731-007-0260.

In the event that multiple Subcontractor Disclosure Forms are submitted, the last version received prior to the deadline will be the intended version.

Bids not in compliance with the requirements of this Subsection will be considered non-responsive.

Remove the text from the following subsection and replace with the following:

00120.45 Submittal of Bids:

(b) Electronic Bids –

No Electronic Bids will be accepted for this project.

Modify the text of the following subsection as noted:

00120.60 Revision or Withdrawal of Bids:

(a) Paper Bids – Information entered into the paper Bid Booklet by the Bidder may be changed after the paper Bid has been delivered to the ~~ODOT Procurement Office~~ appropriate location, provided that:

- Changes are prepared according to the instructions identified in the Bid Booklet; and
- Changes are received at the same offices, addresses, and times identified in the paper Bid Booklet for submitting Bids; and
- The changes are submitted in writing ~~or by electronic facsimile (FAX) transmission to~~

~~the FAX number given in the paper Bid Booklet, and signed by an individual authorized to sign the Bid.~~

A Bidder may withdraw its paper Bid after it has been delivered to the ~~ODOT Procurement Office~~ appropriate location, provided that:

- The written withdrawal request is submitted on the Bidder's letterhead, ~~either~~ by hand delivery ~~or by FAX to the FAX number given in the paper Bid Booklet;~~ and
- The request is signed by an individual who is authorized to sign the Bid, and proof of authorization to sign the Bid accompanies the withdrawal request; and
- The request is received at the same offices, addresses, and times identified in the paper Bid Booklet for submitting Bids.
- No Bid may be withdrawn after the deadline for submitting Bids has passed.

Remove the text from the following subsection and replace with the following:

00120.60 Revision or Withdrawal of Bids:

(b) Electronic Bids –

No Electronic Bids will be accepted for this project.

Remove the text from the following subsection and replace with the following:

00120.70 Rejection of Nonresponsive Bids – A Bid will be considered irregular and will be rejected if the irregularity is deemed by the Agency to render the Bid non-responsive. Examples of irregularities include, without limitation:

- The Bid Section documents provided are not properly used or contain unauthorized alterations.
- The Bid is incomplete or incorrectly completed.
- The Bid contains improper additions, deletions, alternate Bids, or conditions.
- The Bid or Bid modifications are not signed by a person authorized to submit Bids or modify Bids, as required by 00120.01.
- A member of a joint venture and the joint venture submit Bids for the same Project. Both Bids may be rejected.
- The Bid has entries not typed or in ink, or has signatures or initials not in ink.
- Each change or correction is not individually initialed.
- White-out tape or white-out liquid is used to correct item entries.
- The price per unit cannot be determined.
- The Bid guaranty is insufficient or improper.
- The original Bid Bond form is not used or is altered.
- A disclosure of first-tier Subcontractors, if required under 00120.40(f), is not received within 2 working hours of the time Bids are due to be submitted, or the disclosure form is not complete.
- The Bidder has not complied with the DBE requirements of the solicitation.
- The Bid does not acknowledge all issued Addenda.
- The Bid contains entries that are not greater than zero.
- The Bid contains entries with more than two decimals to the right of the decimal point.
- The Bid entries are not expressed in U.S. dollars and cents.

- The Bid is submitted on documents not obtained directly from the City of Sherwood or from the City of Sherwood website. The Agency determines that any Pay Item is significantly unbalanced to the potential detriment of the Agency.

The Agency may reject any or all Bids due to irregularities or may waive irregularities not affecting substantial rights in accordance with OAR 137-049-0350 upon a finding of the Agency that it is in the public interest to do so.

Delete the following subsection in its entirety:

~~**00120.95 Opportunity for Cooperative Arrangement**~~

SECTION 00130 – AWARD AND EXECUTION OF CONTRACT

Comply with Section 00130 of the Standard Specifications modified as follows:

Remove the text from the following subsection and replace with the following:

00130.15 Right to Protest Award:

Adversely affected or aggrieved Bidders, limited to the three apparent lowest Bidder, may submit to the City of Sherwood a written protest of the City's Intent to Award within seven (7) calendar days following the date of the Notice of Intent to Award. The protest shall specify the grounds upon which it is based.

An aggrieved Bidder may protest an award only if the Bidder alleges, in its written protest, that it should have received the award because:

- All lower Bids are non-responsive;
- The Agency failed to conduct the Bid process as described in the Bid document;
- The Agency has abused its discretion in rejecting the protestor's Bid as non-responsive or non-responsible; or
- The Agency's evaluation of Bids or subsequent determination of award is otherwise in violation of ORS Chapter 279C or the Agency's public contracting rules.

The written protest must describe the facts that support the protest. The Agency may not consider late protests or protests that do not describe facts that would support a finding that the Bidder is aggrieved for one of the reasons cited above.

Remove the second paragraph from the following subsection and replace with the following:

00130.40 Contract Submittals –

(b) Certificates of Insurance

For this Contract, the Agency may request at any time a certified copy of any insurance policy that this Contract requires and Contractor will provide same at its sole cost within ten (10) days of Agency's request.

Add the following Subsection:

00130.40 Contract Submittals –

(f) State of Oregon Statutory Public Works Bond

As particularly described in 00170.20, when awarded the contract, the successful Bidder shall furnish a State of Oregon Statutory Public Works Bond.

SECTION 00140 – SCOPE OF WORK

Comply with Section 00140 of the Standard Specifications supplemented and/or modified as follows:

Add the following Subsection:

00140.31 As-Built Records – Contractor shall maintain a current and accurate record of the work completed during the course of this contract. This may be in the form of “as-built” drawings kept by accurately marking a designated set of the contract plans with the specified information as the Work proceeds.

Accurate, complete and current “as-built” drawings are a specified requirement for full payment of the work completed. At project completion and as a condition of final payment, the Contractor shall deliver to the Project Manager a complete and legible set of “as-built” drawings.

The “as-built” drawings must show the information listed below. Where the term “locate” or “location” is used, it shall mean record of position with respect to both the construction vertical datum and either construction horizontal datum or a nearby permanent improvement.

1. Record location of underground services and utilities as installed.
2. Record location of existing underground utilities and services that are to remain and that are encountered during the course of the work.
3. Record changes in dimension, location, grade or detail to that shown on the plans.
4. Record changes made by change order
5. Record details not in the original plans
6. Provide fully completed shop drawings reflecting all revisions

Add the following text to the following subsection:

00140.70 Cost Reduction Proposals –

Unless otherwise agreed to in writing by the Agency, a proposal that is solely or primarily a proposal to reduce estimated quantities or delete Work, as determined by the Engineer, is not eligible for consideration as a cost reduction proposal and will instead be addressed under 00140.30, whether proposed or suggested by the Agency or the Contractor.

Proposed changes by the Agency are not eligible for consideration as a cost reduction proposal and will instead be addressed under 00140.30.

Add the following bulleted item to the following subsection:

00140.90 Final Trimming and Cleanup

- Removal and clean-up of erosion and sediment controls facilities, once vegetation is established on disturbed areas of Project Site and the Project Site has been stabilized.

SECTION 00150 – CONTROL OF WORK

Comply with Section 00150 of the Standard Specifications supplemented and/or modified as follows:

Remove the text from the following subsection and replace with the following:

00150.10 Coordination of Specifications and Plans –

(a) Order of Precedence – The Engineer will resolve any discrepancies between these documents in the following order of precedence:

- Contract Change Orders;
- Permits from governmental agencies;
- Addenda
- Special Provisions;
- Contract Agreement
- Agency-prepared drawings specifically applicable to the Project and bearing the Project title;
- Reviewed and accepted, stamped Working Drawings;
- Standard Drawings;
- Approved Unstamped Working Drawings;
- Supplemental Specifications/Special Provisions;
- Standard Specifications; and
- All other contract documents not listed above.

Engineer provided notes on a drawing shall take precedence over drawing details.

Engineer provided dimensions shown on the drawings, or that can be computed, shall take precedence over scaled dimensions.

Remove the text from the following subsection and replace with the following:

00150.15 Construction Stakes, Lines and Grades

The Contractor shall establish all field controls for the project and furnish all principal lines, grades, and measurements necessary for the completion of the Work. An electronic copy of the base drawing will be available for the construction staking of this project. All necessary calculations for staking shall be provided by the Contractor's surveyor. All stakes damaged or removed shall be replaced, as needed, at no cost to the City.

The Contractor shall inform the Engineer of any property corners, monuments and/or survey markers found during construction activities that are not shown on the plans. The Contractor

shall not bury or disturb any property corners, monuments and/or survey markers. If disturbance of any property corners, monuments and/or survey markers is necessary, then the Contractor shall contact the City Project Manager prior to any removal of any property corners or monuments. Property corners or monuments shall be restored in compliance with all rules and regulations by an Oregon licensed land surveyor.

Remove the text of the following subsection and replace with the following:

00150.30 Delivery of Notices –

Written notices to the Contractor by the Engineer or the Agency will be delivered:

- In person;
- By email.

Add the following text to the following subsection as noted:

00150.35 Plans, 3D Engineered Models, Working Drawings, and 3D Construction Models:

(d)(1) Stamped Working Drawings –

Stamped Working Drawings will be designated as "reviewed and accepted" or "reviewed with comments" by the Engineer.

Remove the text from the following subsection and replace with the following:

00150.40 Cooperation and Superintendence by the Contractor –

The Contractor is responsible for full management of all aspects of the Work, including superintendence of all Work by Subcontractors, Suppliers, and other providers. The Contractor shall appoint a single Superintendent and may also appoint alternate Superintendents as necessary to control the Work. The form of appointment of the alternate shall state, in writing, the alternate's name, duration of appointment in the absence of the Superintendent, and scope of authority. The Contractor shall:

(a) Provide for the cooperation and superintendence on the Project by:

- Furnishing the Engineer all data necessary to determine the actual cost of all or any part of the Work, added Work, or changed Work.
- Allowing the Engineer reasonable access to the Contractor's books and records at all times. To the extent permitted by public records laws, the Engineer will make reasonable efforts to honor the Contractor's request for protection of confidential information.
Keeping one complete set of Contract Documents on the Project Site at all times, available for use by all the Contractor's own organization, and by the Engineer if necessary.

(b) Appoint a single Superintendent and any alternate Superintendent who shall meet the following qualifications:

- Appointees shall be competent to manage all aspects of the Work.
- Appointees shall be from the Contractor's own organization.

- Appointees shall have performed similar duties on at least one previous project of the size, scope and complexity as the current Contract.
- Appointees shall be experienced in the types of Work being performed.
- Appointees shall be capable of reading and thoroughly understanding the Plans and Specifications.

(c) The appointed single Superintendent, or any alternate Superintendent shall:

- Be present for all On-Site Work, regardless of the amount to be performed by the Contractor, Subcontractors, Suppliers, or other providers, unless the Engineer provides prior approval of the Superintendent's or alternate Superintendent's absence.
- Be equipped with a two way radio or cell phone capable of communicating throughout the project during all the hours of Work on the Project Site and be available for communication with the Engineer.
- Have full authority and responsibility to promptly execute orders or directions of the Engineer.
- Have full authority and responsibility to promptly supply the Materials, Equipment, labor, and Incidentals required for performance of the Work.
- Coordinate and control all Work performed under the Contract, including without limitation the Work performed by Subcontractors, Suppliers, and Owner/Operators.
- Diligently pursue progress of the Work according to the schedule requirements of Section 00180.
- Cooperate in good faith with the Engineer, Inspectors, and other contractors in performance of the Work.
- Provide all assistance reasonably required by the Engineer to obtain information regarding the nature, quantity, and quality of any part of the Work.
- Provide access, facilities and assistance to the Engineer in establishing such lines, grades and points as the Engineer requires.
- Carefully protect and preserve the Engineer's marks and stakes.

Any Superintendent or alternate Superintendent who repeatedly fails to follow the Engineer's written or oral orders, directions, instructions, or determinations, shall be subject to removal from the project.

If the Contractor fails or neglects to provide a Superintendent, or an alternate Superintendent, and no prior approval has been granted, the Engineer has the authority to suspend the Work according to 00180.70. Any continued Work by the Contractor, Subcontractors, Suppliers, or other providers may be subject to rejection and removal. The Contractor's repeated failure or neglect to provide the superintendence required by these provisions constitutes a material breach of the Contract, and the Engineer may impose any remedies available under the Contract, including but not limited to Contract termination.

Remove the text from the following subsection and replace with the following:

00150.50 Cooperation with Utilities:
(b) Agency Responsibilities –

The contractor shall coordinate with franchise utility companies for any installation of new franchise utility facilities and any connection to existing franchise utility facilities.

The appropriate franchise utility company shall be contacted if any conflicts occur with the franchise utility during construction.

Add the following text to the following subsection as noted:

00150.95 Final Acceptance

Once the construction work is complete, all systems are operable, and final inspection discloses no deficiencies or inconsistencies with the Work as provided in the Contract Documents, the following documentation shall be delivered to the Engineer prior to issuing of Third Notification:

- Special guarantees and bonds;
- Separate waivers of liens for subcontractor, supplies, and other with lien rights against property of owner;
- Final pay estimate;
- Releases from BOLI;
- Evidence that the Maintenance Bond will remain in effect for two years following the date of Final Acceptance;
- Red-lined as-built drawings showing locations of all improvements constructed as part of this project.

Add the following text to the following subsection as noted:

00150.96 Maintenance Warranties and Guarantees

The Contractor shall provide a 10% Maintenance Bond for a period of two (2) years from the date of final acceptance by the Agency. A surety licensed to do business as a surety in the state of Oregon shall provide the Maintenance Bond.

The acceptance by the Contractor of final payment shall be and shall operate as a release to the Agency of all claims and all liability to the Contractor other than claims in stated amounts as may be specifically excepted by the Contractor in writing prior to the request for final payment for all things done or furnished in connection with this work and for every act and neglect of the Agency and its agents and others relating to or arising out of this work. However, any payment, final or otherwise, or any acceptance, shall not release the Contractor or its sureties from any obligations under the Contract Documents or the Performance and Payment Bonds or diminish the Agency's rights under the guaranty provisions.

In addition to and not in lieu of any other warranties required under the Contract make all necessary repairs and replacements to remedy, in a manner satisfactory to the Engineer and at no cost to the Agency, any and all defects, breaks, or failures of the Work occurring during the specified warranty period due to faulty or inadequate materials or workmanship. Repair damage or disturbance to other improvements under, within, or adjacent to the Work, whether or not caused by settling, washing, or slipping, when such damage or disturbance is caused, in whole or in part, from activities of the Contractor in performing his duties and obligations under this Contract when such defects or damage occur within the warranty period. The required two-year maintenance period shall, with relation to such required repair, be extended one year from the date of completion of such repair when the repair occurs after

the first year of the warranty period.

If Contractor, after written notice, fails within ten days to proceed to comply with the terms of this section, Agency may have the defects corrected, and Contractor and Contractor's Surety shall be liable for all expense incurred. In case of an emergency where, in the opinion of the Engineer, delay would cause serious loss or damage, repairs may be made without notice being given to Contractor and Contractor or Surety shall pay the cost of repairs. Failure of the Engineer to act in case of an emergency shall not relieve Contractor or Surety from liability and payment of all such costs.

SECTION 00160 – SOURCE OF MATERIALS

Comply with Section 00160 of the Standard Specifications.

SECTION 00165 – QUALITY OF MATERIALS

Comply with Section 00165 of the Standard Specifications.

SECTION 00170 – LEGAL RELATIONS AND RESPONSIBILITIES

Comply with Section 00170 of the Standard Specifications modified as follows:

Add the following text to the following subsection as noted:

00170.70(a) Insurance Coverages –

The following insurance coverages and dollar amounts are required pursuant to this subsection:

| Insurance Coverages | Combined Single Limit per Occurrence | Annual Aggregate Limit |
|---------------------------------|---|-------------------------------|
| Commercial General Liability | \$2,000,000.00 | \$2,000,000.00 |
| Commercial Automobile Liability | \$2,000,000.00 | \$2,000,000.00 |

Add the following text to the following subsection as noted:

00170.70(c) Additional Ensured –

Add the following as Additional Insureds under the Contract:

The City of Sherwood and its officers, agents, and employees.
Sherwood City Council.

Clean Water Services and its officers, agents, and employees.

Add the following text to the following subsection as noted:

00170.72 Indemnity/Hold Harmless –

Extend indemnity and hold harmless to the Agency and the following:

The City of Sherwood and its officers, agents, and employees.
Sherwood City Council.

Clean Water Services and its officers, agents, and employees.

SECTION 00180 – PROSECUTION AND PROGRESS

Comply with Section 00180 of the Standard Specifications modified as follows:

Delete the following subsection:

00180.20(a) – Subcontracting Limitations, General

Remove the text from the following subsection and replace with the following:

00180.21 Subcontracting:

(a) General - The Contractor shall not subcontract or perform any portion of the Contract by other than the Contractor's own organization without the Agency's prior written consent. A request for consent to subcontract, at any tier, solely for the furnishing of a labor force will not be considered.

A written request for consent to subcontract any portion of the Contract at any tier shall be submitted to the Engineer, and when required by the Engineer, shall be accompanied by background information showing that the organization proposed to perform the Work is experienced and equipped for such Work. The Agency will review the Contractor's submission to verify compliance with Contract requirements, confirm the percentage of Work subcontracted, and evaluate the proposed Subcontractor's ability to perform the Work.

If the Engineer revokes consent to subcontract, the Subcontractor shall be immediately removed from the Project Site.

Add the following bulleted items to the following subsection:

00180.40 Limitation of Operations:

(a) In General –

- Limited hours of construction between 8:00 AM until 6:00 PM, Monday through Friday. Except as otherwise noted in the Bid Drawings.
- Construction is prohibited on Saturdays and Sundays without prior written approval from the Engineer.

- Construction activities include all field maintenance of equipment, refueling, and pick-up and delivery of equipment, as well as actual construction activities.
- Construction vehicles shall park on the construction site, at location(s) indicated on the Contract Drawings, or at location(s) approved by the Agency. Contractor parking shall not interfere with the everyday operations of the surrounding area.
- Provide the Agency Project Manager with a 24-hour emergency contact person's name and telephone number.

Add the following subsection:

00180.40(c) Specific Limitations –

Limitations of operations specified in these Special Provisions include, but are not limited to, the following:

| Limitations | Subsection |
|---|-------------------|
| Cooperation with Utilities..... | 00150.50 |
| Cooperation with Other Contractors..... | 00150.55 |
| Contract Completion Time..... | 00180.50(h) |
| Right-of-Way and Access Delays..... | 00180.65 |
| Traffic Lane Restrictions..... | 00220.40(e) |

Add the following text to the following subsection:

00180.41 Project Work Schedules:

The Contractor shall submit a supplemental "look ahead" Project Work schedule each week to the Engineer. The "look ahead" Project Work schedule is supplemental to the Type A, B, or C schedule specified below. The supplemental "look ahead" Project Work schedule shall:

- Identify the sequencing of activities and time required for prosecution of the Work.
- Provide for orderly, timely, and efficient prosecution of the Work.
- Contain sufficient detail to enable both the Contractor and the Engineer to plan, coordinate, analyze, document, and control their respective Contract responsibilities.

The supplemental "look ahead" Project Work schedule shall be written in common terminology and show the planned Work activities broken down into logical, separate activities by area, stage, and size and include the following information:

- The resources the Contractor, subcontractors, or services will use.
- The locations of each activity that will be done including the limits of the work by mile posts, stations, or other indicators.
- The time frames of each activity by Calendar Days, shifts, and hours.
- All anticipated shoulder, lane, and road closures.

At a minimum, the Contractor shall prepare a bar chart that:

- Shows at least three weeks of activity including the week the bar chart is issued.

- Uses a largest time scale unit of one Calendar Day. Smaller time scale units may be used if needed.
- Is appropriate to the activities.
- Identifies each Calendar Day by month and day.

Include the Contract name, Contract number, Contractor's name, and date of issue on each page of the bar chart.

The Contractor shall submit the supplemental "look ahead" Project Work schedule starting at First Notification and continuing each week until Second Notification has been issued and all punch list items and final trimming and clean up has been completed. The Contractor shall meet with the Engineer each week to review the supplemental "look ahead" Project Work schedule. If the Engineer or the Contractor determines that the current supplemental "look ahead" Project Work schedule requires changes or additions, either notations can be made on the current schedule or the Engineer may require the submittal of a revised supplemental "look ahead" Project Work schedule. Review of the current and subsequent supplemental "look ahead" Project Work schedules does not relieve the Contractor of responsibility for timely and efficient execution of the Contract.

A Type "B" schedule as detailed in the Standard Specifications is required on this Contract.

Add the following text to the following subsection:

180.41(b)(2) Detailed Schedule -

The Contractor shall submit an updated project work schedule with all pay requests unless approved otherwise in writing by the Engineer. Payments to the Contractor may be held or delayed until an updated schedule has been received.

The Project Work schedule shall also address the sequencing of critical activities and shall identify the critical path for the project, critical milestones in accomplishing the work and fixed completion dates for those milestones.

Add the following subsection:

00180.41(b)(4) Weekly Schedule – Submit a weekly progress schedule to Engineer at each weekly meeting. At a minimum, the schedule shall include the following:

- Actual work completed during the previous week alongside the previously submitted weekly schedule;
- Any lane closures or access restrictions expected within the next two weeks;
- Work to be completed during the current week;
- Tentative work to be completed during the second week;
- Summary of any work elements shown on the schedule which fall behind the current overall project schedule and a summary of corrective actions that the Contractor will utilize to regain the overall project schedule.

Add the following subsection:

00180.41(b)(5) Customer Service Element to Construction Schedule – Construction will be executed with the highest level of customer service. Critical to that effort is planning of work sequence to minimize disruption and inconvenience to residents and commuter traffic. As a supplement document to the Contractor’s construction schedule, the contractor shall submit, prior to the pre-construction conference, a plan to the Engineer that identifies: construction sequencing and timing, expected disruptions to residents, and a public safety plan that explains procedures on how the Contractor will maintain safe continuous ingress and egress for pedestrians and vehicular traffic including personal use by residents, mail and newspaper delivery, garbage collection and other daily deliveries, as applicable.

Remove the text from the following subsection and replace with the following:

00180.42 Preconstruction Conference:

Within seven (7) working days of the Notice of Award, the Contractor is required to contact the Agency to schedule the preconstruction conference.

In addition to the Contractor, the intended project superintendents, subcontractor foremen and major suppliers – those who will actually be involved in construction activities – should attend the preconstruction conference. The Contractor must be prepared for a thorough discussion and review, as well as revision, which may be deemed necessary in the opinion of the Engineer, of the following:

(Note: These materials SHALL be brought to the preconstruction conference for discussion followed by Engineer review. Some items may also require submittal in advance of the preconstruction meeting per the specifications.)

- Contractor’s plan of operation and progress schedule (3+ copies)
- List of 24 hour emergency phone numbers for the project manager, site foreman, and traffic control supervisor
- List of subcontractors, names, addresses and phone numbers
- List of quality control subcontractor(s), name(s), address(s) and phone number(s)
- List of materials fabricated or manufactured off the project
- Material sources for the project
- Names of principal suppliers
- Detailed equipment list
- “Project Labor List” for all employee classifications anticipated to be used on project
- Cost percentage breakdown for lump sum bid item(s)
- Shop drawings (bring preliminary list)
- Traffic Control Plans (3+ copies)
- Erosion and Sediment Control Plan (3+ copies)
- Pollution Control Plan (3+ copies)
- Sewer Bypass Plan (3+ copies)
- Proposed site for waste material disposal and any necessary permits required for placing this material
- Proposed truck haul route

During the preconstruction conference, be prepared to discuss the following items:

- Bonds and Insurance
- Weekly project meetings – schedule and responsibilities
- Provision for inspection for materials from outside sources
- Responsibility for locating utilities
- Responsibility for damage
- Time schedule for relocations, if by other than Contractor (coordinate with utilities)
- Compliance with Contract Documents
- Hours of work
- Acceptance and approval of work
- Labor compliance, payrolls, and certifications
- Safety regulations for Contractor's and Owner's employees and representatives
- Suspension of work, time extensions
- Change order procedures
- Progress estimates – procedures for payment
- Special requirements of funding agencies
- Construction engineering, advance notice of special work
- Any interpretation of the Contract Documents requested by the Contractor
- Any conflicts or omissions in the Contract Documents
- Any other problems or questions concerning the work
- Processing and administration of public complaints
- Right-of-way, Easements and Temporary Construction Easements

In addition to the preconstruction conference, the City reserves the right to require the Contractor to attend a construction kick-off public open house/presentation wherein the Contractor shall be prepared to present and discuss all elements of the project's construction with the general public.

Add the following Subsection:

00180.50(h) Contract Time –

All Work under the contract, except vegetation establishment, must be completed by September 18, 2026.

Work on this project may not commence until after the contract is signed by both the contractor and the City. City Council approval and expiration of the 7-day protest period is required prior to the City Manager signing the contract. City Council approval of the resolution for the City Manager to sign the contract is anticipated to occur **April 21, 2026**, at the City Council Meeting. Expiration of the protest period is anticipated to occur on **April 20, 2026**.

Add the following text to the following subsection:

00180.85(b) Liquidated Damages –

The liquidated damages for failure to complete the Work on time required by 00180.50(h) will be \$800 per Calendar Day.

Delete the following subsection:

00180.85(b)(1) Single Contract Time

Delete the following subsection:

00180.85(b)(2) Multiple Contract Times

SECTION 00190 – MEASUREMENT OF PAY QUANTITIES

Comply with Section 00190 of the Standard Specifications modified as follows:

Remove the text from the following subsection and replace with the following:

00190.20(g) Agency-Provided Weigh Technician –

The Agency will not provide for a weigh technician. The Contractor shall provide, and pay for, a weigh technician for a vehicle weigh scale. The Contractor's weigh technician will:

- Determine tare weights;
- Prepare weigh memos for each load;
- Compile the weigh records; and
- Not participate in the production of Materials or the loading of haul vehicles.

Contractor shall submit weigh records to project engineer prior to any progress payment.

SECTION 00195 – PAYMENT

Comply with Section 00195 of the Standard Specifications modified as follows:

Remove the text from the following subsection and replace with the following:

00195.12 Steel Materials Price Escalation/De-Escalation Cause – No Pay Items under this Contract qualify for the steel escalation/de-escalation program for this Project.

Remove the text from the following subsection and replace with the following:

00195.50(c) Forms of Retainage

- (1) Cash, Alternate A** - Retainage will be deducted from progress payments and held by the Agency until final payment is made according to 00195.90, unless otherwise specified in the Contract.

The Agency will deposit the cash retainage withheld in an interest-bearing account in a bank, savings bank, trust company, or savings association for the benefit of the Agency, as provided by ORS 279C.560(5). Amounts retained will be included in the final payment made according to 00195.90.

Any retainage withheld on Work performed by a Subcontractor will be released to the Contractor according to 00195.50(d).

Modify the third paragraph from the following subsection as noted:

Add the following subsections as follows:

00195.90 Final Payment

- (d) The Contractor shall maintain a current and accurate record of the work completed during the course of this contract. These “as-built” drawings shall be kept by accurately marking a designated set of the contract Plans with the specified information as work proceeds. Accurate, complete and current “as-built” drawings are a specified requirement for full or partial payment of the work completed. At project completion and as a condition of final payment, the Contractor shall deliver an acceptably complete and legible full-size set of “as-built” drawings to Agency.

The “as-built” drawings must show the information listed below. Where the term “locate” or “location” is used, it means a record of position with respect to both the construction vertical datum and either horizontal datum or a nearby permanent improvement.

- Record location of underground services and utilities as installed.
 - Record location of existing underground utilities and services that are to remain and that are encountered during the course of the work.
 - Record changes in dimensions, location, grade or detail to that shown on the Plans.
 - Record changes made by change order.
 - Record details not in the original Plans.
 - Provide fully completed shop drawings reflecting all revisions.
- (e) Notwithstanding any contrary language in the Contract Documents, Contractor’s acceptance of the final payment will release Agency and the Engineer from all claims and all liability to the Contractor for all things done or furnished in connection with the Work, and every act of the Agency and others relating to or arising out of the Work. The Contractor’s acceptance of final payment is conclusive proof of Agency’s full performance under the Contract. If Agency requests, Contractor will sign a release stating Contractor has been paid in full prior to the final payment. No payment, final or otherwise, will operate to release the Contractor or the Contractor’s sureties from obligations under the Contract and will not affect the continuing validity and enforceability of the performance, payment and other bonds and warranties provided pursuant to the Contract.

SECTION 00196 – PAYMENT FOR EXTRA WORK

Comply with Section 00196 of the Standard Specifications.

SECTION 00197 – PAYMENT FOR FORCE ACCOUNT WORK

Comply with Section 00197 of the Standard Specifications.

SECTION 00199 – DISAGREEMENTS, PROTESTS, AND CLAIMS

Comply with Section 00199 of the Standard Specifications modified as follows:

Add the following text to the following subsection:

00199.20 Protest Procedure –

- (b) Written Notice** – The Engineer has no responsibility to evaluate the protest unless the Contractor has timely filed a proper notice submitting all of the above information. Failure to comply with this notice requirement renders the notice improper and shall constitute a waiver of any claim for additional compensation for any part of the protested work.

Delete the following subsection:

00199.20 Protest Procedure –

- ~~**(g) Protest Evaluation by Third Party Neutral**~~

Add the following subsection:

00199.30 Claims Procedure –

- (e) Payment of Costs, Expenses and Attorney’s Fees –**

Each party is responsible for its own costs, expenses and attorney’s fees in the event of litigation.

Add the following text to the following subsection:

00199.40(b) Step 1: Region Level Review

For the purposes of this Contract, the “Region-level reviewer” is Agency’s Public Works Director.

Modify the text of the following subsection as noted:

00199.40(c) Step 2: Agency Level Review

For the purposes of this Contract, the “Contract Administration Engineer” is the Agency’s City Manager.

If the Contractor does not accept the Step 2 decision, the Contractor may, within 10 Calendar Days of receipt of the written decision, request in writing through the Engineer that the claim be advanced to Step 3 or 4 (see (d) and (e) below), as applicable. ~~For purposes of determining which process to use for claims under Step 3 or 4 concerning a combination of additional compensation and Contract Time or for Contract Time only, the value of the claim or portion of the claim for Contract Time will be assumed to be the appropriate Liquidated Damages given in 00180.50 of the Special Provisions multiplied by the number of Calendar Days in question. If applicable, advancement of the claim is subject to the provisions of 00199.60 regarding waiver and dismissal of the claim or portions of the claim.~~

Remove the text from the following subsection and replace with the following:

~~**00199.40(d) Step 3: Arbitration; Claims Review Board**~~

00199.40(d) Step 3: Litigation – This step applies to any claim that is not resolved under Steps 1 or 2.

The Contractor must follow Steps 1 and 2 in order, and exhaust all available administrative remedies, before resorting to litigation. The Contractor must properly file a lawsuit in a court of competent jurisdiction within six months from the date of the final decision that exhausted the Contractor’s administrative remedies under this Contract.

In any litigation, the entire text of any order or permit issued by a governmental or regulatory body, as well as any documents referenced or incorporated by reference therein, will be admissible for the purpose of Contract interpretation.

The Contract or any of its provisions will not be construed against either party regardless of who drafted it. Other than as may be modified by the Contract, the applicable rules of contract construction and evidence will apply. The Contract will be governed by and construed in accordance with Oregon law without regard to conflict of laws principles.

Any dispute between the Agency and the Contractor that arises from or relates to the Contract and that is not resolved under Section 00199 may only be brought and must be conducted solely and exclusively in the Circuit Court for the State of Oregon, Washington County. If a dispute must be brought in a federal forum, then it may only be brought and conducted solely and exclusively in the United States District Court for the State of Oregon. To the maximum extent permitted by law, the dispute will be tried to a court without a jury and will not be subject to mandatory arbitration. In no event will this Subsection be construed as a waiver by the Agency of any form of defense or immunity, whether sovereign immunity, governmental immunity, immunity based on the Eleventh Amendment to the United States Constitution, from any claim or from the jurisdiction of any court. Contractor consents to the personal jurisdiction of the courts referenced herein.

In any dispute between the Agency and the Contractor that arises from or relates to the Contract, each party is solely responsible for its own costs and fees, including attorney fees.

Delete the following subsection in its entirety.

~~**00199.40(e) Step 4: Litigation**~~

Add the following subsection:

00199.55 Expenses, Costs and Attorney Fees – Notwithstanding any contrary language in the Contract Documents, each party will solely bear its own expenses, costs and fees, including attorney fees, throughout prosecution of the Work and including any disagreements, protests or claims, including all trials and appeals.

PART 00200 – TEMPORARY FEATURES AND APPURTENANCES

SECTION 00210 – MOBILIZATION

Comply with Section 00210 of the Standard Specifications modified as follows.

Add the following text to the following subsection:

00210.90 Payment –

Payment for Mobilization shall also include all labor, equipment, and material for work listed in the specifications and shown on the Contract Drawings that is not specifically listed with other items of the Bid Schedule.

SECTION 00220 – ACCOMMODATIONS FOR PUBLIC TRAFFIC

Comply with Section 00220 of the Standard Specifications modified as follows:

Modify and add the following bulleted items of the following subsection:

00220.02 Public Safety and Mobility

- Do not block driveways ~~for more than two hours~~ except as noted in the Contract Drawings unless otherwise authorized in writing.
- Do not stop or hold vehicles on any streets or driveways within the project site for more than 5 minutes.
- Do not install traffic control signs in a manner in which they will block an open bike lane or open walkway.
- Notify the City of Sherwood Police Department of all changes to the traffic control prior to implementing the change. Contact Corey Jentsch at JentschC@sherwoodoregon.gov (ph.503-925-7112) and traffic@TVFR.com.
- Notify the Tualatin Valley Fire & Rescue Department of all changes to the traffic control prior to implementing the change. Contact Amber Cross at amber.cross@tvfr.com (Ph. 503-259-1517).
- Notify the Sherwood School District of all changes to the traffic control prior to implementing the change. Contact Casey Jebens at cjebens@sherwood.k12.or.us (Ph. 503-692-9414).
- Notify the United States Post Office of all changes to the traffic control prior to implementing the change. Contact Patricia Becker at patricia.a.becker@USPS.gov.
- Notify Pride Disposal of all changes to the traffic control to occur on Fridays prior to implementing the change. Contact Kristen Tabscott at ktabscott@pridedisposal.com (Ph. 503-625-6177).

- Carbon copy City Project Managers at lams@sherwoodoregon.gov and christensenc@sherwoodoregon.gov and City Inspector stirlinga@sherwoodoregon.gov all traffic control notification emails.

Add the following bulleted items to the following subsection:

00220.40 General Requirements
(c) Driveways –

- Communicate with all affected property owners at least 48 hours in advance of any work which will affect access to the property.

Remove the text from the following subsection and replace with the following:

00220.40 General Requirements
(e) Lane Restrictions:
(1) Closed Lanes –

Traffic lanes may be closed on SW 2nd Street and SW Park Street when allowed, shown, or directed during the following periods of time except as specified in 0220.40(e)(2):

Single Lane/Parking Closures – One traffic lane and/or parking along SW 2nd Street and SW Park Street may be closed during the following times:

Monday through Friday between 7 a.m. and 7 p.m.

Contractor cannot close either street to through traffic. All parking and travel lanes must be reopened at the end of each shift. Two travel lanes of SW 2nd Street and SW Park Street must remain open at all times unless flaggers are provided.

- The contractor is responsible for the implementation of a traffic control plan and its continued functioning for the protection of construction workers, vehicular traffic, bicycle traffic, and pedestrians. All traffic control devices/signage shall be in accordance with the MUTCD. Approval of the traffic control plan by the City of Sherwood does not negate the contractor's responsibility to maintain a safe work zone. The City of Sherwood bears no liability for the contractor's implementation of a traffic control plan.
- The contractor is responsible for maintaining emergency vehicle access to all properties at all times.
- The contractor is responsible for maintaining access for mail and trash (Friday) and school bus services at all times.

SECTION 00221 – COMMON PROVISIONS FOR WORK ZONE TRAFFIC CONTROL

Comply with Section 00221 of the Standard Specifications modified as follows:

Add the following text to the following subsection:

00221.01(d) Field Adjustments to Traffic Control Plan –

If at any time during the work the Engineer or Inspector determines the Traffic Control Plan to be inadequate, the Contractor shall provide a revised Traffic Control Plan and install the additional signs and devices at no additional cost to the Owner.

Remove the text from the following subsection and replace with the following:

00221.10 General – Evaluate the condition of TCD using the criteria shown in the most current version in effect of the American Traffic Safety Services Association (ATSSA) publication titled “Manual on Uniform Traffic Control Devices for Streets and Highways”. Use new TCD or TCD meeting the "Acceptable" quality category of the ATSSA publication for all installations unless otherwise specified. Provide test results, quality compliance certificates, equipment lists, and drawings when specified. Acceptance will be by the QPL, test results, quality compliance certificates, equipment lists, drawings, and testing as necessary to assure compliance with the Specifications. After TCD have been installed and accepted on the Project, inspect and maintain the condition of the devices.

Add the following text to the following subsection:

00221.98 Payment, Method “B” – Lump Sum Basis –

Method “B” – Lump Sum Basis – shall be the payment method used for this project.

The Contractor shall be responsible for all traffic control costs including all flagging to complete the work and punch-list items.

Payment shall also include payment for the Contractor supplying approved traffic control plans as specified in the Provisions.

Any additional signs and devices deemed necessary by the Engineer or Inspector shall be installed at no additional cost to the Owner.

SECTION 00280 – EROSION AND SEDIMENT CONTROL

Comply with Section 00280 of the Standard Specifications modified as follows:

Add the following text to the following subsection:

00280.04 Erosion and Sediment Control Plan on Agency Controlled Lands

Do not begin any site activities that have potential to cause erosion or sediment movement until the erosion control facilities have been installed by contractor and approved by the City Inspector.

Update the ESCP and schedule as needed for unexpected storm or other events to ensure that sediment-laden water does not leave the construction site.

Add the following text to the following subsection:

00280.14 Erosion Prevention Materials –

(h) Facility Matting – Supply high density jute or coconut matting, meeting Clean Water Services (CWS) standards in locations designated on the plans.

Add the following text to the following subsection as noted:

00280.40 Installation –

Contractor to install erosion and sediment control BMP as shown and according to the most current edition of the ODOT Erosion and Sediment Control Manual. Install these BMP before performing clearing, grading, or other land alteration activities. Ensure that no visible and measurable sediment or pollutants leave the Project boundaries, enter drainage systems or waterways, or violate applicable water standards.

For purposes of this requirement, "visible and measurable" is defined as:

- Deposits or tracking of mud, dirt, sediment or similar material exceeding 1/2 cubic foot in volume on any private or public street or adjacent property, or into any storm or surface water drainage system, either by direct deposit, dropping or discharge, or as a result of erosion; or
- Evidence of concentrated flows of water over bare soils; turbid or sediment-laden flows; or evidence of on-site erosion, such as rivulets on bare slopes where the flow of water is not filtered or captured on the site; or
- Earth slides, mudflows, earth sloughing, or other earth movement off the Project site.

Modify the following text to the following subsection:

00280.90 – Payment

The accepted quantities of Work performed under this Section will be paid for at the Contract unit price, per unit of measurement, for the following items:

| Pay Item | Unit of Measurement |
|-------------------------------------|----------------------------|
| (a) Erosion Control, Complete | Lump Sum |

SECTION 00290 – ENVIRONMENTAL PROTECTION

Comply with Section 00290 of the Standard Specifications modified as follows:

Add the following text to the following subsection:

00290.10 Staging and Disposal Sites –

Any aggregate/soils contaminated by the contractor within the staging area or on the project

site shall be removed and replaced by the contractor at no additional cost.

Add the following subsection

00290.30(a) Pollution Control Measures

(7) Water Quality:

- Do not discharge contaminated or sediment-laden water, including drilling fluids and waste, or water contained within a work area isolation, directly into any waters of the State or U.S. until it has been satisfactorily treated (for example: bioswale, filter, settlement pond, pumping to vegetated upland location, bio-bags, dirt-bags). Treatment shall meet the turbidity requirements below.
- Do not cause turbidity in waters of the State or U.S. greater than 10% above background reading (up to 100 feet upstream of the Project), as measured 100 feet downstream of the Project.
- During construction, monitor in-stream turbidity and inspect all erosion controls daily during the rainy season and weekly during the dry season, or more often as necessary, to ensure the erosion controls are working adequately meeting treatment requirements.
- If construction discharge water is released using an outfall or diffuser port, do not exceed velocities more than 4 feet per second, and do not exceed an aperture size of 1 inch.
- If monitoring or inspection shows that the erosion and sediment controls are ineffective, mobilize work crews immediately to make repairs, install replacements, or install additional controls as necessary.
- Underwater blasting is not allowed.
- Implement containment measures adequate to prevent pollutants or construction and demolition materials, such as waste spoils, fuel or petroleum products, concrete cured less than 24 hours, concrete cure water, silt, welding slag and grindings, concrete saw cutting by-products and sandblasting abrasives, from entering waters of the state or U.S.
- End-dumping of riprap within the waters of the state or U.S. is not allowed. Place riprap from above the bank line.
- Cease project operations under high flow conditions that may result in inundation of the project area, except for efforts to avoid or minimize resource damage.
- The Project Manager retains the authority to temporarily halt or modify the Project in case of excessive turbidity or damage to natural resources.

Add the following text to the following subsection:

00290.32 Noise Control –

Review City of Sherwood Code of Ordinances, Chapter 9.52 which describes noise control regulations. Obtain and be responsible for necessary permits described in City of Sherwood Code of Ordinances, Chapter 9.52. Comply with the applicable noise control requirements for Project Work.

Add the following text to the following subsection:

00294.34 Protection of Fish and Fish Habitat –

Meet with the Agency, Engineer, and inspector on site, before moving equipment on-site or beginning any work, to ensure that all parties understand the locations of sensitive biological site and the measures that are required to be taken to protect them.

Add the following text to the following subsection:

00294.36(a) Migratory Birds –

Do not disturb migratory bird nesting habitat (shrubs, trees, and structures), or clear vegetation from March 1 to September 1 of each year without prior written approval from the Engineer. Notify the Engineer, in writing, a minimum of 10 Calendar Days prior to starting activities that could harm nesting birds.

Remove the text from the following subsection and replace with the following:

00290.90 Payment – There will be no payment for work performed under this Section.

PART 00300 – ROADWORK

SECTION 00305 – CONSTRUCTION SURVEY WORK

Comply with Section 00305 of the Standard Specifications supplemented and modified as follows:

Remove the text from the following subsection and replace with the following:

00305.00 Scope – Provide construction survey work according to the current edition on the date of Advertisement, of the ODOT "Construction Surveying Manual for Contractors" October 2025 Edition. This manual is available on the web at:

https://www.oregon.gov/ODOT/ETA/Documents_Geometronics/Construction-Survey-Manual-Contractors.pdf

A base AutoCAD will be made available to the contractor's surveyor that may be useable for construction staking.

Contractor shall measure location of all piping encountered during the project and mark on as-built to be supplied to the City.

Contractor shall have disturbed monuments reset by an Oregon Professional Land Surveyor, including any filing costs.

Add the following Section:

00305.10 Definitions –

“Construction Survey Work” – Surveying work necessary for the construction of the project. Includes cost of any resetting of monuments due to construction activities to perform all work as shown in the contract drawings. Contractor to notify City Project Manager of any property corners/monuments that are in conflict with the construction work. Contractor may not remove monuments without approval of City Project Manager. Includes post construction surveying work to provide as constructed data. This work shall include surveying all new manholes, catch basins and cleanouts for horizontal location, rim elevations and invert elevations.

Remove the text from the following subsection and replace with the following:

00305.80 Measurement – No measurement of quantities will be made for construction survey work.

Remove the text from the following subsection and replace with the following:

00305.90 Payment – The accepted quantities of performing construction survey work will be paid for at the Contract lump sum amount for the item “Construction Survey Work”.

Payment will be payment in full for furnishing all material, equipment, labor, and incidentals necessary to complete the work as specified.

No separate or additional payment will be made for preparing surveying documents including but not limited to office time, preparing and checking survey notes, cut sheets, and all other related preparation work.

Costs incurred as a result of survey errors will be borne by the Contractor. Such costs include price adjustments for failure to meet requirements of the construction specifications, repair or removal and replacement of deficient product, and over-run of material.

Costs incurred as a result of having to replace disturbed or removed reference stakes (traffic, kids, etc.) will be borne by the Contractor.

Progress payments will not be in excess of the reasonable value of the surveying work as estimated by the Engineer.

SECTION 00310 – REMOVAL OF STRUCTURES AND OBSTRUCTIONS

Comply with Section 00310 of the Standard Specifications supplemented and modified as follows:

Add the following text to the following subsection:

00310.00 Scope –

Removal of Structures and Obstructions shall include, but not be limited to removal or the removal and installation of items designated on the plans or encountered in the field that are not covered by other bid items including but not limited to:

- Removal of existing irrigation system.
- Removal of cut-off drain, including perforated pipe, cleanout, drainage geotextile, and backfill material.
- Plugging cut-off drain with mechanical plug.
- Removal of concrete flow spreader.
- Removal and reinstallation of chain link fence required to access the project site.
- Other miscellaneous structures or obstructions encountered in the field designated to be removed or relocated by the engineer.

Add the following Section:

00310.05 Definitions –

Removal of Riprap – This bid item includes removing riprap from the weir box to be hauled off site and cleaning out sediment and debris from the weir box.

Remove the text from the following subsection and replace with the following:

00310.44 Earthwork in Connection with Removal –

Excavation required to perform removal of structures and obstructions will be considered Incidental to the removal work.

Provide aggregate backfill and compaction for all holes or utility trenches, associated with work in this section, up to the existing asphalt surface. Compaction shall be in accordance with the details in the contract Drawings. Native backfill may be used in locations outside of the right-of-way and driving areas at the discretion of the Inspector. No separate payment will be made for this work.

Add the following bid item to the following subsection:

**00310.91 Lump Sum Payment –
Pay Item**

Unit of Measurement

(b) Removal of Riprap Lump Sum

SECTION 00320 – CLEARING AND GRUBBING

Comply with Section 00320 of the Standard Specifications supplemented and/or modified as follows:

Remove the text from the following subsection and replace with the following:

00320.01 Areas of Work – The limits of the clearing and grubbing are as follows:

- Clearing of brushes and trimming of trees required for mobilizing equipment.
- Removal of vegetation within storm facility.
- All areas necessary for completing the work as approved by the Engineer.

Add the following text to the following subsection:

00320.40(a) Clearing Trees and Other Vegetation –

Contractor may elect to use aquatic herbicide AquaMaster, or approved equivalent, to kill weeds without harming aquatic and terrestrial ecosystem for ease of clearing and grubbing within the storm facility. Contractor shall consider herbicide and clearing and grubbing operation timeline to ensure the project work (with the exception of planting) takes place during the dry season.

Delete the first paragraph of the following subsection and replace with the following:

00320.40(b)(4) Salvaging Vegetation and Natural Materials –

All trees/shrubs within the project vicinity are to be saved unless otherwise designated on the Contract Drawings or as designated by the Engineer.

Delete the second bulleted item and add the following text to the following subsection:

00320.40(c) Tree and Vegetation Trimming –

- Trim branches over street as necessary for construction work.

The City Inspector shall be notified prior to and approve any tree trimming by the Contractor that is necessary to complete the work. If any tree trimming is to occur, clean vertical cuts shall be made and sealed meeting the approval of the Inspector.

The cost of tree trimming is incidental.

Add the following text to the following subsection:

00320.80 Measurement –

Measurement of “Clearing and Grubbing” will be done on a Lump Sum basis.

Add the following text to the following subsection:

00320.90 Payment –

Payment of “Clearing and Grubbing” will be done on a Lump Sum basis.

SECTION 00330 – EARTHWORK

Comply with Section 00330 of the Standard Specifications supplemented and/or modified as follows:

Add the following text to the following subsection:

00330.02 Definitions –

Regrading of Storm Facility – The regrading includes grading, placement, and compaction of the stormwater facility material to meet profile grades by reusing existing facility material. This item includes excavating, stockpiling within the facility, transporting between upper and lower facilities, placement, and compaction within the project. This bid item also includes any unused facility material that will need to be removed off site as necessary to regrade the facility.

Add the following subsection:

00330.05 Staging Area –

Storage of vehicles, equipment and materials shall be at a location approved by the Inspector. The city bears no responsibility for any contractor vehicles, equipment or materials that are stolen or vandalized.

Add the following subsection:

00330.96 Lump Sum Basis Payment –

| Pay Item | Unit of Measurement |
|---------------------------------------|----------------------------|
| (a) Regrading of Storm Facility | Lump Sum |

SECTION 00350 – GEOSYNTHETIC INSTALLATION

Comply with Section 00350 of the Standard Specifications supplemented and/or modified as follows:

Add the following definition to the following subsection:

00350.01 Definitions –

Impermeable Liner – A 30 mil geosynthetic waterproof liner.

Basin Liner – Impermeable liner installed underneath riprap located at the start of the swale. Liners to be installed at the bottom and all sides surrounding the riprap basin. Liners to be attached to the walls as shown on the plans.

Swale Liner – Impermeable liner installed adjacent to the retaining walls. Liners to be installed at least 2 feet from the flat section of the swale and up the sides of the wall at least 6 inches above swale finished grade. Liners to be attached to the walls as shown on the plans.

Add the following Subsection:

00350.43 Impermeable Liner Installation – Install per manufacturer’s recommendation and plan details.

Modify the text of the following subsection as follows:

00350.90 Payment –

| Pay Item | Unit of Measurement |
|--|----------------------------|
| (g) 30 Mil Impermeable Liner – Swale | Square Yard |
| (h) 30 Mil Impermeable Liner – Basin | Lump sum |

Items (g) and (h) include all materials, labor, and equipment necessary to seal impermeable liners together per manufacturer’s recommendation, including but not limited to cleaning, priming, drying, etc and installed per contract drawings. Item also all material, labor, and equipment required to attach the liner to concrete.

SECTION 00390 – RIPRAP PROTECTION

Comply with Section 00390 of the Standard Specifications supplemented and/or modified as follows:

Modify the text of the following subsection as follows:

00390.90 Payment –

| Pay Item | Unit of Measurement |
|---------------------------------|----------------------------|
| (b) Loose Riprap, Class 50..... | Cubic Yard |

Item (b) includes removing and reusing existing riprap on site and/or imported riprap placed on site. Any areas damaged by riprap storage will be restored to match existing conditions at no cost to the City.

PART 00400 – DRAINAGE AND SEWERS

SECTION 00470 – MANHOLES, CATCH BASINS, AND INLETS

Comply with Section 00470 of the Standard Specifications supplemented and/or modified as follows:

Add the following Subsection:

00470.18 Utility Vault Lid – Precast utility vault lid with two 42” diameter access points per Oldcastle 816-7-T-42EE lid, or approved equivalent. Lid shall fit with existing weir box without modifications.

Modify the text of the following subsection as follows:

00405.90 Payment –

| Pay Item | Unit of Measurement |
|--|----------------------------|
| (l) Utility 8’x16’ Vault Lid | Lump Sum |
| (m) Crane Mobilization for Vault Lid | Lump Sum |

Item (l) will also include delivery and placement of the lid over the weir box for the vault lid and cast iron manhole frames and covers.

Item (m) includes crane mobilization to get the vault lid down to the facility. This also includes any clearing of trees, branches, and vegetation required for the crane to lift the vault lid.

SECTION 00490 – WORK ON EXISTING SEWERS AND STRUCTURES

Comply with Section 00490 of the Standard Specifications modified as follows:

Add the following descriptive term to the following subsection:

00490.01 Descriptive Terms:

SandSnout – Flat shaped water quality structure attached flush to the existing weir box wall. Size shall be 11” x 18” by BMP Inc., or approved equivalent.

Weir Box Retrofit – This work consists of any work, materials, and equipment necessary to retrofit the existing weir box. This includes constructing rebar connection to existing concrete structure to close off the existing weir and drilling holes into the weir box.

Add the following text to the following subsection:

00490.40 General –

If drainage field tile or storm laterals are encountered during construction, notify the Engineer and the Agency’s Project Manager. The intent will be to connect any functioning drain tile system or storm laterals to the storm system in an appropriate manner. Such connection must be noted on the as-built drawings and must be approved by the Engineer.

Modify text and add the following pay item to the following subsection:

00490.90 Payment –

| Pay Item | Unit of Measurement |
|----------------------------|----------------------------|
| (j) SandSnout | Each |
| (k) Weir Box Retrofit..... | Lump Sum |

Item (j) also includes delivery and all materials, equipment, and labor required to install the snouts to the weir box wall.

Item (k) also includes but is not limited to formwork, rebar, sealant, concrete, and all equipment and materials and labor required to construct the retrofit in compliance with the contract drawings.

PART 00600 – BASES

SECTION 00640 – AGGREGATE BASE AND SHOULDERS

Comply with Section 00640 of the Standard Specifications.

PART 00700 – WEARING SURFACES

SECTION 00759 – MISCELLANEOUS PORTLAND CEMENT CONCRETE STRUCTURES

Comply with Section 00759 of the Standard Specifications modified as follows:

Add the following text to the following subsection:

00759.60 Concrete Flow Spreader –

Construct concrete flow spreader per plans. Flow spreaders shall span the width of the existing storm facility (wall to wall or 16 feet).

Add the following Pay Items to the following subsection:

00759.90 Payment –

| Pay Item | Unit of Measurement |
|----------------------------------|----------------------------|
| (o) Concrete Flow Spreader | Each |

Item (o) includes all materials, equipment, and labor to construct the concrete flow spreader in compliance with the contract drawings.

No separate or additional payment will be made for:

- Aggregate base
- Rebar
- Earthwork
- Excavation

PART 01000 – RIGHT OF WAY DEVELOPMENT AND CONTROL

SECTION 01030 – SEEDING

Comply with Section 01030 of the Standard Specifications modified as follows:

Add the following text to the following subsection:

01030.13(f) Types of Seed Mixes –

Seed mixtures upslope from the water quality facility shall consist of the following mixture:

- 40% Dwarf Tall Fescue
- 30% Dwarf Perennial Rye
- 25% Creeping Red Fescue
- 5% Colonial Bent Grass

The application rate shall be 120 lbs/acre for this mixture.

Remove the text of the following subsection and replace with the following:

01030.80 Measurement – There will be no measurement of pay items under this section.

Remove the text of the following subsection and replace with the following:

01030.90 Payment –

No separate or additional payment will be made for seeding. All seeding is incidental to the project.

SECTION 01040 – PLANTING

Comply with Section 01040 of the Standard Specifications modified as follows:

Add the following definition to the following subsection:

01040.02 Definitions:

Temporary Irrigation System – a temporary irrigation system that is either hand-watering or a piped irrigation system. Piped irrigation systems shall be undergrounded in hardscaped areas and can be above ground in softscaped areas.

Add the following text to the following subsection:

01040.19(h)(18) Herbaceous Plants – Plant list per Clean Water Service’s Low Impact Development Approaches Handbook for Public Facility Plant List. Plants shall be ½ gallon container sized. Plant list includes:

- Slough Sedge
- Spreading Rush

Add the following subsection:

01040.24 Facility Matting – Facility matting shall be high density jute or coconut matting, meeting CWS standards.

Remove the text of the following subsection and replace with the following:

01040.40 General – Install jute matting before planting. Planting areas are within the existing stormwater facility. Plant shall be planted 1' on center spacing. Be responsible for layout for plant placement, subject to approval by the Agency before planting. The Agency will make only field measurements necessary to calculate and verify quantities for payment.

Remove the text of the following subsection and replace with the following:

01040.70 General –

The Contractor is responsible for the survival of all plant material until the end of the Plant Establishment Period of 2 calendar years. The Plant Establishment Period will begin once project has received Final Acceptance. The original planting is considered complete when all the plant material has been planted to the satisfaction of the Agency.

Establishment Period Work includes removing all plants that are dead, dying, or which do not meet Specifications, and replacing them with healthy plants. All plants in place after this replacement will be recognized as the original planting and will be subject to the establishment Specifications. Repair, restore, and replace all plantings that have been damaged by vehicles, vandalized, and stolen according to 00170.80. This item also includes watering plants and removing weeds and invasive plants.

Add the following text to the following subsection:

01040.71 Plant Care and Success Criteria –

The following watering frequencies are required:

All planting, water at a frequency of 1 inch per week between June 15 and October 15.

Unusual weather conditions (i.e. drought or lower than normal precipitation) may warrant extended irrigation needs. Contractor is responsible for watering or providing a temporary irrigation system. Contractor to submit irrigation plan for city review and approval.

Remove the text of the following subsection and replace with the following:

01040.72 Periodic Inspections –

Upon completion of the original planting, full payment will be made of the bid item for all plantings shown on plans. Payment for the amount of the Bid Price in the Bid Schedule or minimum price for Plant Establishment, 2-Year, \$6,000 Min., whichever is greater, will be withheld for the 2-year plant establishment period. If the bidder bids a unit price less than the price stated in the Pay Item Name, the minimum price as stated in the Pay Item Name will replace the bidder's unit price with the Bid Total being changed accordingly. Bids submitted with amounts lower than the minimum bid price will not disqualify the bid and the bid item price will be increased to the bid item minimum with the price difference being added to the total bid amount.

The bid item of Plant Establishment, 2-Year, \$6,000 Min. covers all disturbed areas of the project.

During the 2-year plant establishment (includes weed control), the Contractor will make bi-annual inspections jointly with the Agency at the following times:

- Spring, early May
- Fall, late September

During each plant establishment and weed control inspection, the Agency may determine, based upon the specified success criteria and invasive species coverage, that corrective work is required. If so, the Agency will provide the Contractor with a written notice of required corrective work sent by hand-delivery, email, or mail.

Upon completion and acceptance of the corrective work, the Contractor shall be paid one quarter of the amount of the Plant Establishment, 2-Year, \$6,000 Min. bid item.

Remove the text of the following subsection and replace with the following:

01040.80 Measurement –

Plant materials will be measured on a unit basis.

Jute matting will be measured on an area basis on the ground surface.

No measurement will be made for Plant Establishment, 2-Year, \$6,000 Min. and Temporary Irrigation System

Modify the following subsection as follows:

01040.90 Payment –

| Pay Item | Unit of Measurement |
|--|----------------------------|
| (g) Herbaceous Plant, ½-gal Container | Each |
| (h) Facility Matting | Square Yard |
| (i) Plant Establishment, 2-Year, \$6,000 Min. | Lump Sum |

Item (i) also includes weed/invasive control, bi-annual inspections, replacing damaged plantings and seeding, and removing all temporary irrigation at the end of the 2-year plant establishment period. Item (j) also includes all labor, equipment, and material for a temporary irrigation system whether it is hand-watering or a piped system. This includes watering truck, hose, piping, valves, fittings, backflow device, and all equipment required for a sufficient irrigation system. Cost of water and any meter connection to the City water system will be borne by the contractor.

PART 02000 – MATERIALS

SECTION 02001 – CONCRETE

Comply with Section 02001 of the Standard Specifications.

SECTION 02010 – PORTLAND CEMENT

Comply with Section 02010 of the Standard Specifications.

SECTION 02020 – WATER

Comply with Section 02020 of the Standard Specifications.

SECTION 02030 – SUPPLEMENTARY CEMENTITIOUS MATERIALS

Comply with Section 02030 of the Standard Specifications.

SECTION 02040 – CHEMICAL ADMIXTURES

Comply with Section 02040 of the Standard Specifications.

SECTION 02050 – CURING MATERIALS

Comply with Section 02050 of the Standard Specifications.

SECTION 02080 – GROUT

Comply with Section 02080 of the Standard Specification.

SECTION 02320 – GEOSYNTHETICS

Comply with Section 02320 of the Standard Specifications.

SECTION 02415 – PLASTIC PIPE

Comply with Section 02415 of the Standard Specifications.

SECTION 02440 – JOINT MATERIALS

Comply with Section 02440 of the Standard Specifications.

SECTION 02510 – REINFORCEMENT

Comply with Section 02510 of the Standard Specification.

SECTION 02560 – FASTENERS

Comply with Section 02560 of the Standard Specifications.

SECTION 02630 – BASE AGGREGATE

Comply with Section 02630 of the Standard Specifications.

SECTION 02690 – PCC AGGREGATES

Comply with Section 02690 of the Standard Specifications.

SECTION 03020 – EROSION MATERIALS

Comply with Section 03020 of the Standard Specifications.

Division Five
Supplemental Information

**2006 STORM FACILITY AS BUILT PLANS
FOR REFERENCE ONLY**

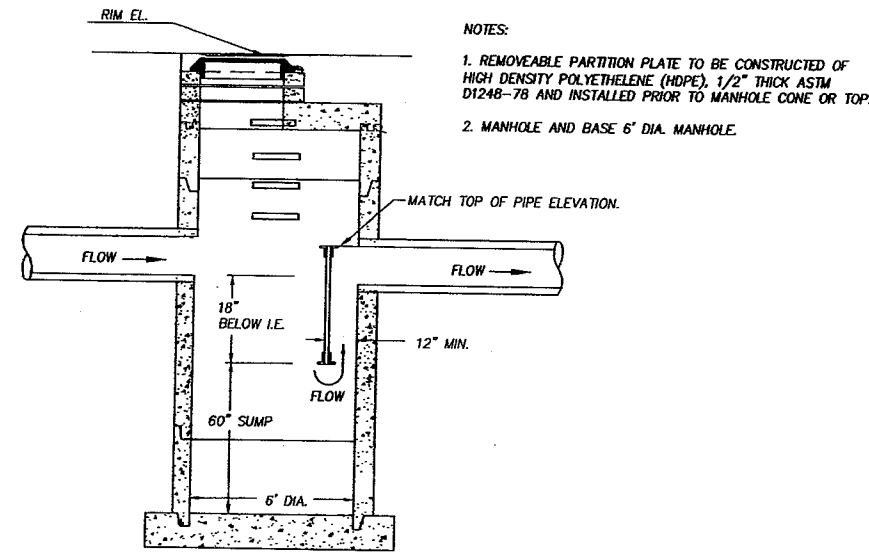
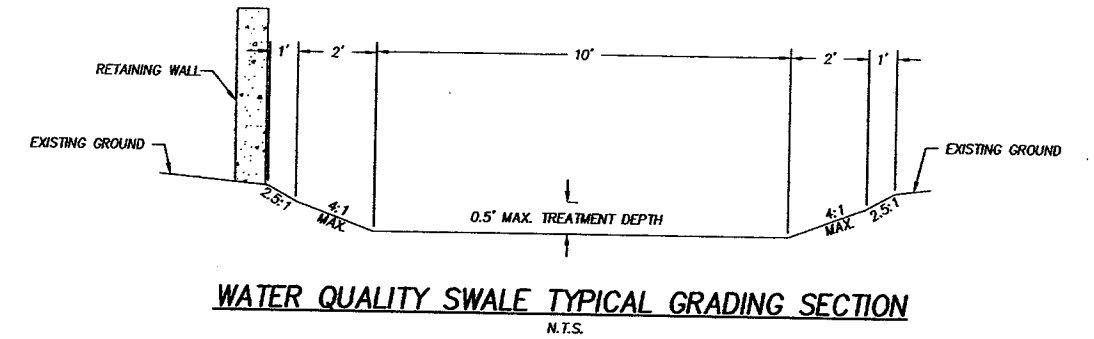
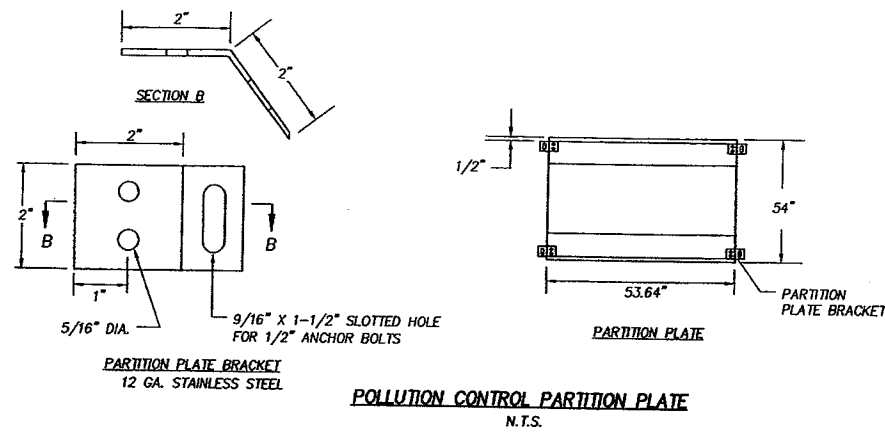

- NOTES:
1. REMOVABLE PARTITION PLATE TO BE CONSTRUCTED OF HIGH DENSITY POLYETHYLENE (HDPE), 1/2" THICK ASTM D1248-78 AND INSTALLED PRIOR TO MANHOLE CONE OR TOP.
 2. MANHOLE AND BASE 6" DIA. MANHOLE.

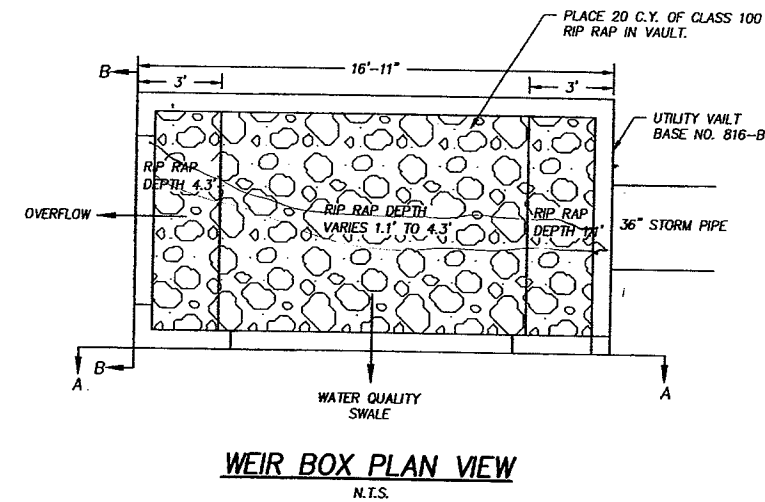
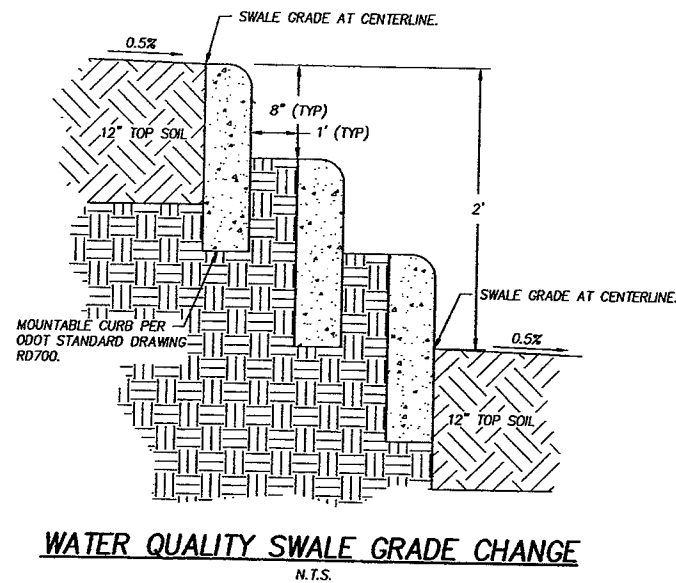
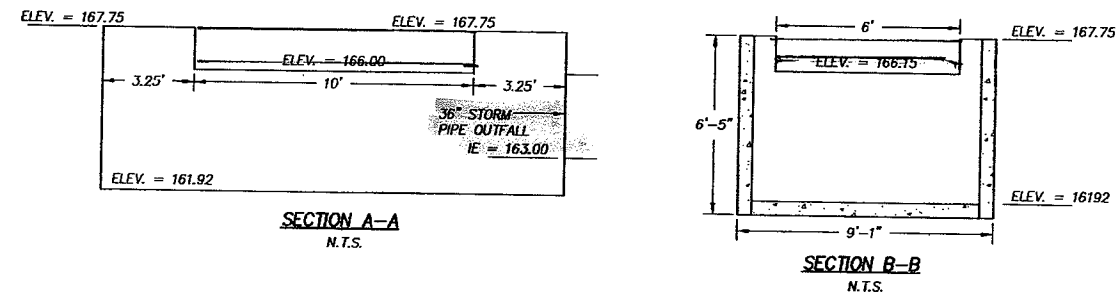

| Sheet Revisions | |
|-----------------|-----|
| U | /// |
| R-1 | /// |
| R-2 | /// |
| R-3 | /// |
| R-4 | /// |

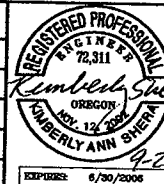

Sherwood Downtown Streetscape Improvements-Phase A
Engineering Department
15527 S. W. Willamette St.
Sherwood, OR 97140
Phone: (503) 925-2305
FAX: (503) 625-0679

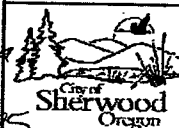

**Harper
Houf Peterson
Righellis Inc.**
ENGINEERS • PLANNERS • SURVEYORS
5200 SW MACADAM AVENUE, SUITE 580, PORTLAND, OR 97239
TEL 503.221.1131 www.hhpr.com FAX 503.221.1171

| | |
|----------------|-----|
| As Constructed | /// |
| No Revisions: | /// |
| Revised: | /// |
| Void: | /// |

| WATER QUALITY DETAILS | |
|-----------------------|-------------------|
| Designer: | Structure Numbers |
| Detailer: | Sheet Subset: |
| Sheet Subset: | Subset Sheets: |

| | |
|------------------------|------------|
| Project No./Code | 071668.100 |
| City of Sherwood CIP # | #-41 |
| Sheet Number | D15 |

FOR REFERENCE ONLY

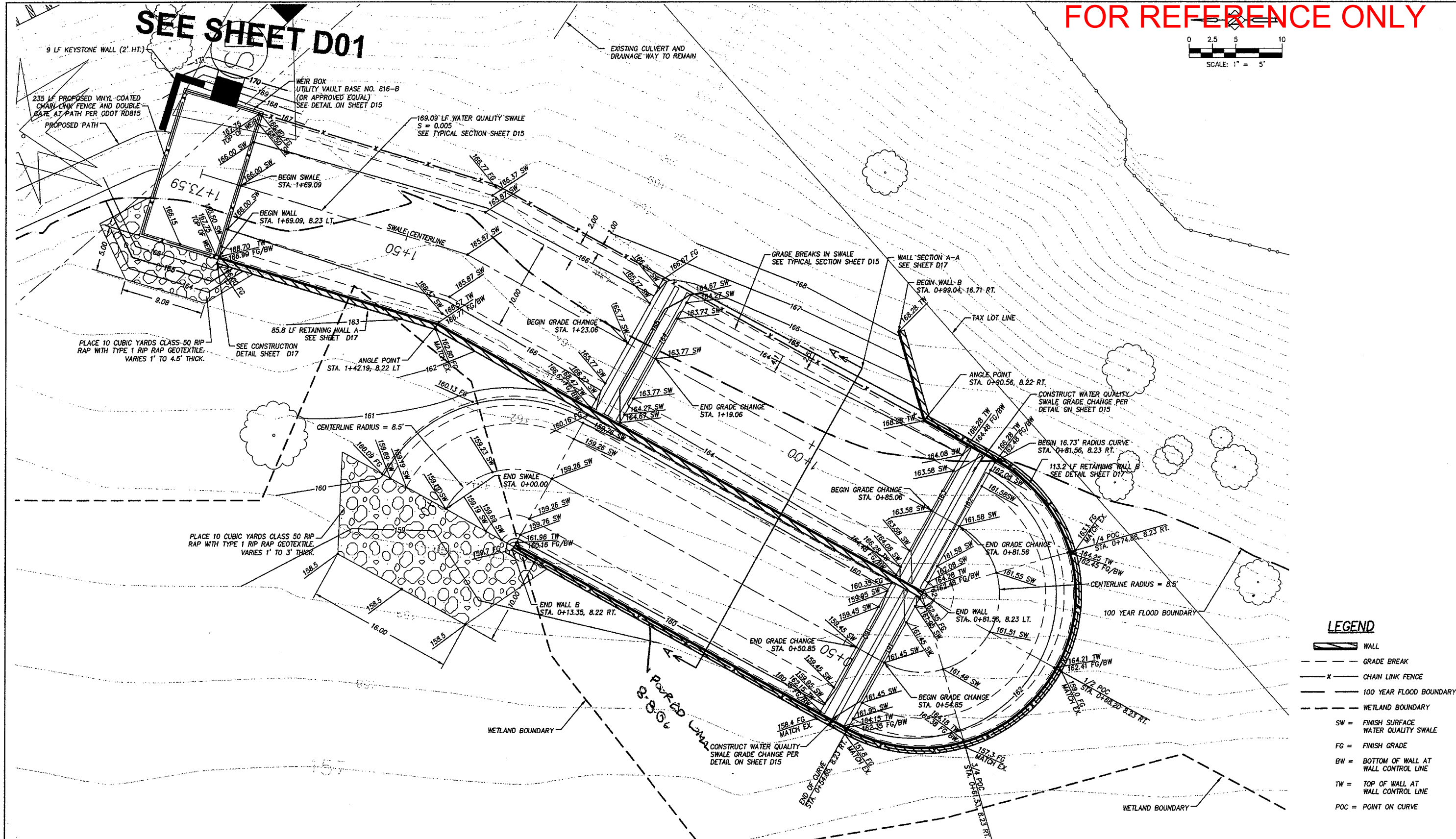

LEGEND

- WALL
- GRADE BREAK
- CHAIN LINK FENCE
- 100 YEAR FLOOD BOUNDARY
- WETLAND BOUNDARY
- SW = FINISH SURFACE WATER QUALITY SWALE
- FG = FINISH GRADE
- BW = BOTTOM OF WALL AT WALL CONTROL LINE
- TW = TOP OF WALL AT WALL CONTROL LINE
- POC = POINT ON CURVE

| Sheet Revisions | |
|-----------------|---------------------|
| (R-1) | 7/22/05 ADDENDUM #2 |
| (R-2) | / / |
| (R-3) | / / |
| (R-4) | / / |
| (R-5) | / / |

SHERWOOD DOWNTOWN STREETSCOPE IMPROVEMENTS—PHASE A

Kimberly Ann Biehler
REGISTERED PROFESSIONAL ENGINEER
NO. 72,811
STATE OF OREGON
EXPIRES: 6/30/2006

City of Sherwood
Engineering Department
15527 S. W. Willamette St.
Sherwood, OR 97140
Phone: (503) 925-2305
FAX: (503) 625-0679

Harper Houf Peterson Righellis Inc.
ENGINEERS • PLANNERS • SURVEYORS
5200 SW MACADAM AVENUE, SUITE 500, PORTLAND, OR 97239
TEL. 503.221.1131 www.hhpr.com FAX 503.221.1171

| As Constructed | |
|----------------|-----|
| No Revisions: | / / |
| Revised: | / / |
| Void: | / / |

| WATER QUALITY SWALE | |
|---------------------|-------------------|
| Designer: | Structure Numbers |
| Detailer: | |
| Sheet Subset: | Subset Sheets: |

| Project No./Code | |
|---------------------------|-----|
| 071668.100 | |
| City of Sherwood CIP #—41 | |
| Sheet Number | D16 |

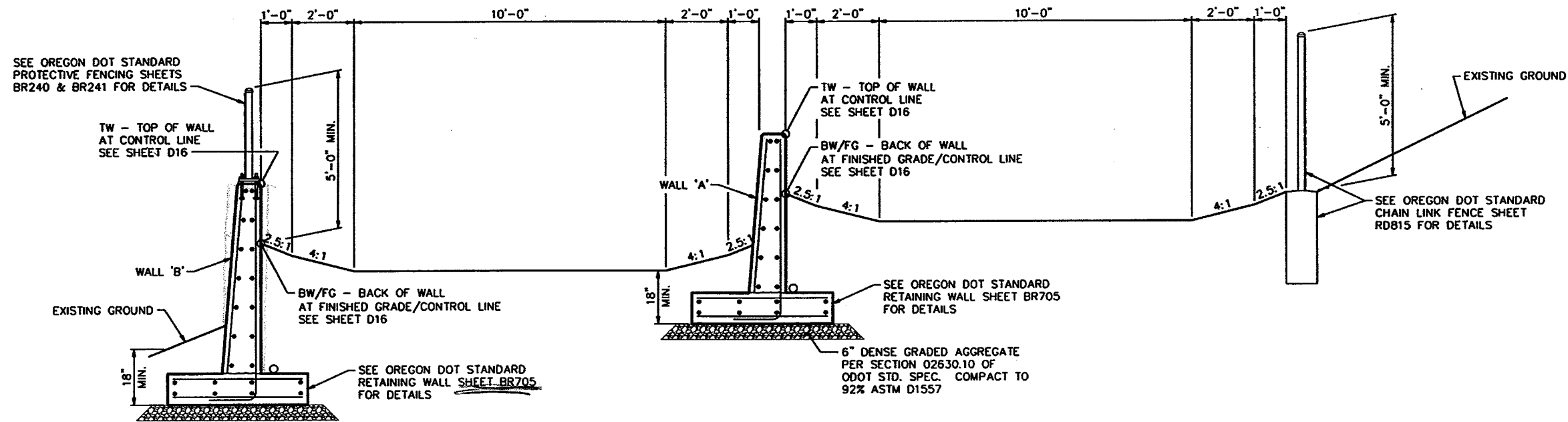

WALL SECTION A-A
(LOOKING NORTH)

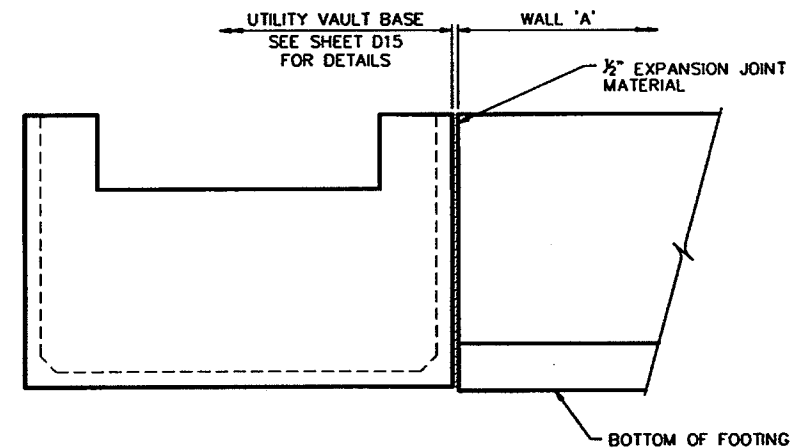

ELEVATION
NORTH END OF WALL A

| | | | | | | | | | | | | | |
|----------------------------------|----------------------------|------------------------|--------------|--|---------|---|--|-------------------------------------|-----|-------------------------|---------|----------------|----------------------------|
| Computer File Information | | Sheet Revisions | | Sherwood Downtown Streetscape Improvements-Phase A | | As Constructed | | PARK STREET-WQF WALL SECTION | | Project No./Code | | | |
| Creation Date: | 02/23/05 | Initials: | DMB | (R-) | / / | Engineering Department 15527 S. W. Wilamette St. Sherwood, OR 97140 Phone: (503) 925-2305 FAX: (503) 625-0679 | CarterBurgess 707 17th St., Suite 2300 Denver, CO 80202 Phone: (303) 820-5240 FAX: (303) 820-2402 | No Revisions: | / / | 071668.100 | | | |
| Last Modification Date: | 07/06/05 | Initials: | BDC | (R-) | / / | | | Revised: | / / | Designer: | Ruth | Structure | City of Sherwood CIP #C-41 |
| Path: | ...071668.100\CAD\STR\SHI\ | | | (R-) | / / | | | Void: | / / | Detailer: | Collins | Numbers | Sheet Number |
| Drawing File Name: | WQF WALL SECTION.DWG | | | (R-) | / / | | | | | Sheet Subset: | | Subset Sheets: | D17 |
| Acad Ver. | N.63.0 | Scale: | 1/4" = 1'-0" | Units: | English | | | | | | | | |

CONSTRUCTION NOTES

- ① REMOVE EXIST RIP-RAP AND EXIST SEDIMENT W/IN EXIST WEIR BOX - 20 CY, FURNISH & INSTALL: RIP-RAP (CLASS 100) - 20 CY, SEE SHT WQ-2 FOR DETS
- ② REMOVE AND REINSTALL EXIST SEGMENTAL RETAINING WALL - 26 LF, SEE SHT WQ-4 FOR DETS
- ③ MAINTAIN AND PROTECT EXIST 60" SDMH, LEAK TEST EXIST SDMH AND REPAIR LEAKS W/ NON-SHRINK GROUT OR BY AN APPROVED METHOD
- ④ CONST RIP-RAP (CLASS 50), TRANSITION FROM 1:4 SIDE SLP TO 0 AT EXIST GRADE CHANGE CURB - 0.12 CY EA LOCATION
- ⑤ CONST CUT-OFF DRAIN - 17 LF, SEE SHT WQ-3 FOR DETS
- ⑥ FURNISH AND INSTALL TEMPORARY DAM ACROSS WATER QUALITY WEIR ON THE EXISTING WEIR BOX DURING CONSTRUCTION, REMOVE TEMPORARY DAM ONCE EROSION CONTROL MATTING IS PLACED OR AS APPROVED
- ⑦ REMOVE EXIST TOPSOIL (12" DEPTH) AND EXIST TREES, REGRADE EXIST SWALE, FURNISH & INSTALL: COMPOST AMENDED TOPSOIL (12" DEPTH), SEE SHT WQ-2 FOR DETS, MATCH EXIST PROFILE GRADE
- ⑧ REGRADE EXIST RIP-RAP AT SWALE MATCH POINT AS NECESSARY
- ⑨ CONST RIP-RAP (CLASS 50) OUTFALL PROTECTION - 0.20 CY, EA LOCATION
- ⑩ CONST FLOW SPREADER, SEE SHT WQ-3 FOR DETS
- ⑪ LOCATE (3) EXIST 1/2" WEEP HOLES AT BOTTOM OF EXIST WEIR BOX AND UNPLUG AS NECESSARY
- ⑫ MAJOR ADJUSTMENT OF EXIST 72" DIA MH, SEE SHT WQ-5 FOR DETS
- ⑬ SAW CUT EXIST PAVEMENT, AND TRENCH RESURFACING TO MATCH ADJACENT PAVEMENT SECTION, SEE COS STD DRAWINGS ON SHT WQ-7
- ⑭ N624663.89, E7599618.26, FURNISH & INSTALL: 1-60" DIA SEDIMENTATION MH, SEE SHT WQ-6 FOR DETS
- ⑮ FURNISH & INSTALL: 4 LF 10" PVC C900 SD (EA WAY) BETWEEN MANHOLES, (APPROX 2 LF BETWEEN OUTSIDE WALLS)

SHEET NOTES:

1. SEE EROSION CONTROL SHEETS FOR TEMPORARY PROTECTION AND ACCESS.
3. COORDINATE LAYOUT WITH ENGINEER PRIOR TO CONSTRUCTION.
4. CONSTRUCTION ACCESS SHALL BE LIMITED TO THE EXISTING STELLA OLSEN TRAIL HEAD LOCATED AT SW 2ND STREET AND SW PARK STREET.
5. CONTRACTOR TO SUBMIT TRAFFIC CONTROL PLAN FOR APPROVAL OF TRAIL AND STREET CLOSURES AS NECESSARY.
6. SEE EROSION AND SEDIMENT CONTROL SHEETS FOR EROSION CONTROL REQUIREMENTS.

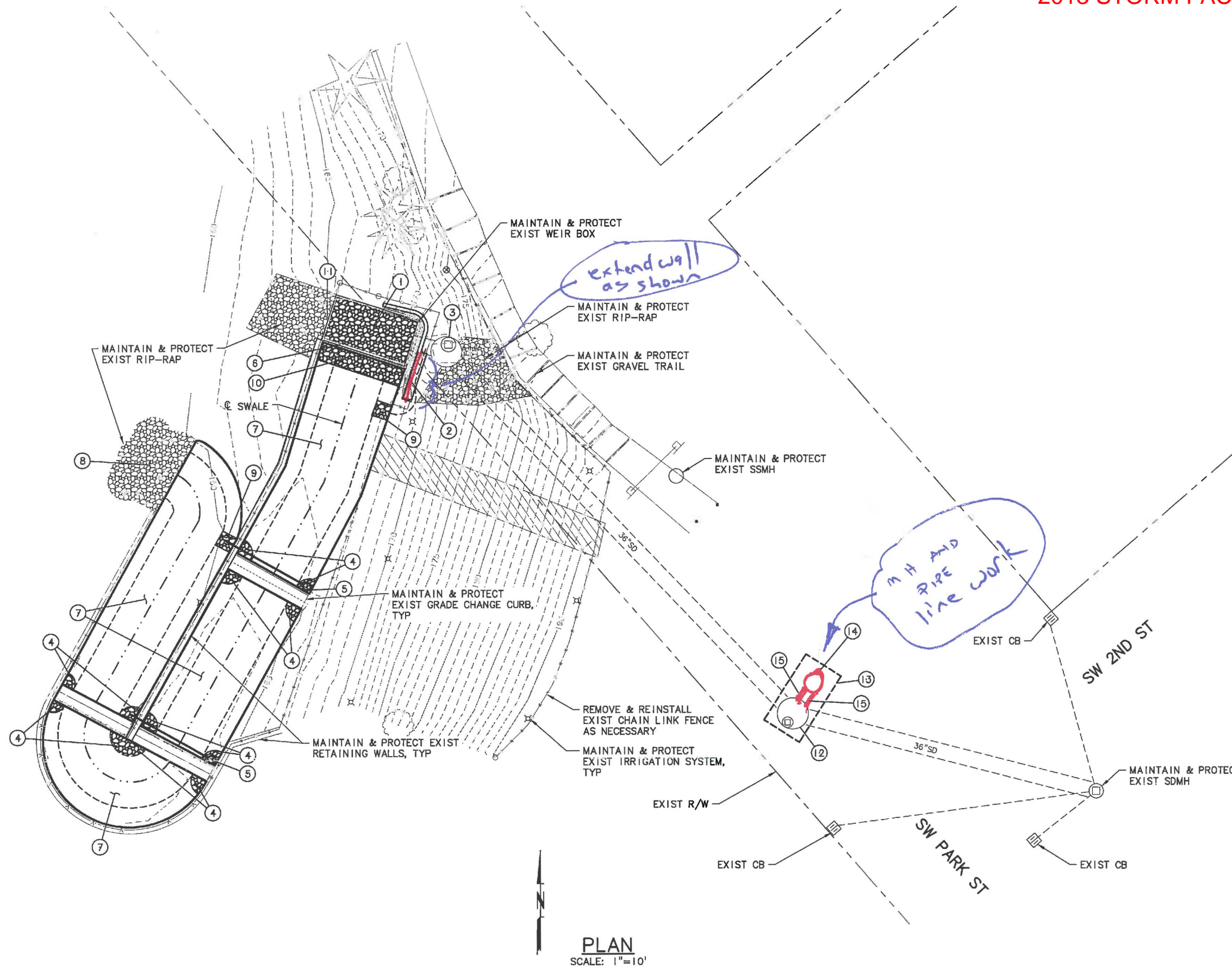

PLAN
SCALE: 1"=10'

CONSTRUCTION NOTES FOR REFERENCE ONLY

G:\PDX_Projects\12\1319\OR-WQ-R.dwg WQ-1 6/28/2013 4:45 PM RLF 18.2s (LMS_Tech)

| NO. | DATE | BY | REVISION |
|-----|----------|-----|----------------|
| 1 | 07/12/13 | AHG | RECORD DRAWING |

NOTICE

0 1/2 1

IF THIS BAR DOES NOT MEASURE 1" THEN DRAWING IS NOT TO SCALE

AHG
DESIGNED
RLF
DRAWN
GEC
CHECKED

RECORD DRAWING

SEE DISCLAIMER, SHEET 1.

VERSION 4.1
12-9-97

MSA Murray, Smith & Associates, Inc.
Engineers/Planners

121 S.W. Salmon, Suite 900 PHONE 503-225-9010
Portland, Oregon 97204 FAX 503-225-9022



DOWNTOWN STREETScape PHASE 2 IMPROVEMENTS

WATER QUALITY FACILITY MAINTENANCE PLAN

PROJECT NO.: 12-1319.1201 SCALE: AS SHOWN DATE: NOVEMBER 2012

SHEET
WQ-1
42 of 78

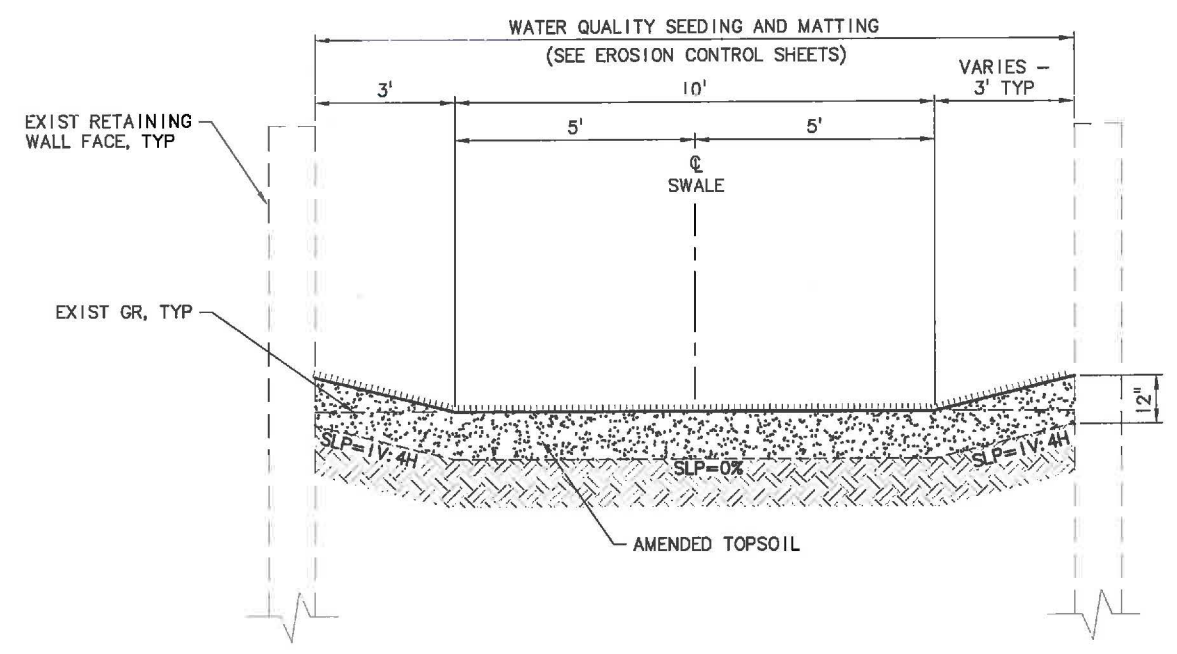

TYPICAL SECTION - WATER QUALITY SWALE
SCALE: NTS

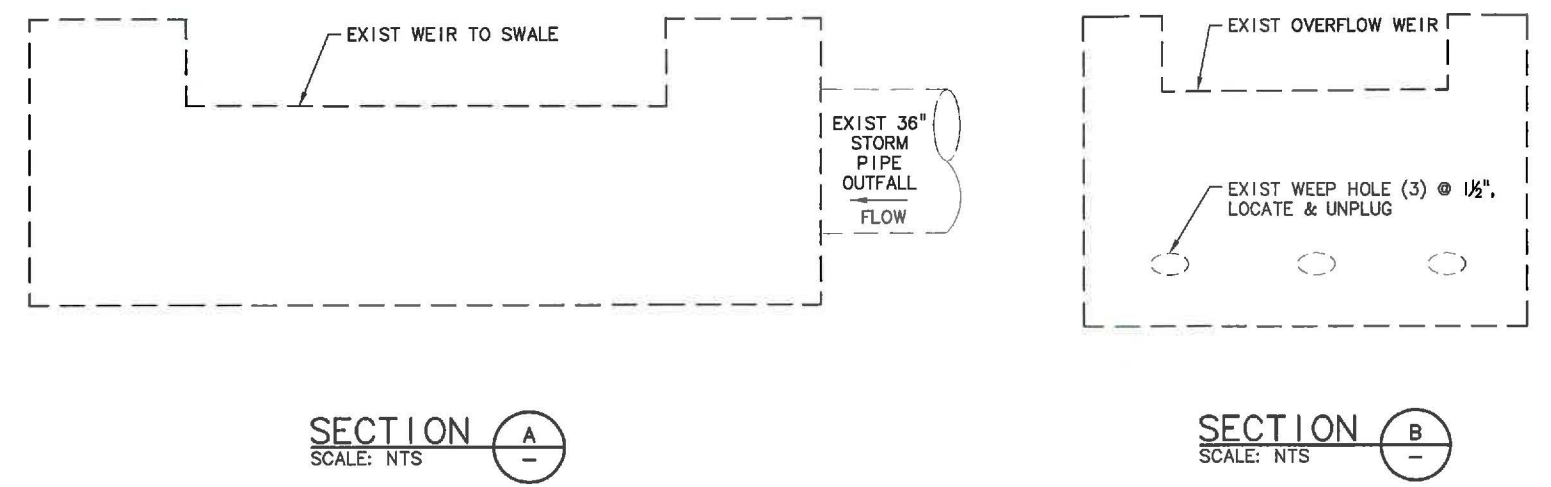
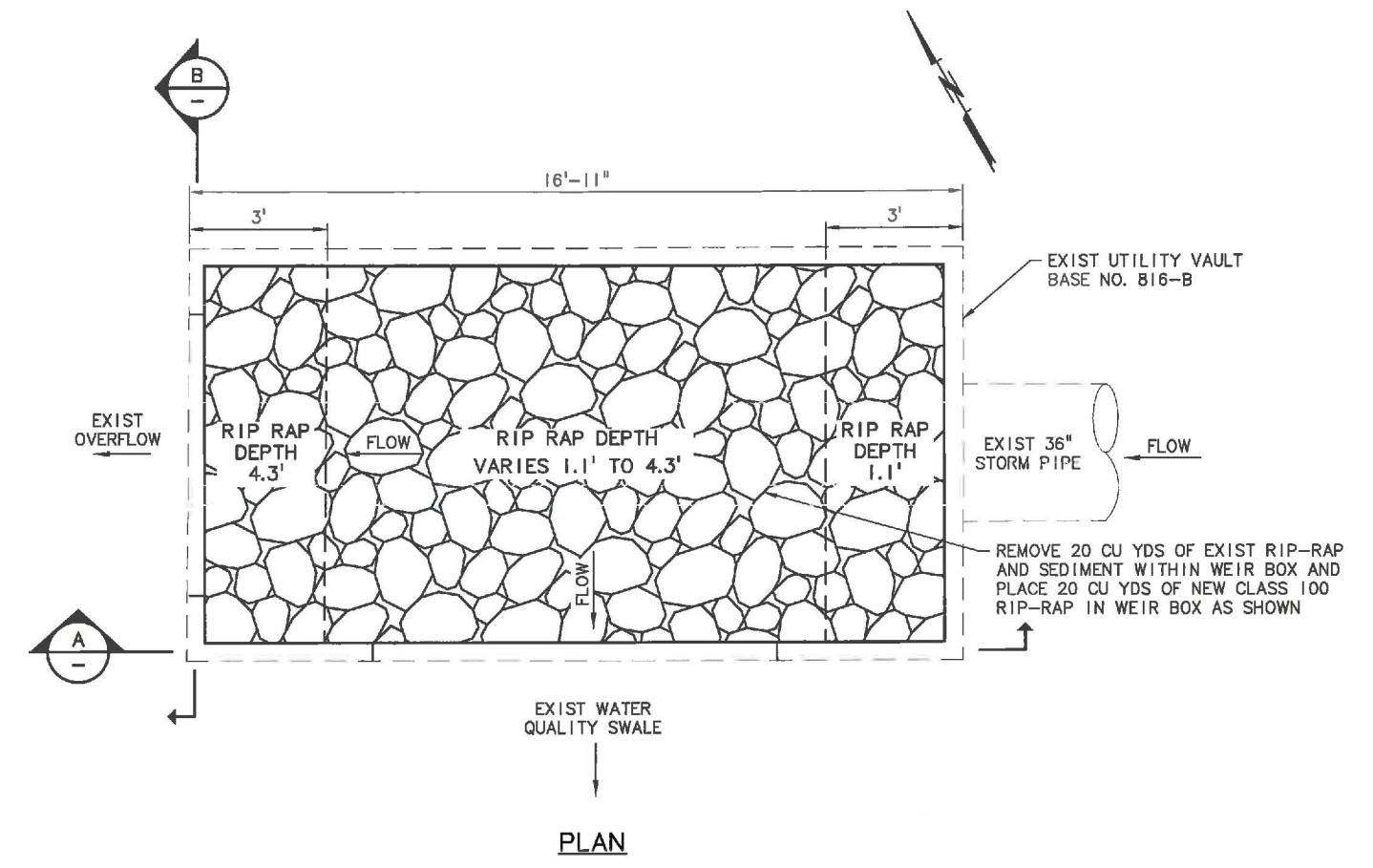

SECTION A
SCALE: NTS

SECTION B
SCALE: NTS

EXISTING WEIR BOX MODIFICATION
SCALE: NTS

CONSTRUCTION NOTES FOR REFERENCE ONLY

G:\PDX_Project\12\1319\CAD\DWG\SHEETS\WATER_QUALITY\12-1319-OR-WQ-R.dwg WQ-2 6/28/20 3:45 PM RLF 18.2s (LMS Tech)

| NO. | DATE | BY | REVISION |
|-----|----------|-----|----------------|
| 1 | 07/12/13 | AHG | RECORD DRAWING |

NOTICE
0 1/2 1
IF THIS BAR DOES NOT MEASURE 1" THEN DRAWING IS NOT TO SCALE

AHG
DESIGNED
RLF
DRAWN
GEC
CHECKED

RECORD DRAWING
SEE DISCLAIMER, SHEET 1.
VERSION 4.1
12-9-97

MSA Murray, Smith & Associates, Inc.
Engineers/Planners
121 S.W. Salmon, Suite 900 PHOEN 503-225-9010
Portland, Oregon 97204 FAX 503-225-9022

City of Sherwood Oregon

DOWNTOWN STREETSCAPE PHASE 2 IMPROVEMENTS

WATER QUALITY FACILITY SWALE MAINTENANCE DETAILS - 1

PROJECT NO.: 12-1319.1201 SCALE: AS SHOWN DATE: NOVEMBER 2012

SHEET
WQ-2
43 of 78

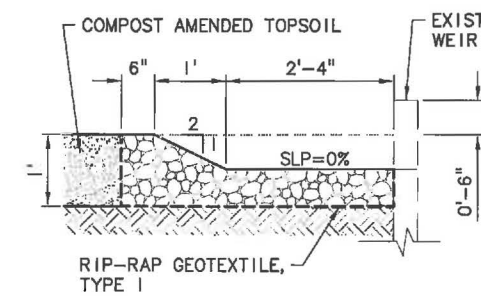
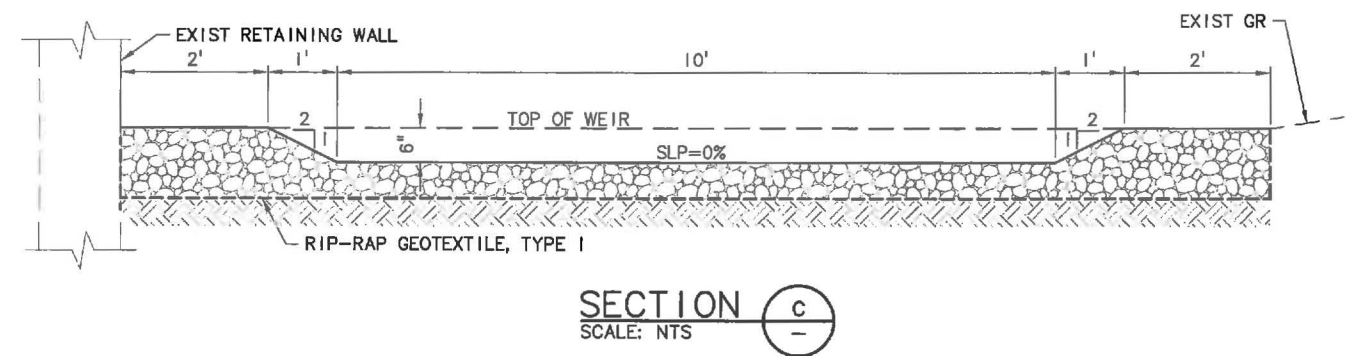
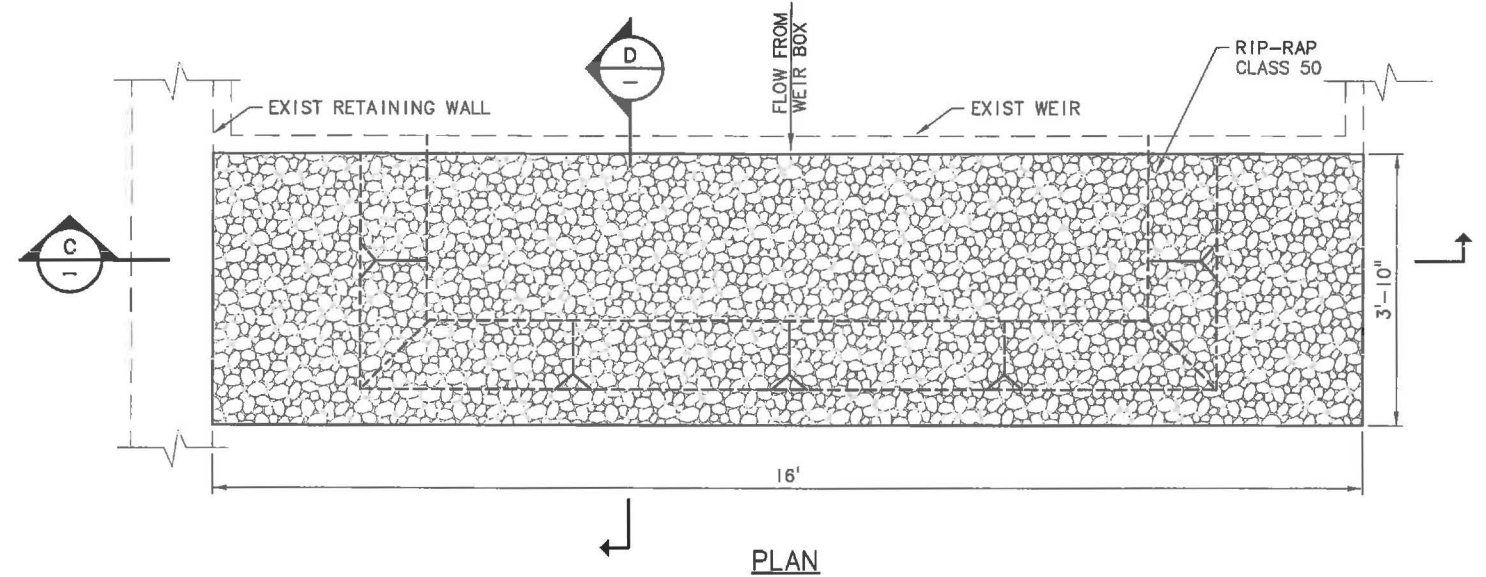
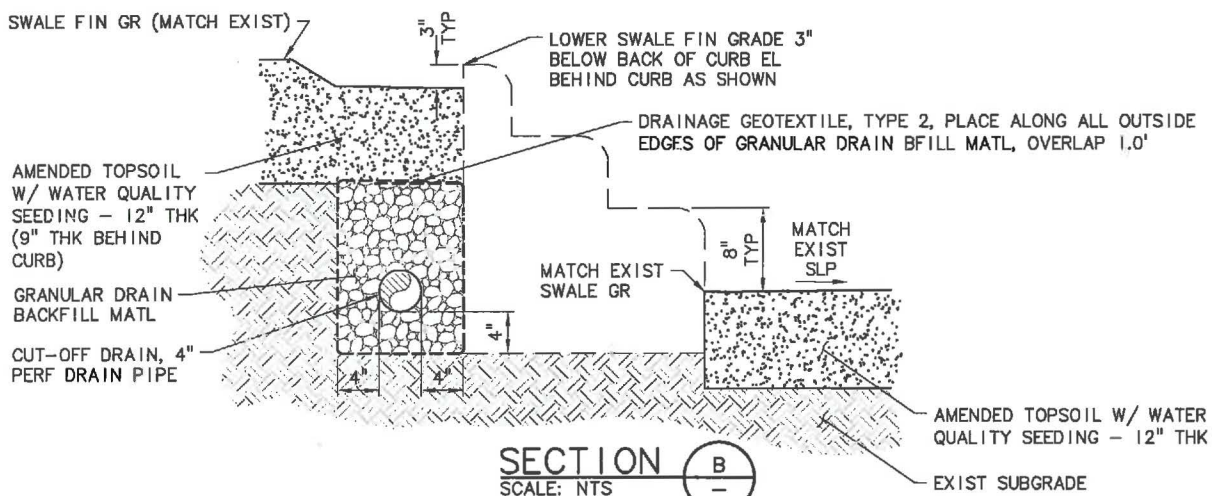
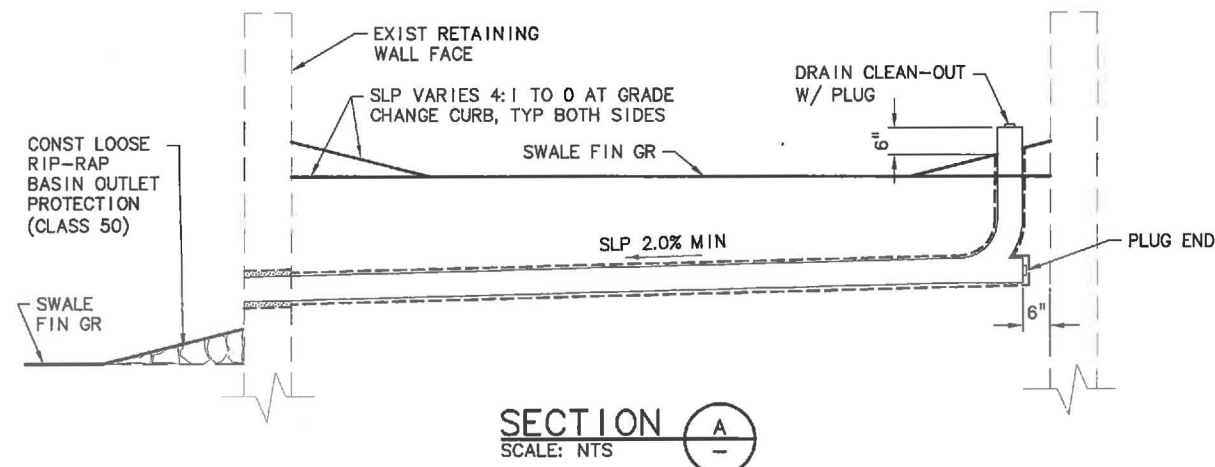
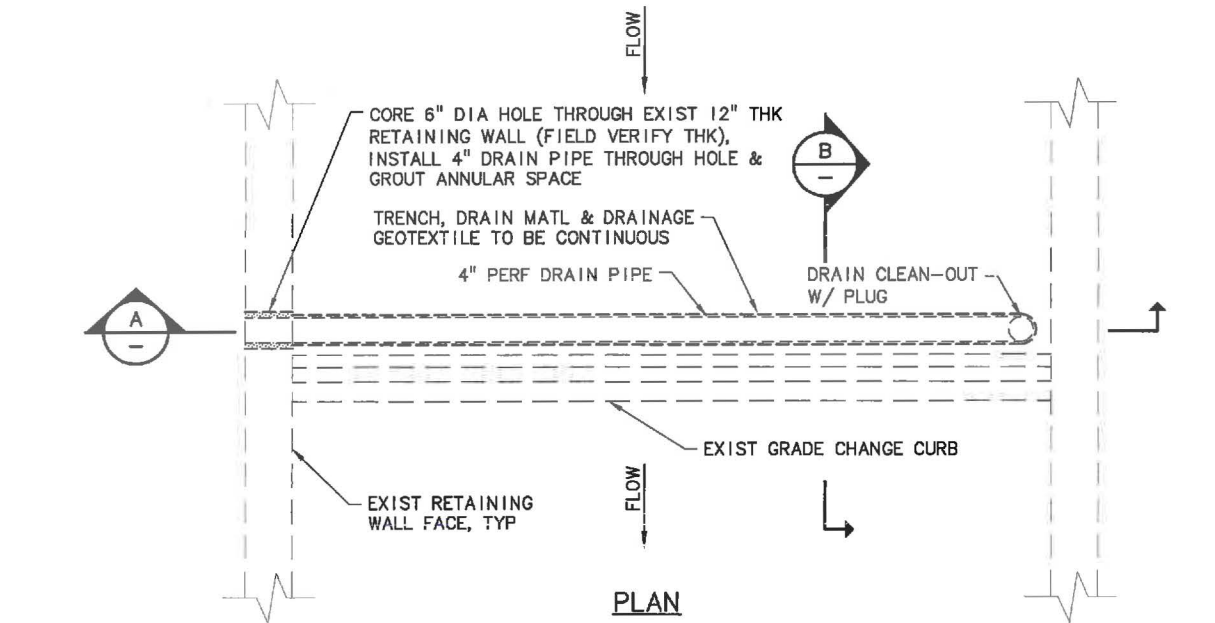

G:\PDX_Projects\12-1319\CD\DR\SHEETS\WATER QUALITY\12-1319-OR-WQ-R.dwg WO-3 6/28/2013 4:45 PM RLF 18.2s (LWS Tech)

CONSTRUCTION NOTES FOR REFERENCE ONLY

| NO. | DATE | BY | REVISION |
|-----|----------|-----|---------------------------------|
| Δ | 07/12/13 | AHG | RECORD DRAWING |
| Δ | 12/12/12 | RER | ADD #1: DETAIL SECTION REVISION |

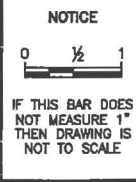

AHG
DESIGNED
RLF
DRAWN
GEC
CHECKED

RECORD DRAWING
SEE DISCLAIMER, SHEET 1.
VERSION 4.1
12-9-97

MSA Murray, Smith & Associates, Inc.
Engineers/Planners
121 S.W. Salmon, Suite 900 PHONE 503-225-9010
Portland, Oregon 97204 FAX 503-225-9022



DOWNTOWN STREETScape PHASE 2 IMPROVEMENTS

WATER QUALITY FACILITY SWALE MAINTENANCE DETAILS - 2

PROJECT NO.: 12-1319.1201 SCALE: AS SHOWN DATE: NOVEMBER 2012

SHEET
WQ-3
44 of 78

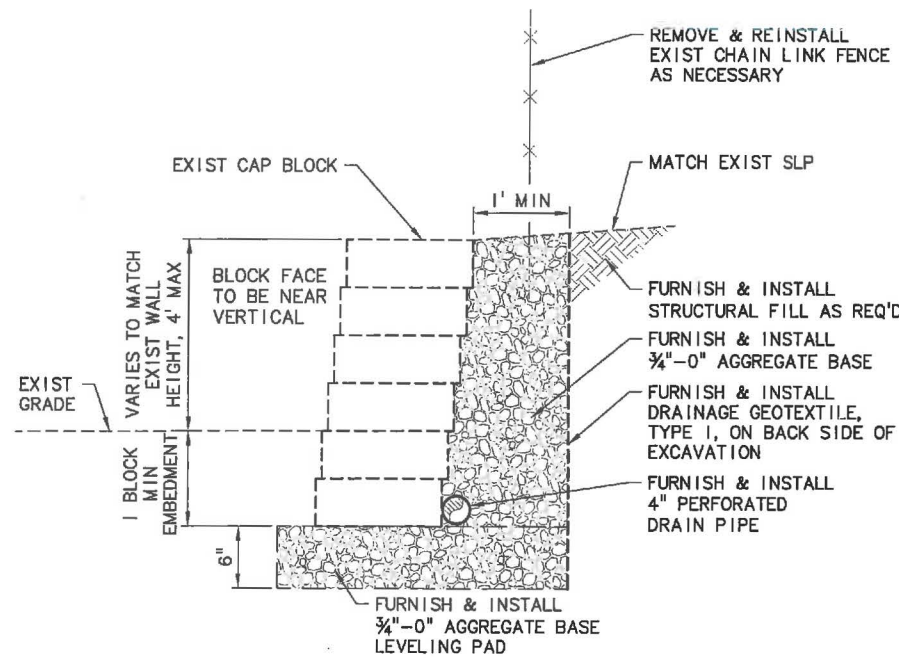

TYPICAL EXISTING RETAINING WALL SECTION (1)
SCALE: NTS

- NOTES:**
1. REMOVE APPROXIMATELY 26 LINEAR FEET OF EXISTING SEGMENTAL RETAINING WALL. VERIFY LIMITS WITH ENGINEER.
 2. REMOVE EXISTING WALL BACKFILL AND SAVE BLOCKS.
 3. INSTALL NEW DRAIN PIPE AND BACKFILL MATERIAL AND REINSTALL WALL BLOCKS TO ORIGINAL LINES AND GRADES.
 4. DAYLIGHT 4" PERFORATED DRAIN PIPE AT DOWNHILL SIDE OF WALL. INSTALL OUTLET PROTECTION BLOCK. SEE DETAIL, THIS SHEET. INSTALL RIP-RAP OUTLET PROTECTION AROUND OUTLET BLOCK PER SHEET WQ-1.
 5. SECURE CAP UNITS TO STANDARD UNITS USING KAPSEAL ADHESIVE OR APPROVED EQUAL.

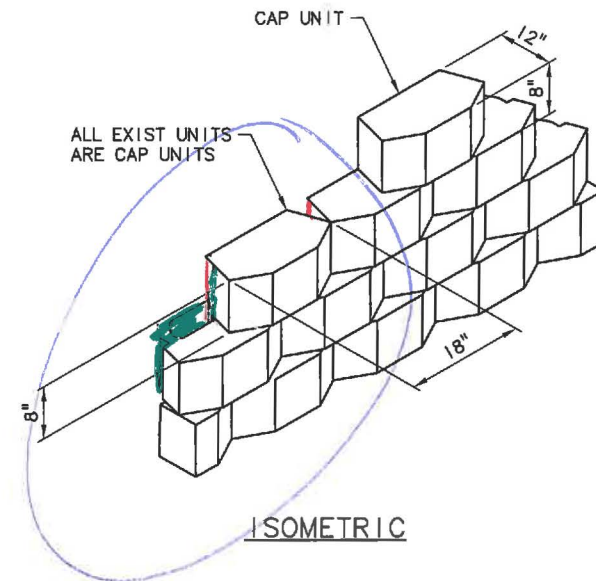

TYPICAL RETAINING WALL LAYOUT (2)
SCALE: NTS

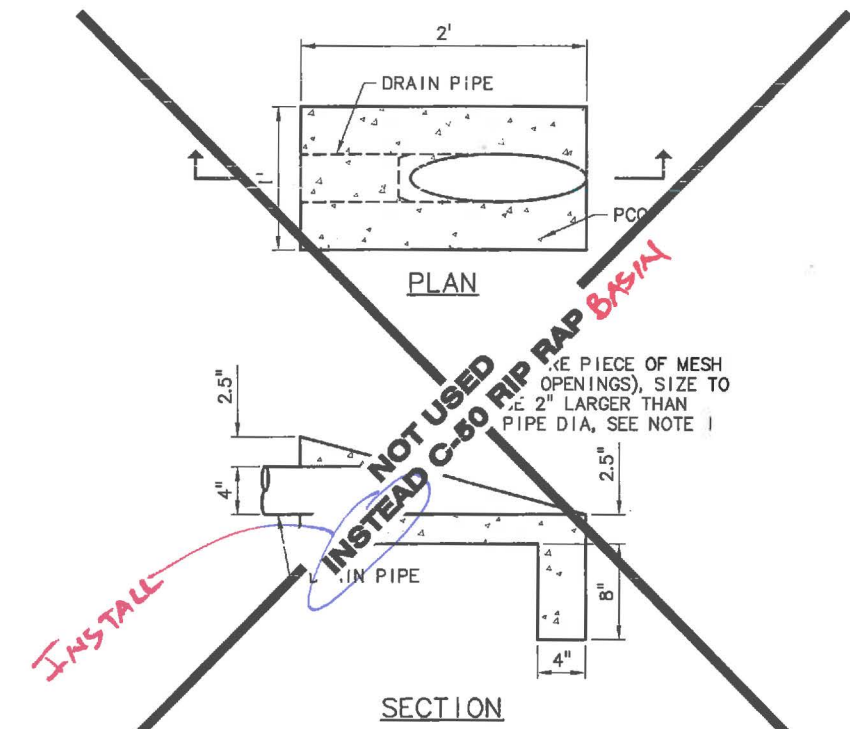

OUTLET PROTECTION BLOCK (3)
SCALE: NTS

- NOTES:**
1. MESH FOR RODENT CONTROL TO BE GALVANIZED WIRE OR APPROVED EQUAL.

INSTALL
NOT USED
INSTEAD C-60 RIP RAP BASIN

CONSTRUCTION NOTES FOR REFERENCE ONLY

G:\PDX_Projects\12\1319\CAD\DR\SHEETS\WATER QUALITY\12-1319-OR-WQ-4 6/28/2013 4:45 PM RLF 18.2s (LMS Tech)

| NO. | DATE | BY | REVISION |
|-----|----------|-----|----------------|
| 1 | 07/12/13 | AHG | RECORD DRAWING |

NOTICE

IF THIS BAR DOES NOT MEASURE 1" THEN DRAWING IS NOT TO SCALE

AHG DESIGNED
RLF DRAWN
GEC CHECKED

RECORD DRAWING
SEE DISCLAIMER, SHEET 1.
VERSION 4.1
12-9-97

MSA Murray, Smith & Associates, Inc.
Engineers/Planners
121 S.W. Salmon, Suite 900 PHONE 503-225-9010
Portland, Oregon 97204 FAX 503-225-9022

City of Sherwood Oregon

DOWNTOWN STREETSCAPE PHASE 2 IMPROVEMENTS

WATER QUALITY FACILITY SWALE MAINTENANCE DETAILS - 3

PROJECT NO.: 12-1319.1201 SCALE: AS SHOWN DATE: NOVEMBER 2012

SHEET **WQ-4**
45 of 78

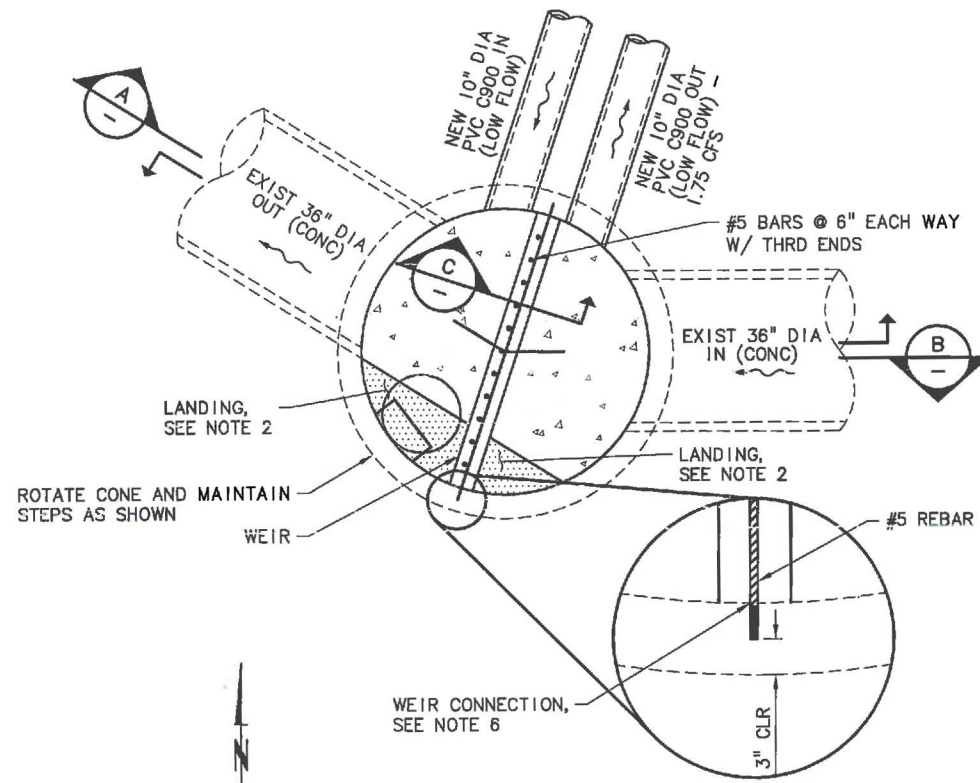

PLAN
SCALE: NTS

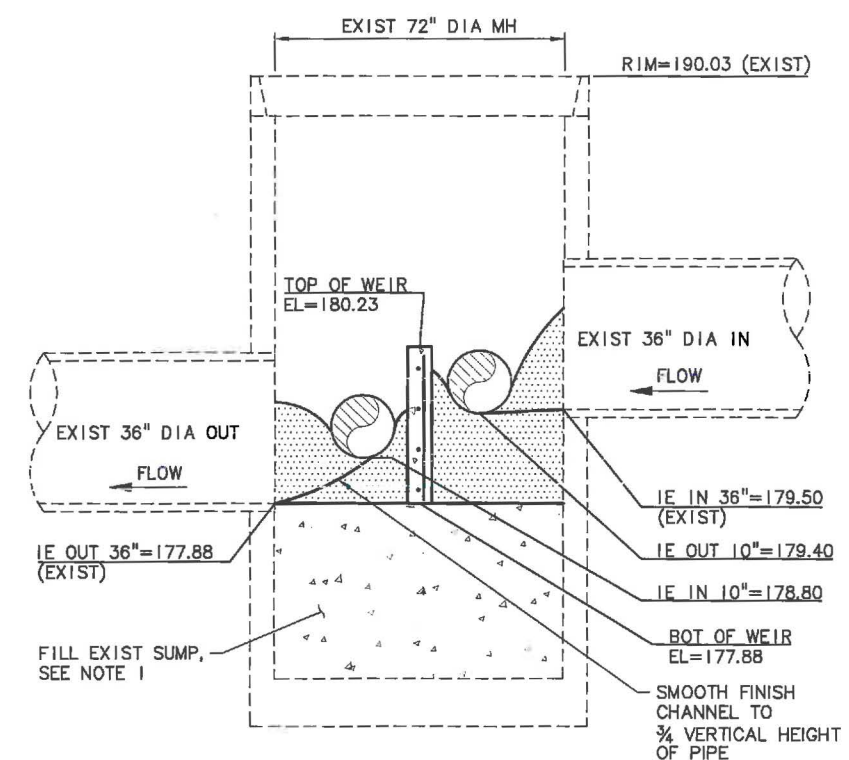

SECTION A
SCALE: NTS

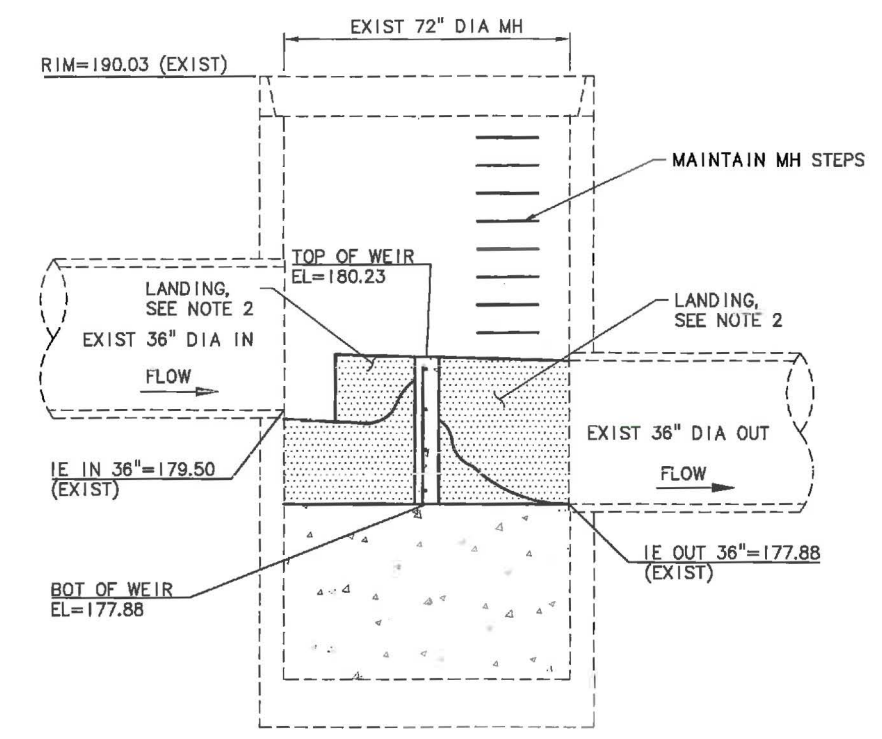

SECTION B
SCALE: NTS

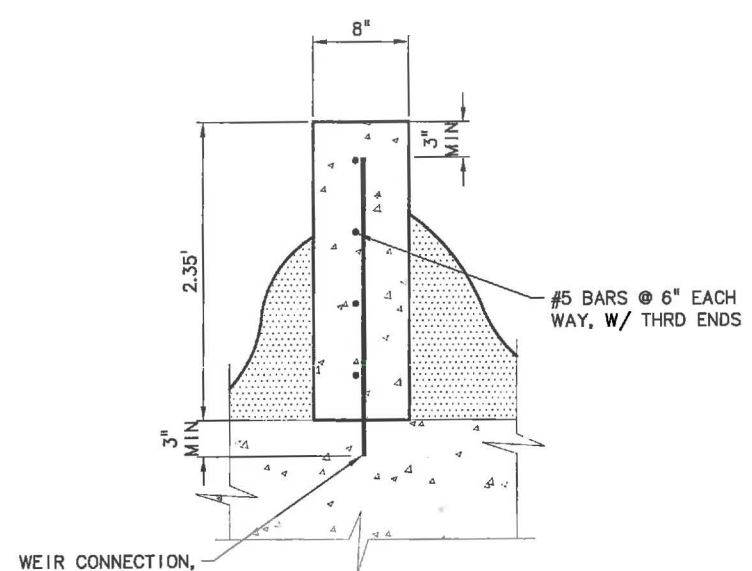

SECTION C
SCALE: NTS

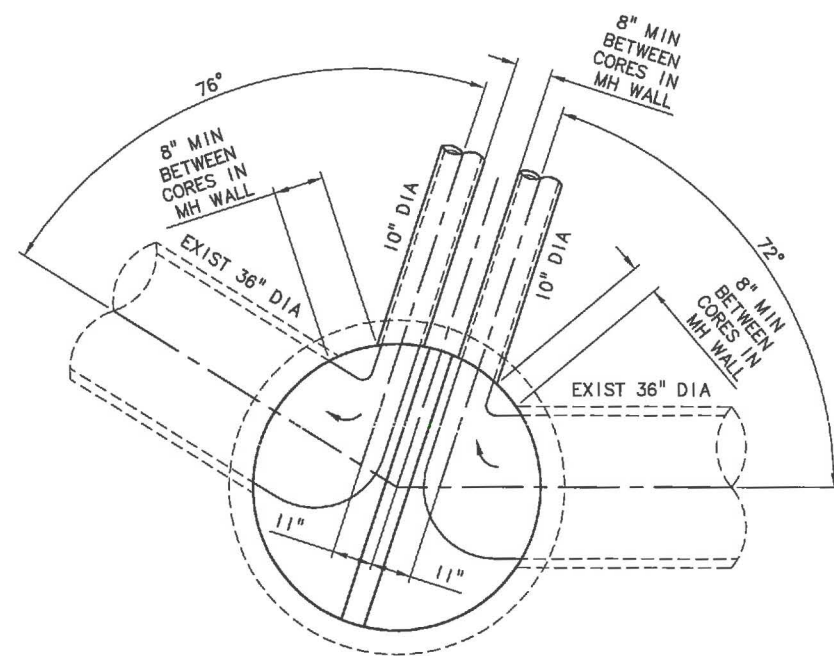

CHANNEL DETAIL
SCALE: NTS

- NOTES:**
1. FILL EXISTING SUMP WITH COMMERCIAL GRADE CONCRETE TO ELEVATION 177.88 ALONG CENTERLINE OF WEIR.
 2. AFTER FILLING SUMP, CONSTRUCT CHANNELS AND LANDING. SLOPE TOP OF LANDING TO BE 1 INCH PER FOOT TOWARDS THE CENTER OF STRUCTURE.
 3. ALL BARS SHALL BE PLACED 2" CLEAR OF THE NEAREST FACE OF CONCRETE UNLESS SHOWN OTHERWISE.
 4. FOR DETAILS NOT SHOWN, SEE CITY OF SHERWOOD DRAWINGS IN CIVIL SHEETS.
 5. WEIR CONNECTION TO CONCRETE FILLED MANHOLE BASE TO INCLUDE EMBEDDING #5 BARS INTO BASE A MINIMUM OF 3". SEAL JOINT WITH EPOXY.
 6. WEIR CONNECTION TO EXISTING MANHOLE WALLS TO INCLUDE EMBEDDING #5 BARS INTO WALLS HALFWAY, SEAL JOINT WITH EPOXY.

G:\PDX\Projects\12\1319\CAD\DWG\SHEETS\WATER QUALITY\12-1319-OR-WQ-R.dwg WQ-5 6/28/2013 4:45 PM RLF 18.2s (LMS Tech)

CONSTRUCTION NOTES FOR REFERENCE ONLY

| NO. | DATE | BY | REVISION |
|-----|----------|-----|----------------|
| 1 | 07/12/13 | AHG | RECORD DRAWING |

NOTICE

0 1/2 1

IF THIS BAR DOES NOT MEASURE 1" THEN DRAWING IS NOT TO SCALE

AHG DESIGNED
RLF DRAWN
GEC CHECKED

RECORD DRAWING

SEE DISCLAIMER, SHEET 1.

VERSION 4.1
12-9-97

MSA Murray, Smith & Associates, Inc.
Engineers/Planners

121 S.W. Salmon, Suite 900 PHONE 503-225-9010
Portland, Oregon 97204 FAX 503-225-9022

City of Sherwood Oregon

DOWNTOWN STREETSCAPE PHASE 2 IMPROVEMENTS

WATER QUALITY FACILITY MANHOLE MODIFICATION DETAILS

PROJECT NO.: 12-1319.1201 SCALE: AS SHOWN DATE: NOVEMBER 2012

SHEET **WQ-5**

46 of 78

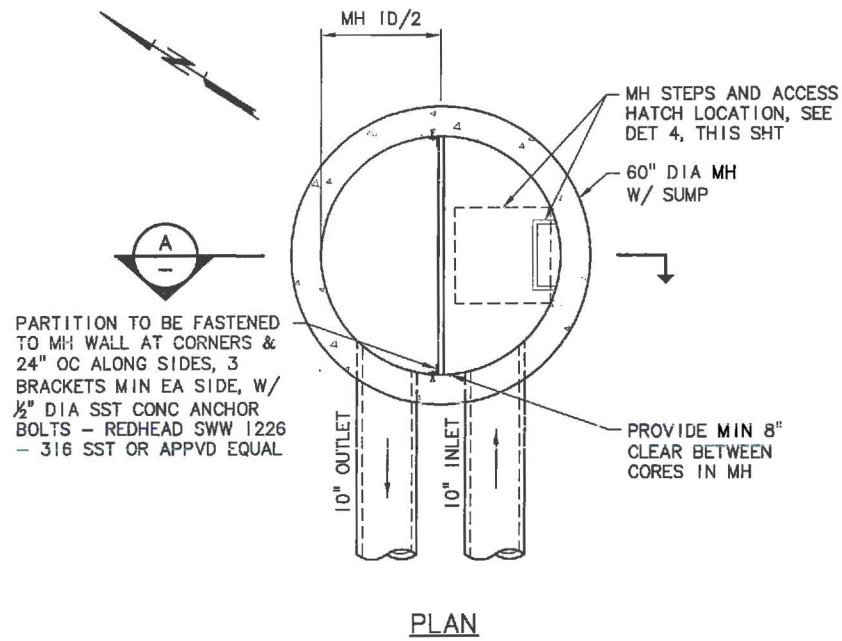

PLAN

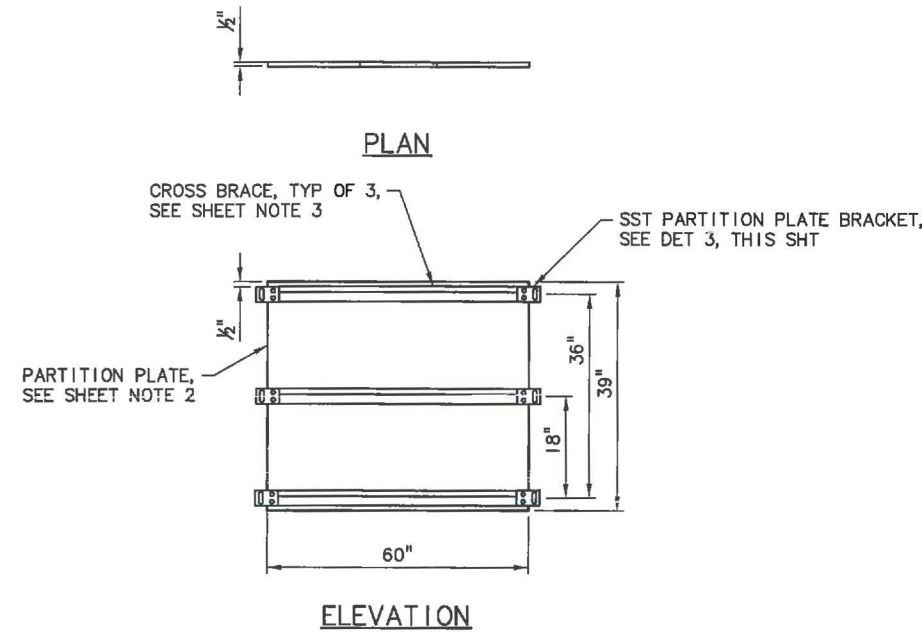

ELEVATION

PARTITION PLATE DETAIL 2

SCALE: NTS

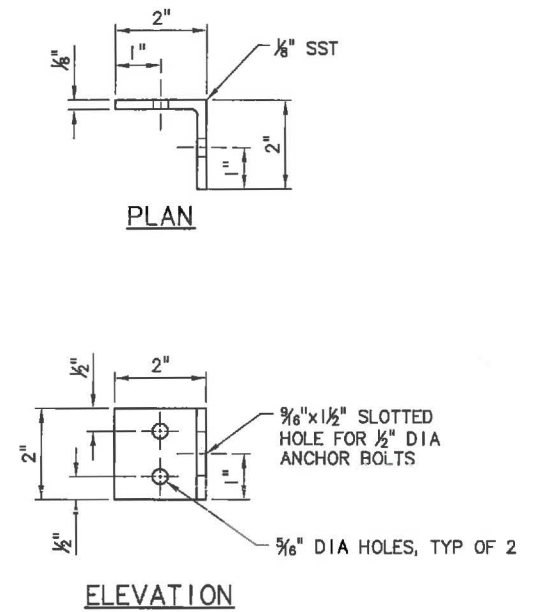

ELEVATION

STAINLESS STEEL PARTITION PLATE BRACKET 3

SCALE: NTS

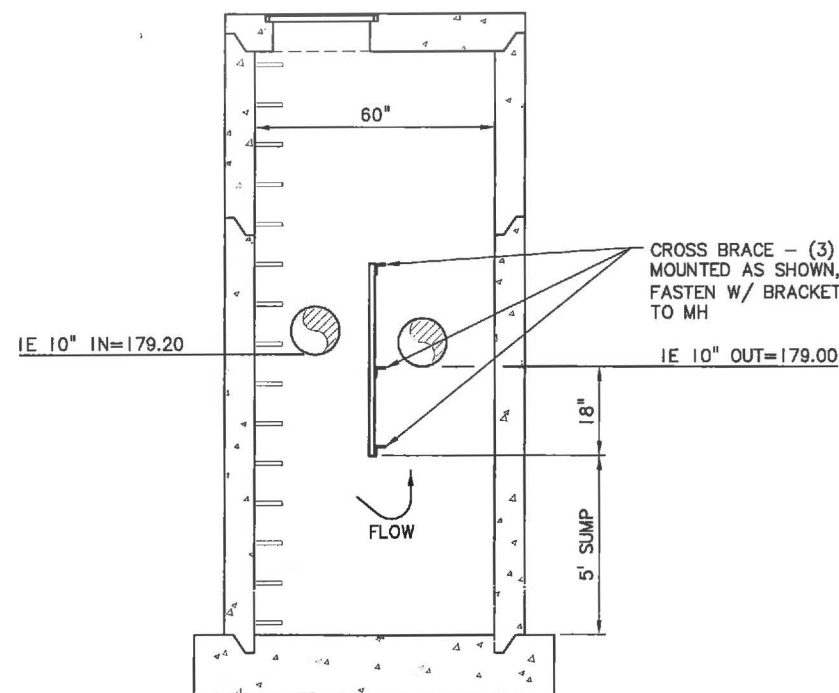

SECTION

SCALE: NTS

60" SEDIMENTATION MANHOLE DETAIL 1

SCALE: NTS

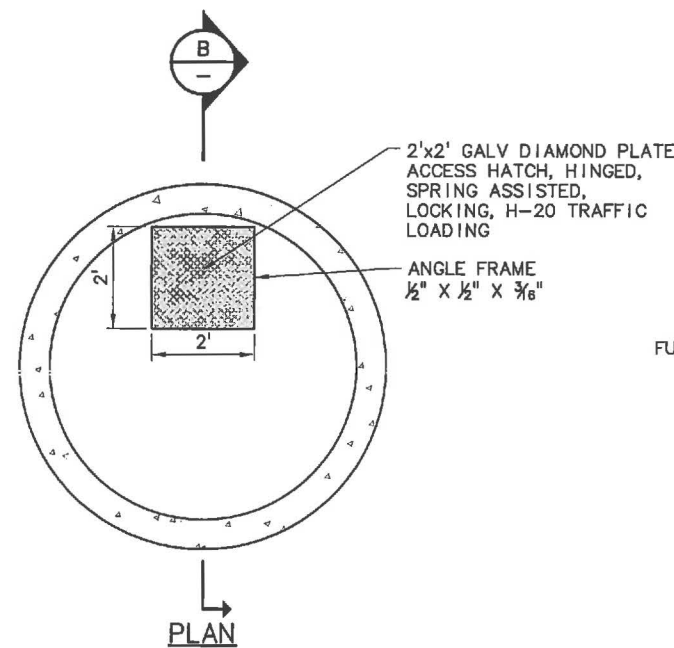

PLAN

MANHOLE TOP SLAB 4

SCALE: NTS

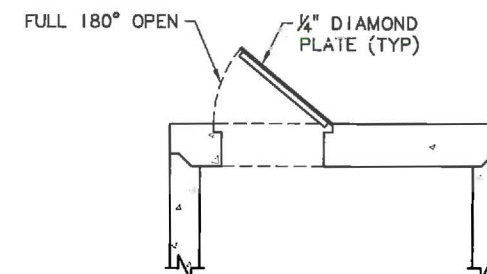

SECTION

SCALE: NTS

SHEET NOTES:

1. HARDWARE, FASTENERS AND ANCHORS TO BE STAINLESS STEEL.
2. PARTITION TO BE CONSTRUCTED OF HIGH DENSITY POLYETHYLENE (HDPE), 1/2" THICK ASTM D1248-78.
3. CROSS BRACE L 2 1/2"x1 1/2"x3/8" HOT DIP GALVANIZE, ASTM A-123. THREE PER PARTITION PLATE - FULL WIDTH. FASTEN TO PARTITION WITH STAINLESS BOLT, LOCKNUTS AND WASHER AT 12" CENTERS, FASTEN TO MANHOLE AT ENDS USING PARTITION PLATE BRACKETS.
4. FOR DETAILS NOT SHOWN, SEE CITY OF SHERWOOD STANDARD DRAWINGS ON SHEET WQ-7 AND STORM DETAILS ON CIVIL SHEETS.

C:\PDX_Projects\12\1319\CAD\DOT\SHEETS\WATER QUALITY\12-1319-OR-WQ-R.dwg WQ-6 6/28/2013 4:45 PM RLF 16.2s (LMS Tech)

| NOTICE | |
|--|--|
| 0 1/2 1 | |
| IF THIS BAR DOES NOT MEASURE 1" THEN DRAWING IS NOT TO SCALE | |

| | |
|-----------------|-----------------------------|
| AHG DESIGNED | RECORD DRAWING |
| RLF DRAWN | SEE DISCLAIMER, SHEET 1. |
| GEC CHECKED | VERSION 4.1 12-9-97 |

MSA Murray Smith & Associates, Inc.
Engineers/Planners
121 S.W. Salmon, Suite 900 PHONE 503-225-9010
Portland, Oregon 97204 FAX 503-225-9022

City of Sherwood Oregon
DOWNTOWN
STREETSCAPE
PHASE 2
IMPROVEMENTS

| | | | | | |
|---|--|-----------------|--|---------------------|--|
| PROJECT NO.: 12-1319.1201 | | SCALE: AS SHOWN | | DATE: NOVEMBER 2012 | |
| WATER QUALITY FACILITY SEDIMENTATION MANHOLE DETAILS - 1 | | | | SHEET WQ-6 | |
| | | | | 47 of 78 | |

CONSTRUCTION NOTES FOR REFERENCE ONLY

