

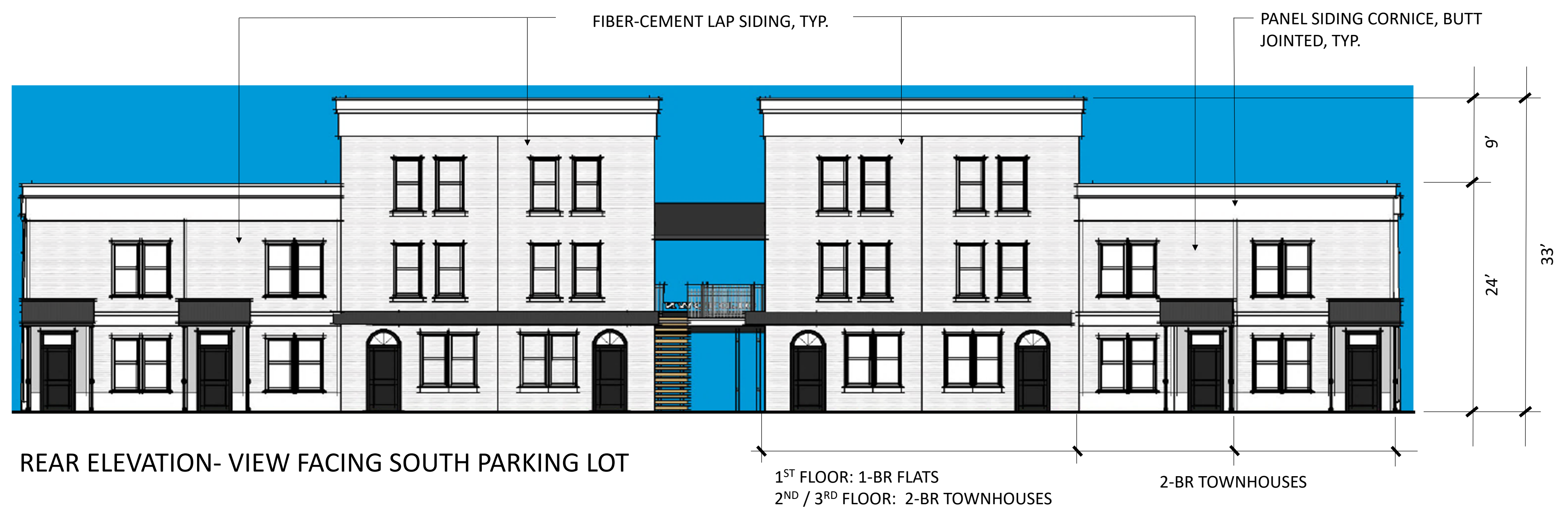

FRONT ELEVATION- VIEW FACING SW COLUMBIA STREET

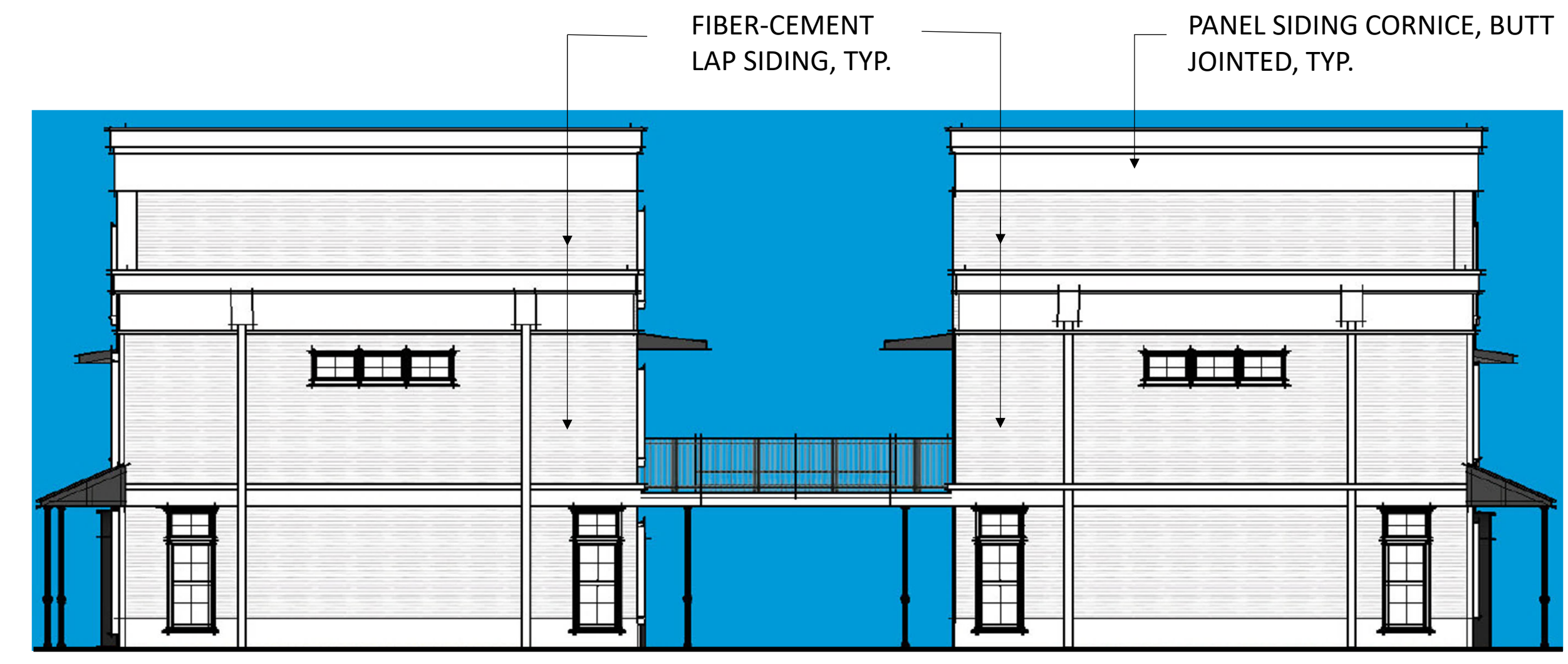

REAR ELEVATION- VIEW FACING SOUTH PARKING LOT



EAST ELEVATION

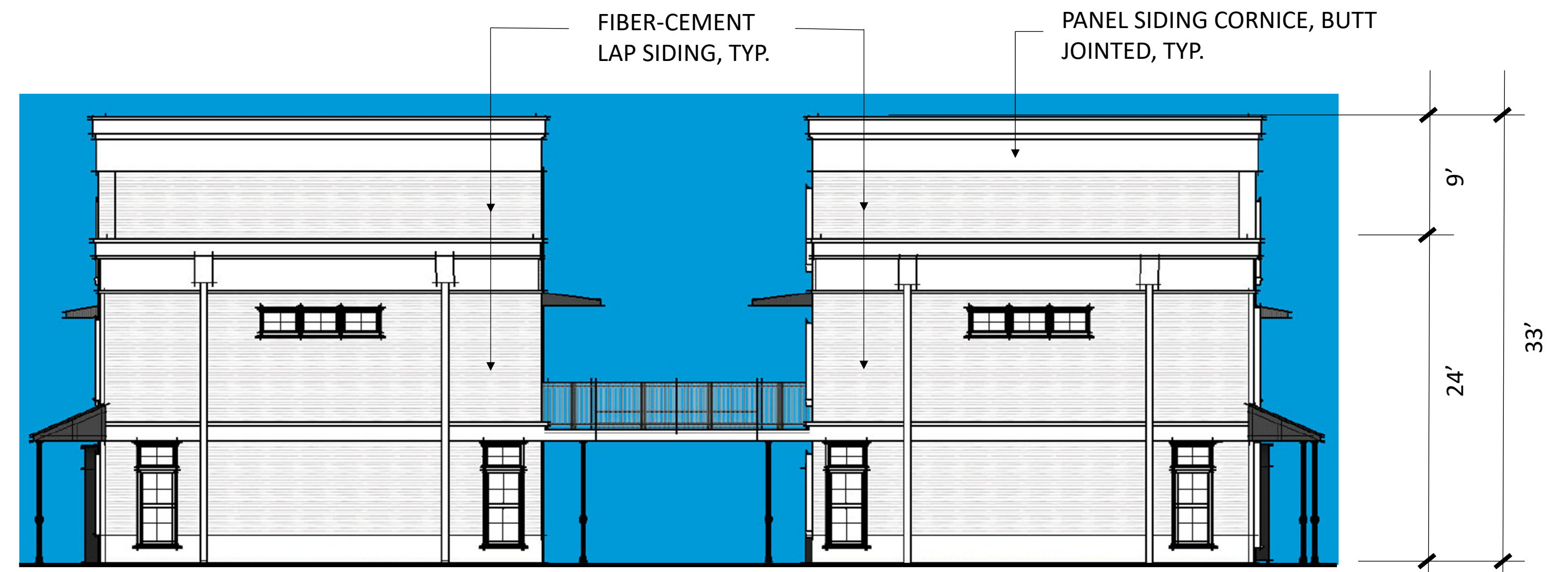

WEST ELEVATION

SCALE 1/8" = 1'-0"



PARAPET ROOFS. NO MECH EQUIPMENT PROPOSED.

CEMENT PLASTER OR BRICK SIDING

FIBER-CEMENT PANEL SIDING, BUTT JOINTED, TYP.

FIBER-CEMENT LAP SIDING, TYP.

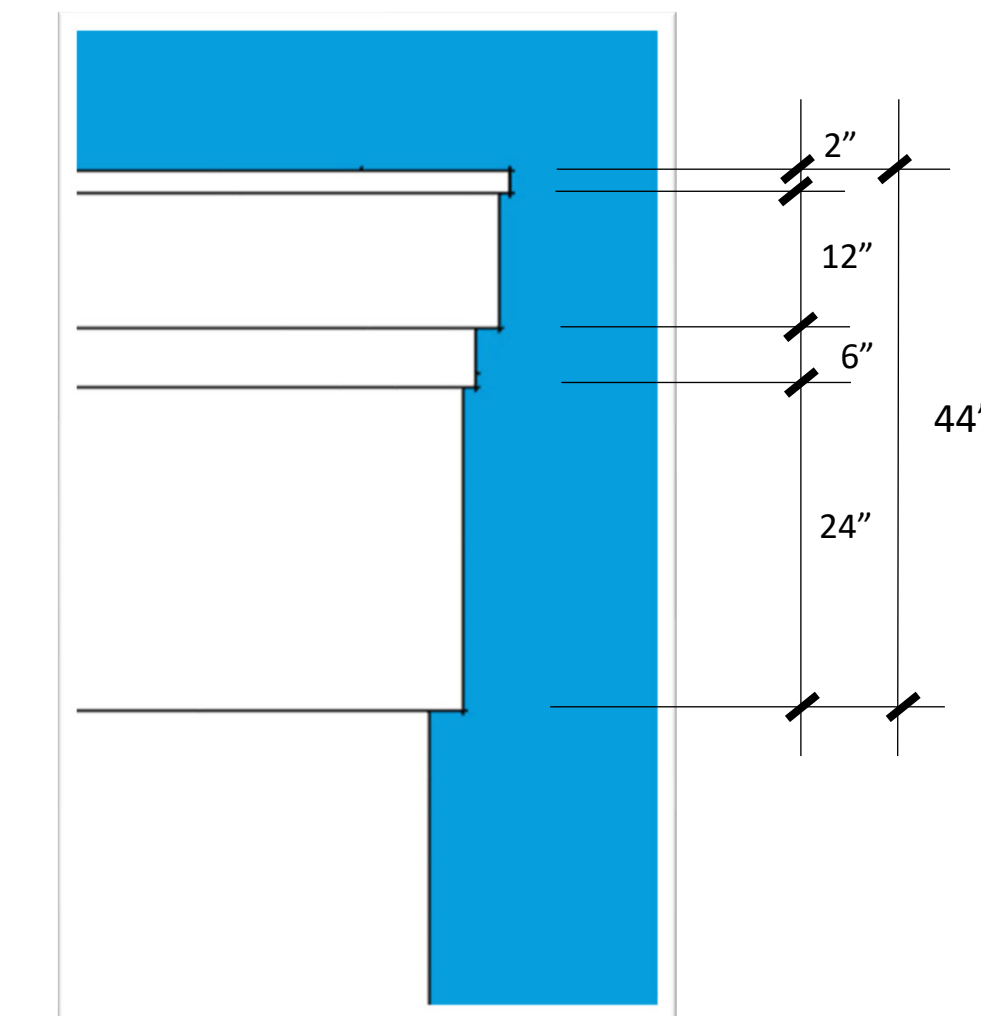

UPPER CORNICE

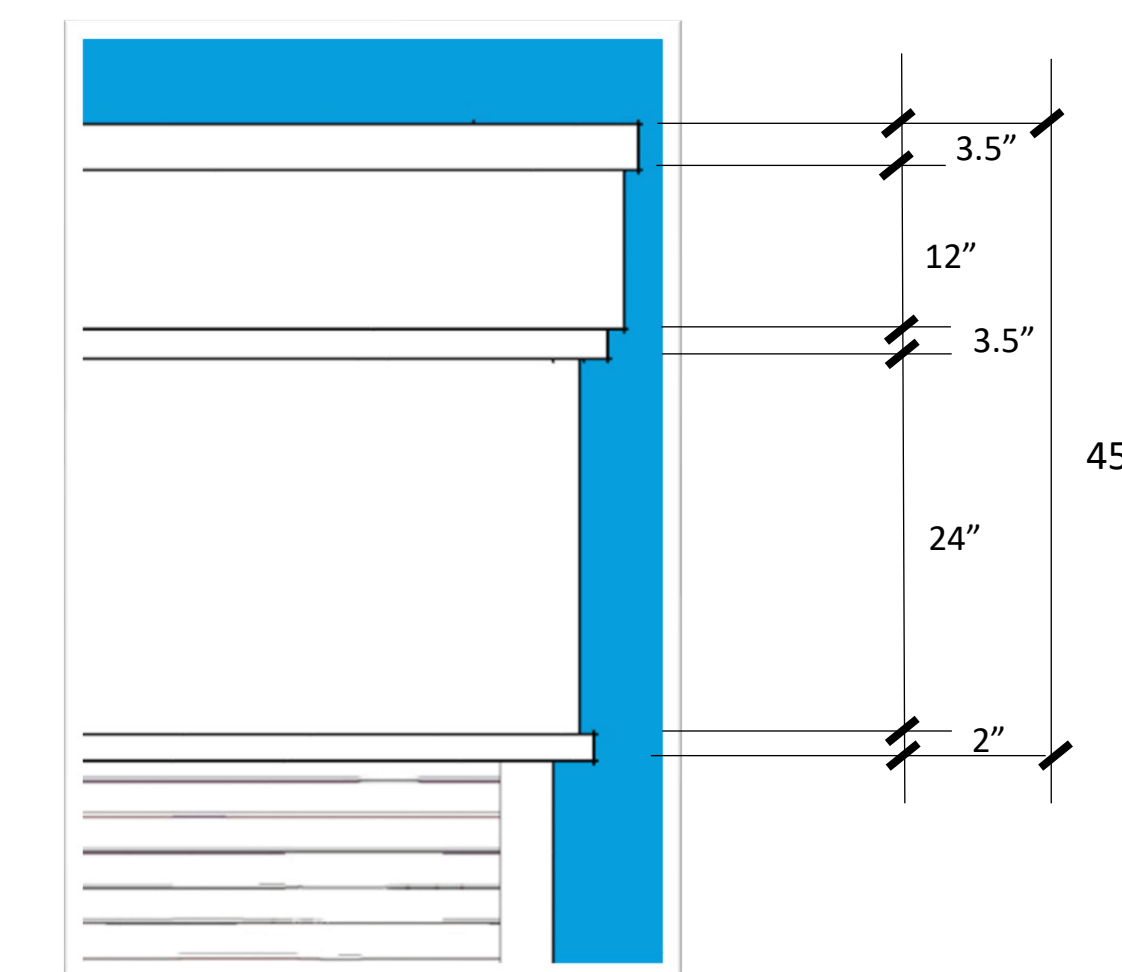

LOWER CORNICE

FRONT ELEVATION DETAIL

SINGLE-HUNG VINYL WINDOWS, WITH INTERNAL DIVIDERS FACING THE RIGHT OF WAY.

WINDOW TRIM TO BE PERPENDICULAR TO THE BUILDING PLAIN AT SILL, JAMB AND HEADER.



CORRUGATED METAL ROOFING. METAL PROFILE T.B.D. COVERED AREA = 6'X6' PER ENTRY

MAIN UNIT ENTRY DOORS FACING THE STREET

DECORATIVE METAL POSTS..

24" BUILDING BASE DISTINGUISHED BY COLOR OR MATERIAL.

ENLARGED ENTRY DETAIL

NOT TO SCALE

DATE: 10/15/21



**Edge**

Invest. Develop. Grow.

SHERWOOD OLDTOWN- RESIDENTIAL DEVELOPMENT  
15665 SW Willamette Street, Sherwood, OR 97140

CONCEPTUAL  
RENDERINGS

A-03

NOT TO SCALE

DATE: 10/15/21



FRONT PERSPECTIVE - FACING SW COLUMBIA STREET



VIEW OF REAR PARKING AREA.



FRONT ELEVATION PERSPECTIVE



**Edge**

Invest. Develop. Grow.

SHERWOOD OLDTOWN- RESIDENTIAL DEVELOPMENT  
15665 SW Willamette Street, Sherwood, OR 97140

CONCEPTUAL  
RENDERINGS

A-04

DATE: 10/15/21



ACCENT MATERIAL (TYPE AND LOCATION T.B.D.)

PROJECT SIGNAGE

ENTRY ACCESS GATES.  
ACCESS TO 2<sup>ND</sup> FLOOR  
LEVEL UNITS.

BREEZEWAY – PRIMARY RESIDENT ENTRY



ANTIQUE STREET LANTERN POST  
LIGHTS. ALONG STREET FRONTAGE  
AND DRIVE AILSE. (OPTIONAL)

ON-SITE LIGHTING



2<sup>ND</sup> FLOOR CIRCULATION / ELEVATED WALKWAY

SIGNAGE SHOWN AS A PLACEHOLDER. PROJECT  
BRANDING NOT DETERMINED AT THIS TIME.  
ILLUSTRATION 10' LONG BY 8" TALL.



CENTRAL STAIR – 2<sup>ND</sup> FLOOR ACCESS

NOT TO SCALE

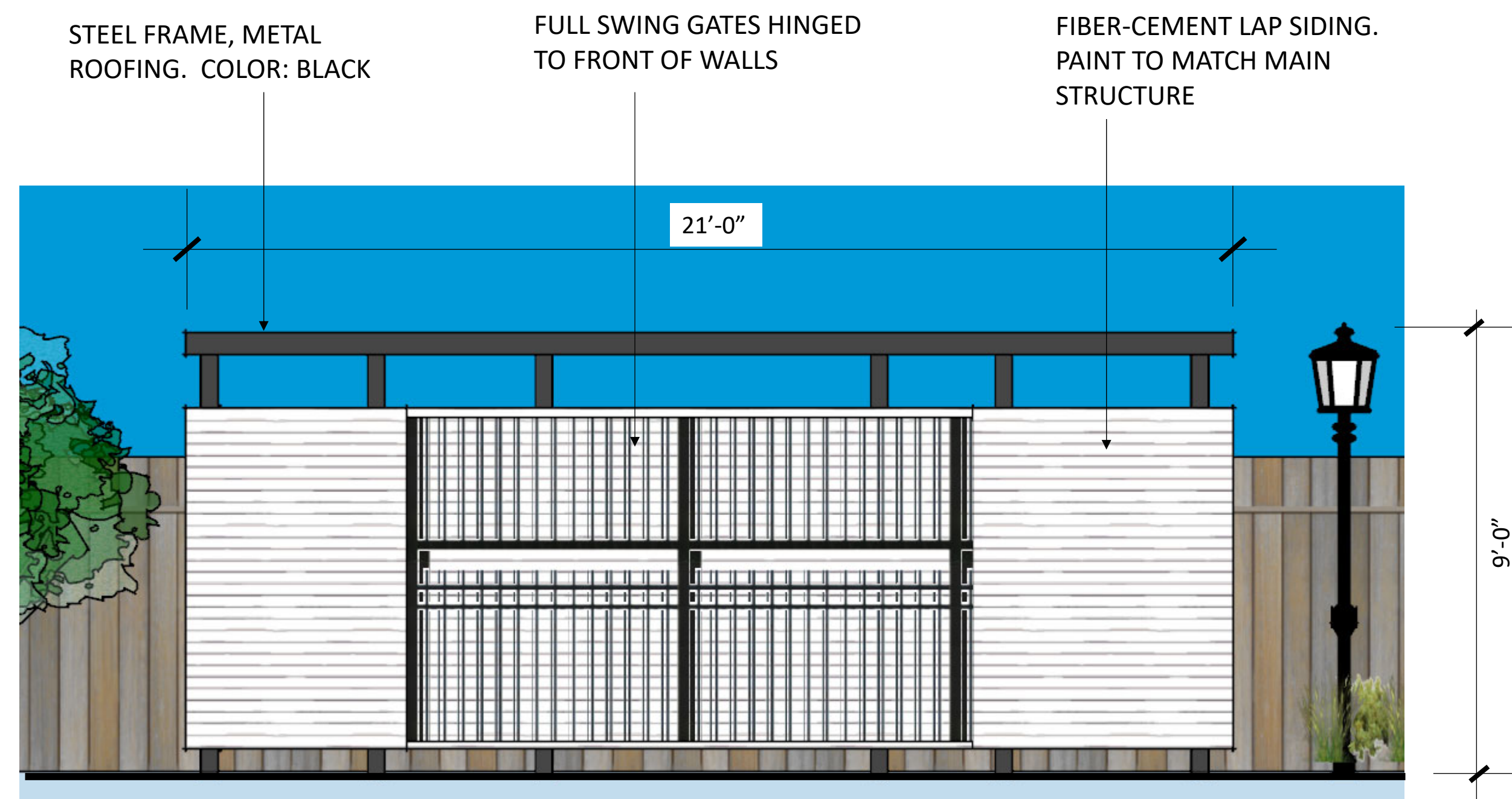

TRASH ENCLOSURE – FRONT (NORTH) ELEVATION

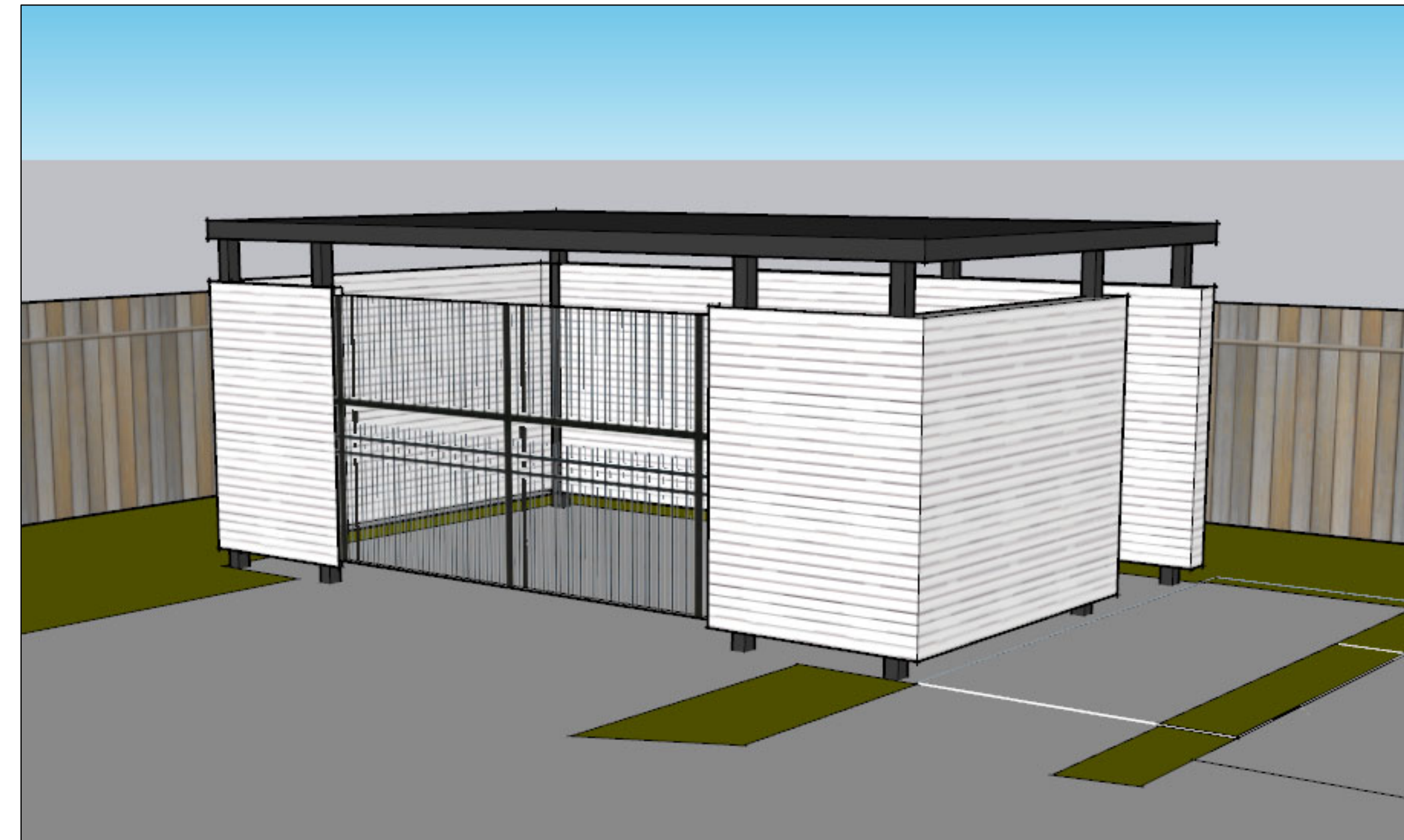

TRASH ENCLOSURE – PERSPECTIVE

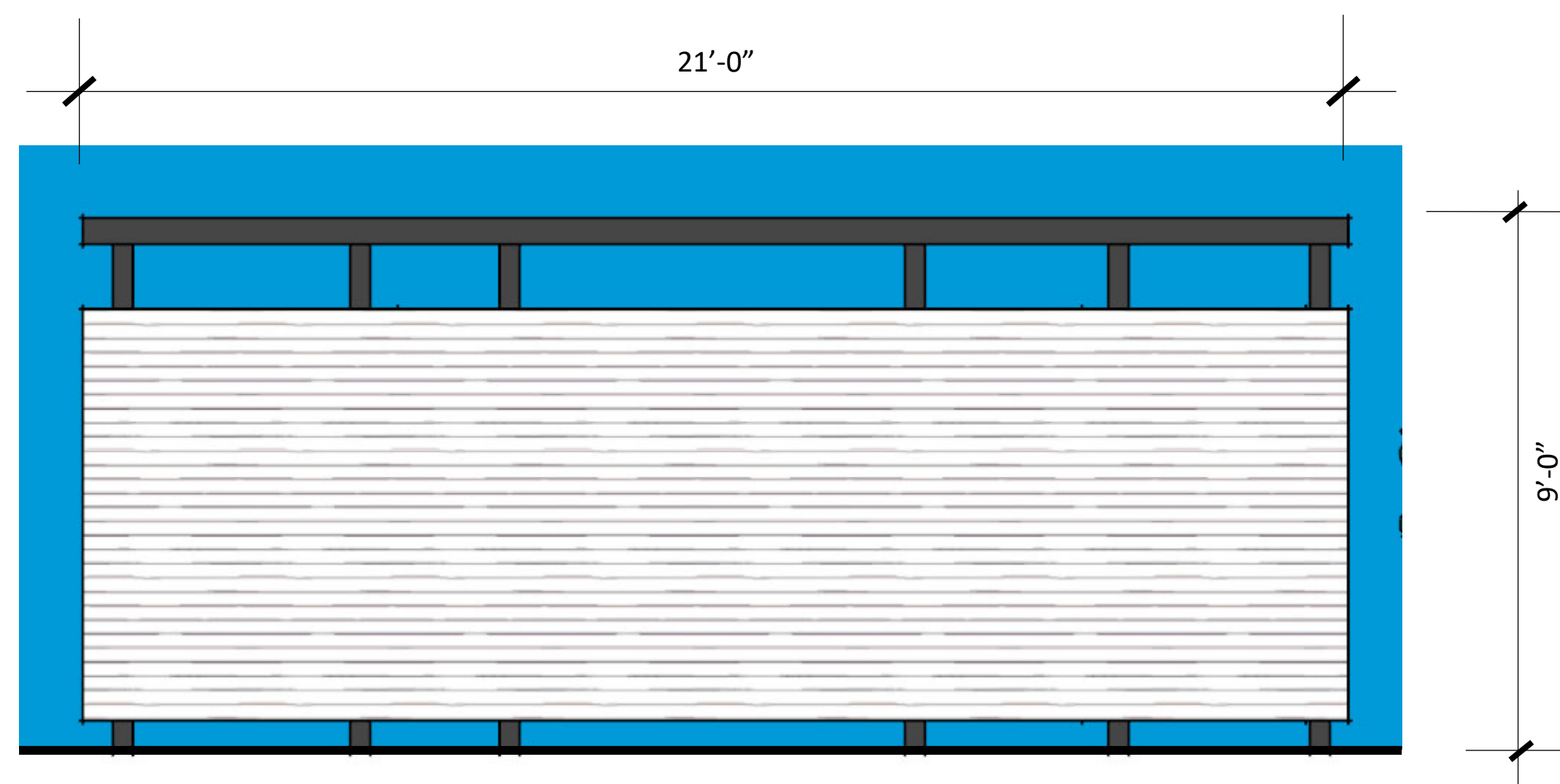

TRASH ENCLOSURE – SOUTH ELEVATION

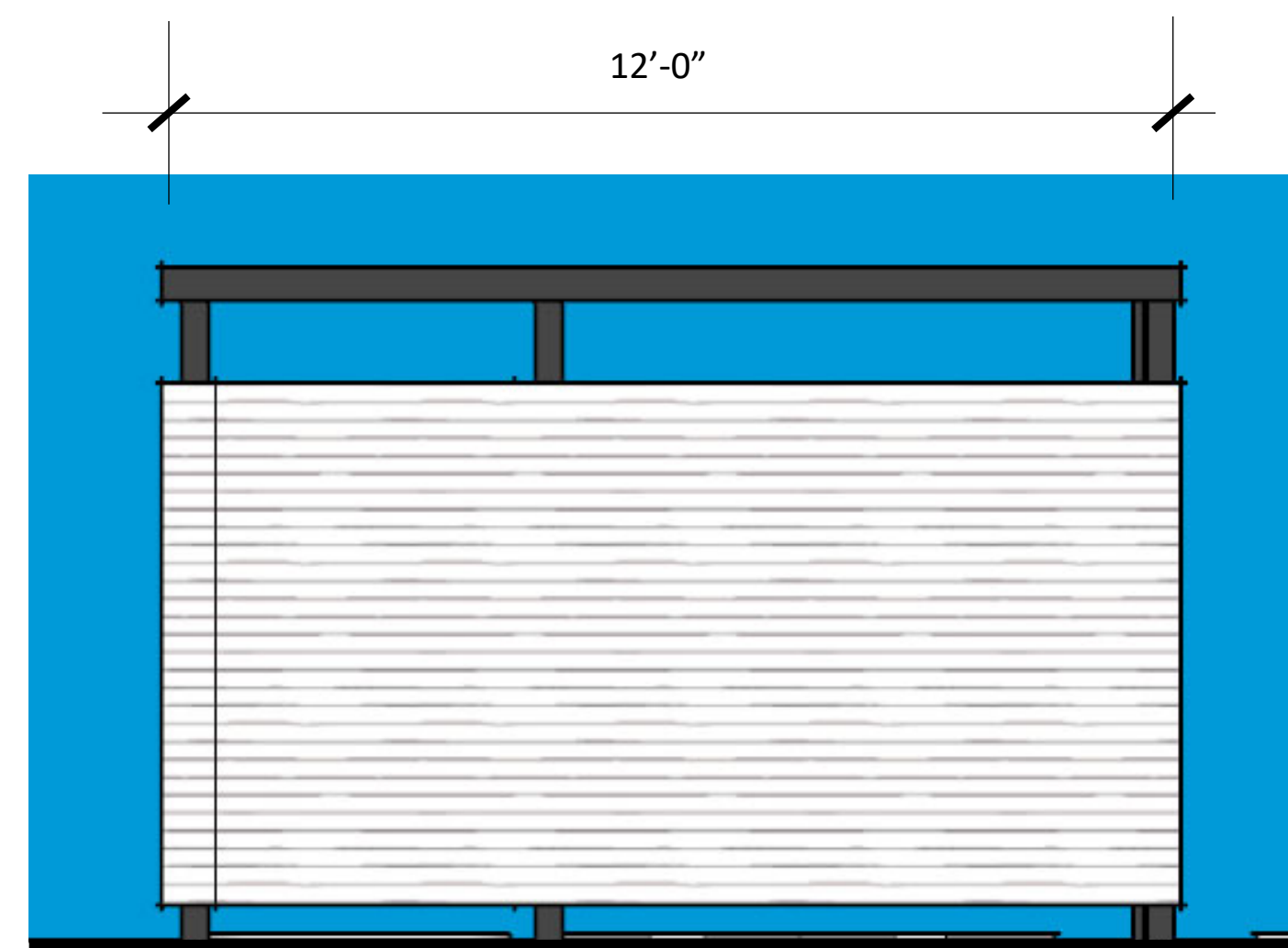

TRASH ENCLOSURE – EAST ELEVATION

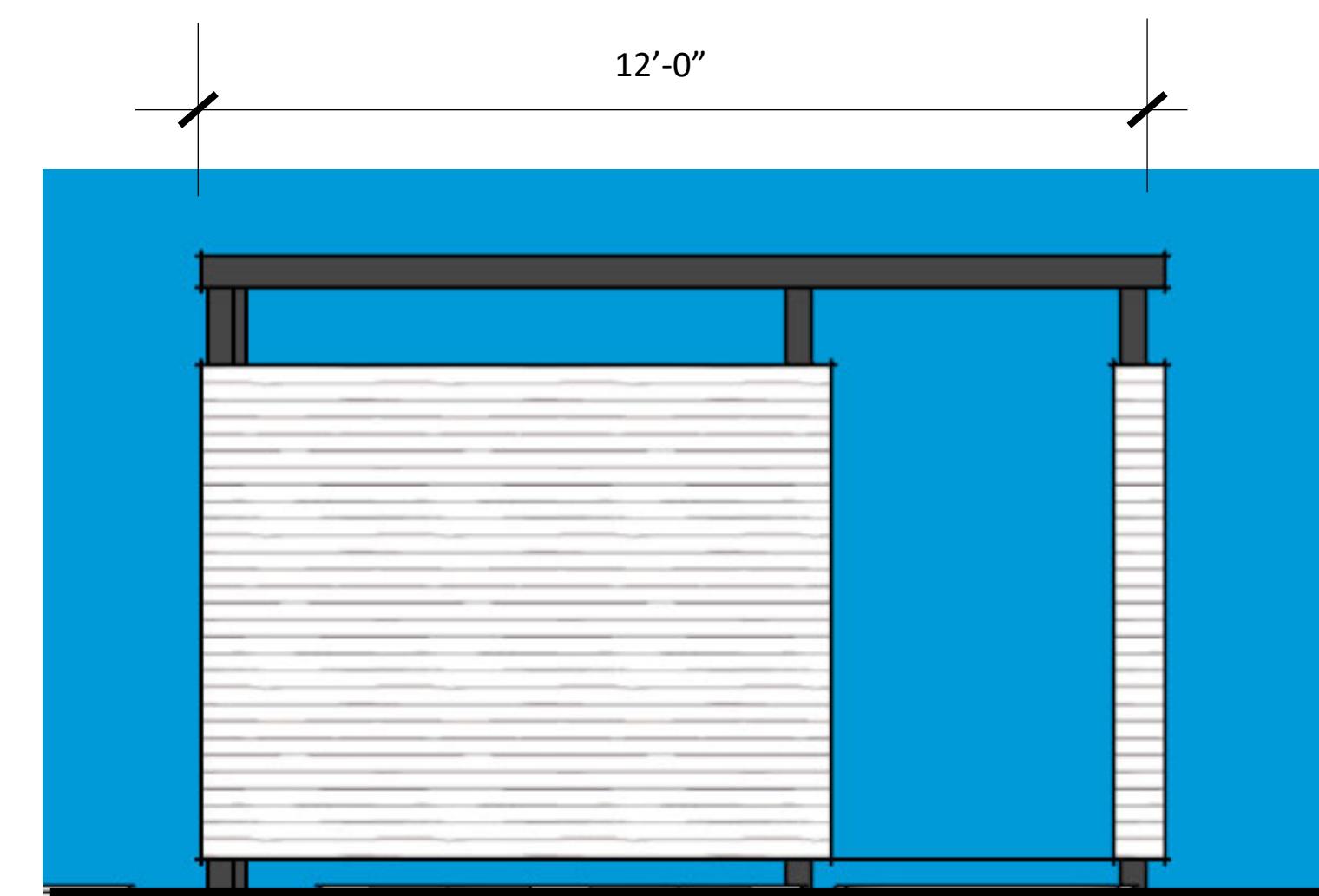

TRASH ENCLOSURE – WEST ELEVATION