

Appendix A  
Scoping Memo

## MEMORANDUM

---

Date: August 23, 2017

Project #: 21399

To: Bob Galati, PE, City of Sherwood  
Jinde Zhu, Washington County  
Avi Tayar, PE and Marah Danielson, ODOT Region 1

From: Kelly Laustsen, PE and Chris Brehmer, PE

Project: Brookman Area Residential Development

Subject: Transportation Study Scope of Work

---

The Holt Group is proposing to develop residentially zone land situated north of Brookman Road in Sherwood, Oregon as a multi-phase residential development. This memorandum identifies the anticipated trip generation associated with the development and outlines a proposed study scope for the transportation impact study. The Traffic Impact Analysis (TIA) will be prepared to address the requirements of City of Sherwood Development Code Section 16.106.080 as well as applicable Washington County and Oregon Department of Transportation (ODOT) review requirements.

### Project Background

The site is located north of Brookman Road with access proposed at multiple locations along Brookman Road. The site vicinity is shown in Figure 1 and a conceptual site plan is provided in Figure 2.

As shown in Figure 2, seven phases of development are proposed, with internal connections between phases 1 through 5. The full site is anticipated to be built out by 2023, with development starting in 2018 with buildout of Phase 1.

### Analysis Periods

The TIS will evaluate traffic operations for the following periods:

- 2017 Existing conditions
- Year 2018 background conditions (without the proposed development)
- Year 2018 total traffic conditions (with phase 1 of the proposed development)
- Year 2019 background conditions (with phase 1 of the proposed development)
- Year 2019 total traffic conditions (with phases 1-2 of the proposed development)

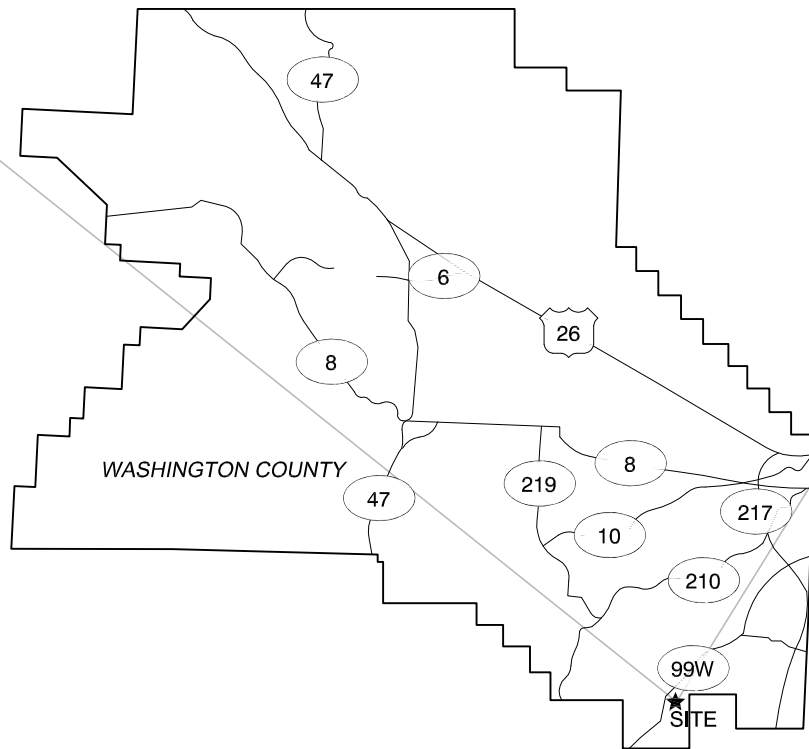
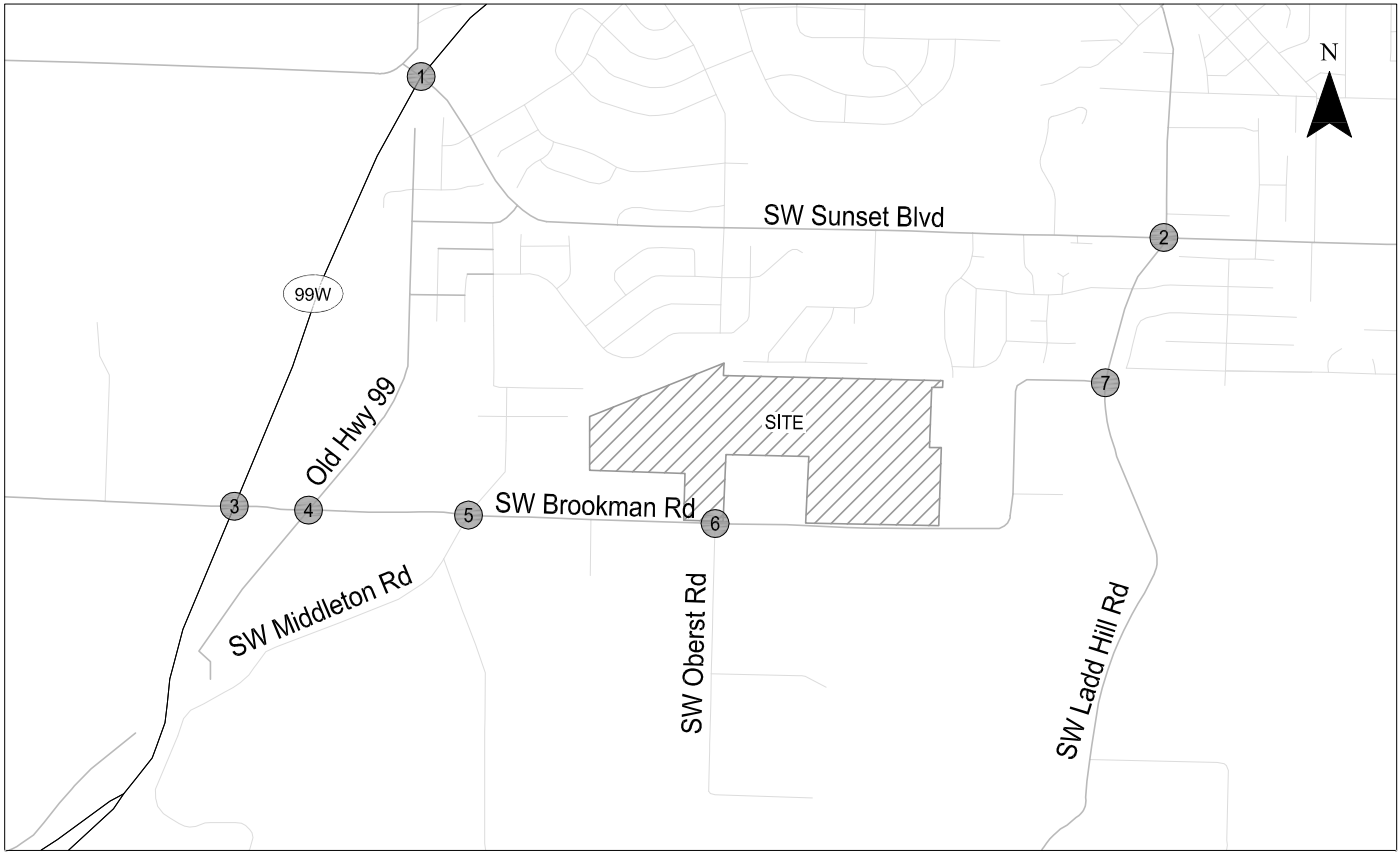

# - Study Intersections

Site Vicinity Map  
Sherwood, Oregon

Figure  
1

I:\kittelsohn.com\file\Projects\2121399 - Brookman Residential Development\dwg\figs\21399 figs.dwg Aug 11, 2017 - 2:36pm - kaustsen Layout Tab: 1\_vicinity

\\kittelson.com\fs1\HL\Projects\212121399 - Brookman Residential Development\dwg\figs\21399 figs.dwg Aug 10, 2017 - 11:47am - klausisen Layout Tab. 2\_SP Landscape

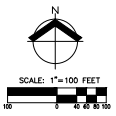
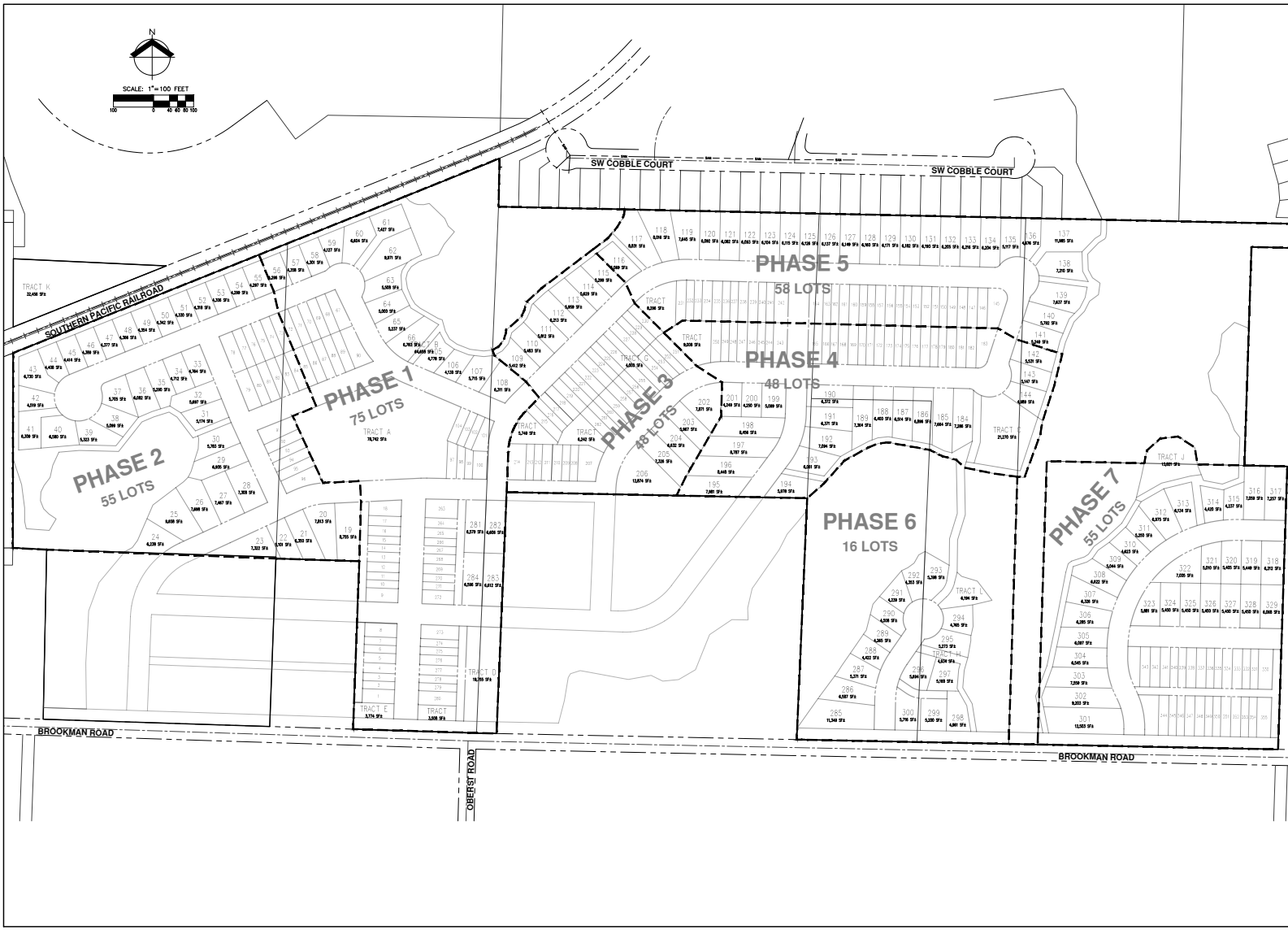

**AKS**  
 AKS ENGINEERING & FORESTRY, LLC  
 4200 N. W. 20th Ave.  
 Ft. Lauderdale, FL 33309-3022  
 954-583-9300  
 akseng.com

ENGINEERING • SURVEYING • NATURAL RESOURCES  
 FORESTRY • PLANNING • LANDSCAPE ARCHITECTURE

BROOKMAN AREA	OREGON
SHERWOOD	
CONCEPTUAL PUD LAYOUT	
DESIGNED BY: <b>SBT</b>	
DRAWN BY:	
CHECKED BY:	
DATE: 08-01-2017	
<b>PLANNING</b>	
DESIGN:	
JOB NUMBER:	
SHEET:	
<b>EX-1</b>	

Site plan received from AKS Engineering on August 7, 2017

Conceptual Site Plan  
Sherwood, Oregon

Figure  
2

- Year 2020 background conditions (with phases 1-2 of the proposed development)
- Year 2020 total traffic conditions (with phases 1-3 of the proposed development)
- Year 2021 background conditions (with phases 1-3 of the proposed development)
- Year 2021 total traffic conditions (with phases 1-4 of the proposed development)
- Year 2022 background conditions (with phases 1-4 of the proposed development)
- Year 2022 total traffic conditions (with phases 1-5 of the proposed development)
- Year 2023 background conditions (with phases 1-5 of the proposed development)
- Year 2023 total traffic conditions (with phases 1-7 of the proposed development)

The traffic analysis will evaluate intersection operations during the weekday AM and PM peak hours.

### Trip Generation

Preliminary trip generation estimates for the proposed development were prepared based on information presented in the *Trip Generation Manual* (Reference 1). The estimated trip generation is shown in Table 1.

Table 1. Trip Generation Estimate

Phase	Land Use	ITE Code	Size	Daily Trips	Weekday AM Peak Hour			Weekday PM Peak Hour		
					Total	In	Out	Total	In	Out
1	Single-Family Detached	210	19 units	181	14	4	11	19	12	7
	Res. Condo/Townhouse	230	56 units	325	25	4	20	29	19	10
	<b>Net New Phase 1 Trips</b>			<b>506</b>	<b>39</b>	<b>8</b>	<b>31</b>	<b>48</b>	<b>31</b>	<b>17</b>
2	Single-Family Detached	210	37 units	352	28	7	21	37	23	14
	Res. Condo/Townhouse	230	18 units	105	8	1	7	9	6	3
	<b>Net New Phase 2 Trips</b>			<b>457</b>	<b>36</b>	<b>8</b>	<b>28</b>	<b>46</b>	<b>29</b>	<b>17</b>
3	Single-Family Detached	210	12 units	114	9	2	7	12	8	4
	Res. Condo/Townhouse	230	36 units	209	16	3	13	19	13	6
	<b>Net New Phase 3 Trips</b>			<b>323</b>	<b>25</b>	<b>5</b>	<b>20</b>	<b>31</b>	<b>21</b>	<b>10</b>
4	Single-Family Detached	210	21 units	200	16	4	12	21	13	8
	Res. Condo/Townhouse	230	27 units	157	12	2	10	14	9	5
	<b>Net New Phase 4 Trips</b>			<b>357</b>	<b>28</b>	<b>6</b>	<b>22</b>	<b>35</b>	<b>22</b>	<b>13</b>
5	Single-Family Detached	210	26 units	248	20	5	15	26	16	10
	Res. Condo/Townhouse	230	32 units	186	14	2	12	17	11	6
	<b>Net New Phase 5 Trips</b>			<b>434</b>	<b>34</b>	<b>7</b>	<b>27</b>	<b>43</b>	<b>27</b>	<b>16</b>
6	Single-Family Detached	210	16 units	152	12	3	9	16	10	6
	<b>Net New Phase 6 Trips</b>			<b>152</b>	<b>12</b>	<b>3</b>	<b>9</b>	<b>16</b>	<b>10</b>	<b>6</b>
7	Single-Family Detached	210	29 units	276	22	6	16	29	18	11
	Res. Condo/Townhouse	230	26 units	151	11	2	9	14	9	5
	<b>Net New Phase 7 Trips</b>			<b>427</b>	<b>33</b>	<b>8</b>	<b>25</b>	<b>43</b>	<b>27</b>	<b>16</b>
<b>Net New Phases 1-7 Trips</b>				<b>2,656</b>	<b>207</b>	<b>45</b>	<b>162</b>	<b>262</b>	<b>167</b>	<b>95</b>

As shown in Table 1, the proposed development is estimated to generate 2,656 daily trips, including 207 trips during the weekday AM peak hour and 262 trips during the weekday PM peak.

## Study Intersections

City of Sherwood Development Code Section 16.106.080 requires analysis of all intersections of where the analysis shows that fifty (50) or more peak hour vehicle trips can be expected to result from the development. Based on these requirements, anticipated trip generation, and initial discussions with City, County, and ODOT staff, we propose to study the following intersections:

1. Highway 99W/SW Sunset Boulevard
  2. SW Ladd Hill Road/SW Sunset Boulevard
  3. Highway 99W/SW Brookman Road
  4. Old Highway 99 W/SW Brookman Road
  5. SW Middleton Road/SW Brookman Road
  6. SW Oberst Road/SW Brookman Road
  7. SW Ladd Hill Road/SW Brookman Road
- All proposed site accesses on SW Brookman Road

These intersections are also shown on Figure 1. We will analyze operations and request the most recent five years of crash data from ODOT at the study area intersections.

## Trip Distribution

Existing traffic count data, surrounding land uses, and the *Brookman Addition Concept Plan* (Reference 2) were used to generate a trip distribution pattern, shown in Figure 3. This distribution pattern will be used for the assignment of weekday AM and PM peak hour site trips.

## Existing and Forecast Traffic Volumes

Existing traffic volumes will be determined from manual turn movement counts at the study intersections on a typical weekday during the morning peak period (7:00 – 9:00 AM) and evening peak period (4:00 – 6:00 PM).

Forecast traffic volumes will be developed based on regional traffic growth within the study area as well as growth related to City-identified approved in-process developments. ***Would you please provide the preferred annual growth rate, any approved developments that should be assumed as “in-process,” as well as any planned improvements in the study area that should be accounted for?***

## Analysis Methodology

All intersections will be analyzed using Synchro 9 and the 2000 *Highway Capacity Manual (HCM)*.

\\kittelson.com\fs1\HL\_Projects\2121399 - Brookman Residential Development\kigs\figs\21399 figs.dwg Aug 18, 2017 - 4:38pm - kausteen Layout Tab: 3\_trip dist

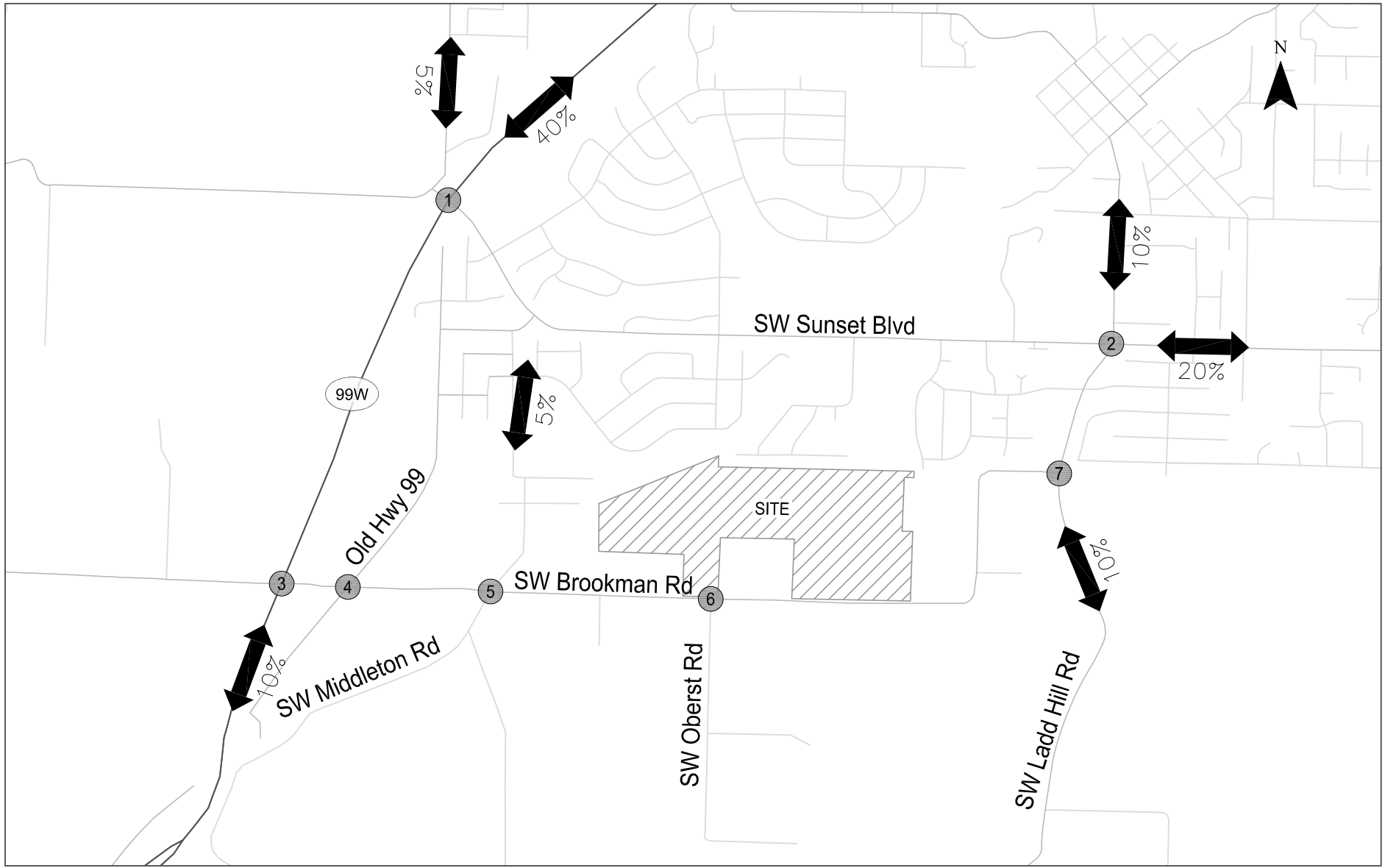

Trip Distribution  
Sherwood, Oregon

Figure  
3

## Performance Measures & Operating Standards

Intersection performance measures used will include level of service (LOS), volume-to-capacity ratio (V/C), and delay. Intersection operating standards adopted by Washington County, ODOT and the City are summarized below.

### *Washington County Operating Standards*

Washington County has jurisdiction over Brookman Road. The County has defined operating standards for signalized and stop controlled intersections assuming a peak hour (60-minute analysis) period as follows:

- **Signalized intersections:** the maximum peak hour intersection volume-to-capacity ratio shall be no greater than 0.99.
- **Unsignalized intersections:** no movement shall experience a volume-to-capacity ratio greater than 0.99.

### *ODOT Operating Standards*

ODOT operates and maintains OR 99W (Pacific Highway West). ODOT's operating standard for signalized intersections along Highway OR 99W in the study area is an intersection V/C ratio no greater than 0.99 during the peak 15-minutes as identified in Table 7 of the *Oregon Highway Plan* (Reference 3).

### *Sherwood Operating Standards*

The City defers to ODOT and Washington County standards for facilities under the jurisdiction of ODOT or Washington County. For other intersections, the following local city targets apply:

- **Signalized intersections:** level of service D or a volume to capacity ratio equal to or less than 0.85.
- **Unsignalized two-way stop-control (TWSC) intersections:** level of service E or a volume to capacity ratio equal to or less than 0.90.

For all intersections, level of service performance should first be assessed and if it is not met the v/c target is considered.

## Next Steps

We look forward to working with you on this project. Please let us know if you have any questions, comments, or additional direction related to the scoping information presented in this memorandum.

Thank you in advance for your assistance.



## References

1. Institute of Transportation Engineers. *Trip Generation, 9<sup>th</sup> Edition*. 2012.
2. DKS Associates. *Brookman Addition Concept Plan: Committee Recommended Plan – Transportation Analysis*. April 22, 2008.
3. Oregon Department of Transportation. *1999 Oregon Highway Plan*. Amended May 2015.

## Kelly Laustsen

---

**From:** Garth Appanaitis <gaa@dksassociates.com>  
**Sent:** Wednesday, October 18, 2017 4:31 PM  
**To:** Kelly Laustsen  
**Cc:** Chris Brehmer; GalatiB@SherwoodOregon.gov  
**Subject:** Re: Brookman Scope

Hi Kelly,

Here are the comments on the scoping memo:

- Trip Generation - Using the average trip rate rather than the equation for those residential uses is sufficient. For this size of overall use, the difference is nominal and would add unnecessary complexity and confusion with the TDT.
- Study intersections - In addition to the intersections shown, the following intersections should be included:
  - Intersections requested by ODOT on OR99W. Based on the initial trip generation and distribution, I would anticipate that they may ask for other intersections to the north. However, this is ODOT discretion.
  - Sunset/Timbrel
  - Sunset/Woodhaven
  - Sunset/Baker/Murdock
- In Process Development - The hotel site on Meinecke should be included and the traffic study can be found here: <https://www.sherwoodoregon.gov/planning/project/sherwood-hotel> If ODOT requests additional study intersections on OR 99W to the north, you should also include trips from the Cedar Creek Plaza. Links to other traffic studies are included here: [https://www.sherwoodoregon.gov/projects?tid=All&field\\_project\\_status\\_value=All&field\\_project\\_type\\_tid=93&keys=&=Apply](https://www.sherwoodoregon.gov/projects?tid=All&field_project_status_value=All&field_project_type_tid=93&keys=&=Apply)
- Future background traffic growth - Based on Sherwood's TSP and travel model, use 1% per year growth on ODOT highway approaches and 2% for all other approaches.
- Trip Distribution - The 5% internal distribution should be clarified and may not be appropriate given the existing mix of uses in the area (residential) and the proposed uses (residential). In order to assume 5% internal distribution, please clarify the intended origin/destination from these proposed households, or shift the 5% to other external gateways.
- Scope of traffic study - The Aug 23 memo describes some of the methods and assumptions for the TIA, but does not comprehensively indicate what other items will be included in the study - such as safety analysis, description of ped/bike/transit network, assessment of pedestrian crossing safety, etc. Providing a full list of these items that are planned to include in the TIA will facilitate the completeness review.

Bob - Do you have anything else to add?

Thanks,  
Garth

On Tue, Oct 17, 2017 at 3:38 PM, Kelly Laustsen <[klaustsen@kittelsohn.com](mailto:klaustsen@kittelsohn.com)> wrote:

Hi Garth,

I wanted to follow-up on our call from the week before last. I believe you were going to send a summary of comments on the scope, preferred growth rate, and list of in-process developments to include. Can you please send this information at your earliest convenience?

## Kelly Laustsen

---

**From:** TAYAR Abraham \* Avi <Abraham.TAYAR@odot.state.or.us>  
**Sent:** Thursday, September 14, 2017 4:15 PM  
**To:** 'Joe Schiewe'; GalatiB@SherwoodOregon.gov; Jinde\_Zhu@co.washington.or.us  
**Cc:** Alex Hurley; Chris Goodell; Chris Brehmer; Robinson, Michael C. (Perkins Coie); Brandt Thissell; Rian Tuttle; DANIELSON Marah B; Kelly Laustsen  
**Subject:** RE: Scoping Memo: Brookman Area Residential Development

I have responded to KIA directly as indicated below; ODOT accept the proposed methodology as listed below:

- We could assess the AM and PM peak hour trip generation for the single family homes and townhomes using the equation for buildout of the site. Using the peak hour equations results in a net increase of 4 AM peak hour trips and 3 PM peak hour trips, as shown in the table below.

Thanks,

**Avi Tayar. P.E.** | Oregon Department of Transportation | Region 1 | Planning & Research Program | Development Review Engineering Team Lead  
123 NW Flanders St | Portland, OR 97209 | 📞: 503-731-8221 | 📠: 503-731-8259 | ✉: [Abraham.tayar@ODOT.state.or.us](mailto:Abraham.tayar@ODOT.state.or.us)

Work Schedule: M-TH 7:30 AM through 6:00

---

**From:** Joe Schiewe [mailto:Joe@holtgroupinc.com]  
**Sent:** Thursday, September 14, 2017 3:33 PM  
**To:** GalatiB@SherwoodOregon.gov; Jinde\_Zhu@co.washington.or.us; TAYAR Abraham \* Avi  
**Cc:** Alex Hurley; Chris Goodell; Chris Brehmer; Robinson, Michael C. (Perkins Coie); Brandt Thissell; Rian Tuttle; DANIELSON Marah B; Kelly Laustsen  
**Subject:** RE: Scoping Memo: Brookman Area Residential Development

Bob, Jinde and Avi: Please provide your review of the scoping memo for our phased development. We would like to get Kittelson started on this study as soon as we can. Thank you for your assistance.

---

**From:** Kelly Laustsen [mailto:klaustsen@kittelson.com]  
**Sent:** Thursday, September 7, 2017 11:52 AM  
**To:** [GalatiB@SherwoodOregon.gov](mailto:GalatiB@SherwoodOregon.gov); [Jinde\\_Zhu@co.washington.or.us](mailto:Jinde_Zhu@co.washington.or.us)  
**Cc:** Alex Hurley <[alex@aks-eng.com](mailto:alex@aks-eng.com)>; Joe Schiewe <[Joe@holtgroupinc.com](mailto:Joe@holtgroupinc.com)>; Chris Goodell <[chrisg@aks-eng.com](mailto:chrisg@aks-eng.com)>; Chris Brehmer <[CBREHMER@kittelson.com](mailto:CBREHMER@kittelson.com)>; Robinson, Michael C. (Perkins Coie) <[MRobinson@perkinscoie.com](mailto:MRobinson@perkinscoie.com)>; Brandt Thissell <[brandtt@aks-eng.com](mailto:brandtt@aks-eng.com)>; Rian Tuttle <[rian@holtgroupinc.com](mailto:rian@holtgroupinc.com)>; Monty Hurley <[monty@aks-eng.com](mailto:monty@aks-eng.com)>; TAYAR Abraham \* Avi <[Abraham.TAYAR@odot.state.or.us](mailto:Abraham.TAYAR@odot.state.or.us)>; DANIELSON Marah B <[Marah.B.DANIELSON@odot.state.or.us](mailto:Marah.B.DANIELSON@odot.state.or.us)>  
**Subject:** RE: Scoping Memo: Brookman Area Residential Development

Hi Bob and Jinde,

I'd like to follow-up your review of the scoping memo we prepared (attached) for the proposed residential development north of Brookman Road. Please provide any comments as soon as possible so we can move forward with the study. We appreciate your assistance.

Best,

Kelly M Laustsen, PE  
Senior Engineer

[Kittelson & Associates, Inc.](#)  
Transportation Engineering / Planning  
503.535.7439 (direct)  
214.886.5338 (cell)

**From:** Kelly Laustsen  
**Sent:** Wednesday, August 30, 2017 5:32 PM  
**To:** 'TAYAR Abraham \* Avi'; DANIELSON Marah B; [GalatiB@SherwoodOregon.gov](mailto:GalatiB@SherwoodOregon.gov); [Jinde\\_Zhu@co.washington.or.us](mailto:Jinde_Zhu@co.washington.or.us)  
**Cc:** Alex Hurley; Joe Schiewe; Chris Goodell; Chris Brehmer; Robinson, Michael C. (Perkins Coie); Brandt Thissell; Rian Tuttle; Monty Hurley  
**Subject:** RE: Scoping Memo: Brookman Area Residential Development

Avi, thank you for your review and prompt reply. We appreciate understanding your stated preference regarding use of the average rate for estimating trips associated with single family homes and townhomes. We would appreciate confirmation from the City as to their preferences as well given the other studies we have seen in the area have used the average rates.

A few observations:

- We agree the correlation coefficient is high for the fitted equations.
- Our suggestion is to continue to use the average rate for daily trip generation to maintain consistency with the County/City Transportation Development Tax which was developed based on average daily trip rates.
- We could assess the AM and PM peak hour trip generation for the single family homes and townhomes using the equation for buildout of the site. Using the peak hour equations results in a net increase of 4 AM peak hour trips and 3 PM peak hour trips, as shown in the table below.

**Trip Generation with Site Buildout**

Land Use	ITE Code	Size (units)	Weekday AM Peak Hour			Weekday PM Peak Hour		
			Total	In	Out	Total	In	Out
<b>Average Rate</b>								
Single-Family Detached Housing (AVG)	210	160	120	30	90	160	101	59
Residential Condominium/Townhouse (Average)	230	195	86	15	71	101	68	33
<b>Net New Trips (using average rate)</b>			<b>206</b>	<b>45</b>	<b>161</b>	<b>261</b>	<b>169</b>	<b>92</b>
<b>Fitted Curve Equation</b>								
Single-Family Detached Housing (AVG)	210	160	122	30	92	160	101	59
Residential Condominium/Townhouse (Average)	230	195	88	15	73	104	70	34
<b>Net New Trips (using fitted curve equation)</b>			<b>210</b>	<b>45</b>	<b>165</b>	<b>264</b>	<b>171</b>	<b>93</b>
<b>Difference in Net New Trips (fitted curve - average)</b>			<b>+4</b>	<b>0</b>	<b>+4</b>	<b>+3</b>	<b>+2</b>	<b>+1</b>

- We suggest proportionating the total trips in the table above by phase based on the ratio of homes. We don't think applying the equation by individual phases make sense – By way of example, applying the AM peak hour single family equation to a project phase with zero single family homes results in 10 trips which is clearly inappropriate (Trips = 0.70 x 0 homes + 9.74 = 9.74 trips).

Please let us know if you would like to further discuss.

Kelly M Laustsen, PE  
Senior Engineer

[Kittelson & Associates, Inc.](#)  
Transportation Engineering / Planning  
503.535.7439 (direct)  
214.886.5338 (cell)

---

**From:** TAYAR Abraham \* Avi [<mailto:Abraham.TAYAR@odot.state.or.us>]

**Sent:** Friday, August 25, 2017 5:07 PM

**To:** Kelly Laustsen; DANIELSON Marah B; [GalatiB@SherwoodOregon.gov](mailto:GalatiB@SherwoodOregon.gov); [Jinde\\_Zhu@co.washington.or.us](mailto:Jinde_Zhu@co.washington.or.us)

**Cc:** Alex Hurley; Joe Schiewe; Chris Goodell; Chris Brehmer; Robinson, Michael C. (Perkins Coie); Brandt Thissell; Rian Tuttle; Monty Hurley

**Subject:** RE: Scoping Memo: Brookman Area Residential Development

Hi Kelly,

I have reviewed your proposed Scoping Memo for the Phased Brookman Area Development and have the following comment:

Table 1. Trip Generation Estimate – The table proposes to use the “Average Rate” of the Trip Generation Manual to determine the trip generation per dwelling unit for a Single-Family Detached land use and for a Residential Condominium/Townhouse land use. In both land use cases, the Manual guides/provides a fitted Curve Equation with a very core for deviation factor that strongly support using the equations especially when multi-phased (total of 7) development over a period of 5-6 years. ODOT strongly suggest that the Fitted Curve Equations be used in both land use cases to determine Trip Generation in Table 1.

Otherwise, ODOT accept the proposed Scoping Memo once Table 1 Trip Generation Estimate is revised.

Thanks,

**Avi Tayar. P.E.** | Oregon Department of Transportation | Region 1 | Planning & Research Program | Development Review Engineering Team Lead

123 NW Flanders St | Portland, OR 97209 | 📞: 503-731-8221 | 📠: 503-731-8259 | ✉: [Abraham.tayar@ODOT.state.or.us](mailto:Abraham.tayar@ODOT.state.or.us)

Work Schedule: M-TH 7:30 AM through 6:00

---

**From:** Kelly Laustsen [<mailto:klaustsen@kittelson.com>]

**Sent:** Wednesday, August 23, 2017 5:37 PM

**To:** DANIELSON Marah B; [GalatiB@SherwoodOregon.gov](mailto:GalatiB@SherwoodOregon.gov); TAYAR Abraham \* Avi; [Jinde\\_Zhu@co.washington.or.us](mailto:Jinde_Zhu@co.washington.or.us)

**Cc:** Alex Hurley; Joe Schiewe; Chris Goodell; Chris Brehmer; Robinson, Michael C. (Perkins Coie); Brandt Thissell; Rian Tuttle; Monty Hurley

**Subject:** Scoping Memo: Brookman Area Residential Development

Dear Bob, Jinde, Avi and Marah,

We’ve developed the attached scoping memo for the proposed residential development north of Brookman Road. Please review and provide any questions, comments or additional direction. We’d appreciate your response by the end of the month.

Best,

Kelly M Laustsen, PE  
Senior Engineer

[Kittelson & Associates, Inc.](#)

Transportation Engineering / Planning

610 SW Alder St, Suite 700

Portland, Oregon 97205

503.228.5230

503.535.7439 (direct)

214.886.5338 (cell)

Appendix B  
ODOT Crash Data

OREGON DEPARTMENT OF TRANSPORTATION - TRANSPORTATION DEVELOPMENT DIVISION
TRANSPORTATION DATA SECTION - CRASH ANALYSIS AND REPORTING UNIT
CONTINUOUS SYSTEM CRASH LISTING

091 PACIFIC HIGHWAY WEST

Crashes Occurring at the Intersection of Sunset Blvd, Elwert Rd, and 99W (Pacific Hwy 91), Sherwood OR, 2012-2016

Table with columns: SER#, INVEST UNLOC?, S P D, E A U C O DATE, COUNTY CITY, RD# FC CONN #, CMPT/MLG FIRST STREET, MILEPNT SECOND STREET, LRS INTERSECTION SEQ#, RD CHAR, DIRECT, INT-TYP, (MEDIAN), INT-REL, OFFRD, WTHR, CRASH TYP, TRLR QTY, MOVE, SPCL USE, FROM, PRTC, INJ, A S, G E LICNS, PED, VEH TYPE, TO, F#, TYPE, SVRTRY, E X RES, LOC, ERROR, ACTN, EVENT, CAUSE. Contains multiple rows of crash data for various dates and locations.













OREGON DEPARTMENT OF TRANSPORTATION - TRANSPORTATION DEVELOPMENT DIVISION  
 TRANSPORTATION DATA SECTION - CRASH ANALYSIS AND REPORTING UNIT  
 CRASH SUMMARIES BY YEAR BY COLLISION TYPE

Crashes Occurring at the Intersection of Sunset Blvd and Timbrel Ln, Sherwood OR, 2012-2016

COLLISION TYPE	FATAL CRASHES	NON-FATAL CRASHES	PROPERTY DAMAGE ONLY	TOTAL CRASHES	PEOPLE KILLED	PEOPLE INJURED	TRUCKS	DRY SURF	WET SURF	DAY	DARK	INTER- SECTION	INTER- SECTION RELATED	OFF- ROAD
YEAR:														
TOTAL														
FINAL TOTAL														

**Disclaimers:** Effective 2016, collection of “Property Damage Only” (PDO) crash data elements was reduced for vehicles and participants. Age, Gender, License, Error and other elements are no longer available for PDO crash reporting. Please keep this in mind when comparing 2016 PDO crash data to prior years.

A higher number of crashes may be reported as of 2011 compared to prior years. This does not necessarily reflect an increase in annual crashes. The higher numbers may result from a change to an internal departmental process that allows the Crash Analysis and Reporting Unit to add previously unavailable , non-fatal crash reports to the annual data file. Please be aware of this change when comparing pre- 2011 crash statistics. For all disclaimers, see [https://www.oregon.gov/ODOT/Data/documents/Crash\\_Data\\_Disclaimers.pdf](https://www.oregon.gov/ODOT/Data/documents/Crash_Data_Disclaimers.pdf).

OREGON DEPARTMENT OF TRANSPORTATION - TRANSPORTATION DEVELOPMENT DIVISION  
 TRANSPORTATION DATA SECTION - CRASH ANALYSIS AND REPORTING UNIT  
 URBAN NON-SYSTEM CRASH LISTING

CITY OF SHERWOOD, WASHINGTON COUNTY

Crashes Occurring at the Intersection of Sunset Blvd, Main St, and Ladd Hill Rd, Sherwood OR, 2012-2016

SER#	S P E I N U N	D R A L C L K	R S W O H R L K	DATE	FC	CITY STREET FIRST STREET SECOND STREET INTERSECTION SEQ #	RD CHAR DIRECT LOCTN	INT-TYP (MEDIAN) LEGS (#LANES)	INT-REL TRAF- CONTL	OFF-RD RNDBT DRVWY	WTHR SURF LIGHT	CRASH TYP COLL TYP SVRTY	SPCL USE TRLR QTY OWNER V#	MOVE FROM TO	PRTC P#	INJ SVR TY	A G E	S E L I C N S	PED LOC	ERROR	ACTN	EVENT	CAUSE	
06745	N	N	N	04/20/2013	16	SW LADD HILL RD	INTER	CROSS	N	Y	CLR	FIX OBJ	01	NONE	0	TURN-L						079	08	
NO RPT				Sat 9P	0	SW SUNSET BLVD	S			N	DRY	FIX		PRVTE		E S					000	079	00	
No	45	20	59.00	-122 50 29.11		1	05	0		N	DLIT	INJ		PSNGR CAR		01	DRVR	INJB	18	M	OR-Y	001	000	08
																							OR<25	
00519	N	Y	N	N	N	01/22/2016	17	SW LADD HILL RD	INTER		CLR	ANGL-STP	01	NONE	0	TURN-R							08	
CITY				Fri 8P	0	SW SUNSET BLVD	S			N	DRY	TURN		PRVTE		W S					000		00	
No	45	20	59.00	-122 50 29.11		1	06	0		N	DLIT	INJ		PSNGR CAR		01	DRVR	NONE	44	F	OR-Y	001	000	08
																							OR<25	
													02	NONE	0	STOP						012		00
														PRVTE		S N								00
														PSNGR CAR		01	DRVR	NONE	37	M	OTH-Y	000	000	00
																							N-RES	
													03	NONE	0	STOP						012		00
														PRVTE		S N								00
														PSNGR CAR		01	DRVR	INJC	38	M	OR-Y	000	000	00
																							OR<25	
05834	N	N	N	08/30/2016	16	SW LADD HILL RD	INTER	CROSS	N	N	CLR	S-1STOP	01	NONE	9	STRGHT							29	
NONE				Tue 7A	0	SW SUNSET BLVD	W			N	DRY	REAR		N/A		W E					000		00	
No	45	20	59.00	-122 50 29.11		1	06	0		N	DAY	PDO		PSNGR CAR		01	DRVR	NONE	00	U	UNK	000	000	00
																							UNK	
																							011	00
														02	NONE	9	STOP					000	000	00
														N/A		W E								00
														PSNGR CAR		01	DRVR	NONE	00	U	UNK	000	000	00
																							UNK	
01656	N	N	N	N	N	03/30/2015	16	SW MAIN ST	INTER		CLR	S-1STOP	01	NONE	0	STRGHT							29	
CITY				Mon 7P	0	SW SUNSET BLVD	E			N	DRY	REAR		PRVTE		E W					000		00	
No	45	20	59.00	-122 50 29.11		1	06	0		N	DLIT	INJ		PSNGR CAR		01	DRVR	NONE	22	F	OR-Y	026	000	29
																							OR<25	
																							011	00
														02	NONE	0	STOP							00
														PRVTE		E W								00
														PSNGR CAR		01	DRVR	INJC	37	F	OR-Y	000	000	00
																							OR<25	
03798	N	N	N	N	N	07/07/2015	16	SW MAIN ST	INTER		CLR	O-1 L-TURN	01	NONE	0	STRGHT							02	
CITY				Tue 5P	0	SW SUNSET BLVD	CN			N	DRY	TURN		PRVTE		W E					015		00	
No	45	20	59.00	-122 50 29.11		1	03	0		N	DAY	PDO		PSNGR CAR		01	DRVR	NONE	50	F	OR-Y	000	000	00
																							OR<25	
																							015	00
														02	NONE	0	TURN-L							00
														PRVTE		E S								00
														PSNGR CAR		01	DRVR	NONE	61	F	OR-Y	004,028	000	02
																							OR<25	

OREGON DEPARTMENT OF TRANSPORTATION - TRANSPORTATION DEVELOPMENT DIVISION  
 TRANSPORTATION DATA SECTION - CRASH ANALYSIS AND REPORTING UNIT  
 CRASH SUMMARIES BY YEAR BY COLLISION TYPE

Crashes Occurring at the Intersection of Sunset Blvd, Baker Rd, and Murdock Rd, Sherwood OR, 2012-2016

COLLISION TYPE	FATAL CRASHES	NON-FATAL CRASHES	PROPERTY DAMAGE ONLY	TOTAL CRASHES	PEOPLE KILLED	PEOPLE INJURED	TRUCKS	DRY SURF	WET SURF	DAY	DARK	INTER- SECTION	INTER- SECTION RELATED	OFF- ROAD
YEAR:														
TOTAL														
FINAL TOTAL														

**Disclaimers:** Effective 2016, collection of “Property Damage Only” (PDO) crash data elements was reduced for vehicles and participants. Age, Gender, License, Error and other elements are no longer available for PDO crash reporting. Please keep this in mind when comparing 2016 PDO crash data to prior years.

A higher number of crashes may be reported as of 2011 compared to prior years. This does not necessarily reflect an increase in annual crashes. The higher numbers may result from a change to an internal departmental process that allows the Crash Analysis and Reporting Unit to add previously unavailable , non-fatal crash reports to the annual data file. Please be aware of this change when comparing pre- 2011 crash statistics. For all disclaimers, see [https://www.oregon.gov/ODOT/Data/documents/Crash\\_Data\\_Disclaimers.pdf](https://www.oregon.gov/ODOT/Data/documents/Crash_Data_Disclaimers.pdf).

OREGON DEPARTMENT OF TRANSPORTATION - TRANSPORTATION DEVELOPMENT DIVISION
TRANSPORTATION DATA SECTION - CRASH ANALYSIS AND REPORTING UNIT
CONTINUOUS SYSTEM CRASH LISTING

091 PACIFIC HIGHWAY WEST

Crashes Occurring at the Intersection of Brookman Rd Chapman Rd & OR99W (Pacific Hwy 91), Sherwood OR 2012-2016

Table with columns: SER#, INVEST UNLOC?, S D P R S W, E A U C O DATE, COUNTY, CITY, URBAN AREA, RD# FC, CMPT/MLG MILEPNT LRS, CONN #, FIRST SECOND INTERSECTION STREET STREET SEQ#, INT-TYP, RD CHAR, (MEDIAN) DIRECT, INT-REL, TRAF-LEGS, OFFRD, WTHR, RNDDBT SURF, CRASH TYP, COLL TYP, SVRTY, SPCL USE, TRLR QTY, MOVE, FROM, PRTC, INJ, SVRTY, A S, G E, LICNS, PED, LOC, ERROR, ACTN, EVENT, CAUSE.







OREGON DEPARTMENT OF TRANSPORTATION - TRANSPORTATION DEVELOPMENT DIVISION  
TRANSPORTATION DATA SECTION - CRASH ANALYSIS AND REPORTING UNIT  
CRASH SUMMARIES BY YEAR BY COLLISION TYPE

Crashes Occurring at the Intersection of Brookman Rd & Old Pacific Hwy, Sherwood OR 2012-2016

COLLISION TYPE	FATAL CRASHES	NON- FATAL CRASHES	PROPERTY DAMAGE ONLY	TOTAL CRASHES	PEOPLE KILLED	PEOPLE INJURED	TRUCKS	DRY SURF	WET SURF	DAY	DARK	INTER- SECTION	INTER- SECTION RELATED	OFF- ROAD
YEAR:														
TOTAL														
FINAL TOTAL														

**Disclaimers:** Effective 2016, collection of "Property Damage Only" (PDO) crash data elements was reduced for vehicles and participants. Age, Gender, License, Error and other elements are no longer available for PDO crash reporting. Please keep this in mind when comparing 2016 PDO crash data to prior years.

A higher number of crashes may be reported as of 2011 compared to prior years. This does not necessarily reflect an increase in annual crashes. The higher numbers may result from a change to an internal departmental process that allows the Crash Analysis and Reporting Unit to add previously unavailable , non-fatal crash reports to the annual data file. Please be aware of this change when comparing pre- 2011 crash statistics. For all disclaimers, see [https://www.oregon.gov/ODOT/Data/documents/Crash\\_Data\\_Disclaimers.pdf](https://www.oregon.gov/ODOT/Data/documents/Crash_Data_Disclaimers.pdf).



OREGON DEPARTMENT OF TRANSPORTATION - TRANSPORTATION DEVELOPMENT DIVISION  
 TRANSPORTATION DATA SECTION - CRASH ANALYSIS AND REPORTING UNIT  
 CRASH SUMMARIES BY YEAR BY COLLISION TYPE

Crashes Occurring at the Intersection of Brookman Rd & Oberst Rd, Sherwood OR, 2012-2016

COLLISION TYPE	FATAL CRASHES	NON-FATAL CRASHES	PROPERTY DAMAGE ONLY	TOTAL CRASHES	PEOPLE KILLED	PEOPLE INJURED	TRUCKS	DRY SURF	WET SURF	DAY	DARK	INTER- SECTION	INTER- SECTION RELATED	OFF- ROAD
YEAR:														
TOTAL														
FINAL TOTAL														

**Disclaimers:** Effective 2016, collection of “Property Damage Only” (PDO) crash data elements was reduced for vehicles and participants. Age, Gender, License, Error and other elements are no longer available for PDO crash reporting. Please keep this in mind when comparing 2016 PDO crash data to prior years.

A higher number of crashes may be reported as of 2011 compared to prior years. This does not necessarily reflect an increase in annual crashes. The higher numbers may result from a change to an internal departmental process that allows the Crash Analysis and Reporting Unit to add previously unavailable , non-fatal crash reports to the annual data file. Please be aware of this change when comparing pre- 2011 crash statistics. For all disclaimers, see [https://www.oregon.gov/ODOT/Data/documents/Crash\\_Data\\_Disclaimers.pdf](https://www.oregon.gov/ODOT/Data/documents/Crash_Data_Disclaimers.pdf).

OREGON DEPARTMENT OF TRANSPORTATION - TRANSPORTATION DEVELOPMENT DIVISION  
 TRANSPORTATION DATA SECTION - CRASH ANALYSIS AND REPORTING UNIT  
 CRASH SUMMARIES BY YEAR BY COLLISION TYPE

Crashes Occurring at the Intersection of Brookman Rd & Ladd Hill Rd, Sherwood OR 2012-2016

COLLISION TYPE	FATAL CRASHES	NON-FATAL CRASHES	PROPERTY DAMAGE ONLY	TOTAL CRASHES	PEOPLE KILLED	PEOPLE INJURED	TRUCKS	DRY SURF	WET SURF	DAY	DARK	INTER- SECTION	INTER- SECTION RELATED	OFF- ROAD
YEAR:														
TOTAL														
FINAL TOTAL														

**Disclaimers:** Effective 2016, collection of “Property Damage Only” (PDO) crash data elements was reduced for vehicles and participants. Age, Gender, License, Error and other elements are no longer available for PDO crash reporting. Please keep this in mind when comparing 2016 PDO crash data to prior years.

A higher number of crashes may be reported as of 2011 compared to prior years. This does not necessarily reflect an increase in annual crashes. The higher numbers may result from a change to an internal departmental process that allows the Crash Analysis and Reporting Unit to add previously unavailable , non-fatal crash reports to the annual data file. Please be aware of this change when comparing pre- 2011 crash statistics. For all disclaimers, see [https://www.oregon.gov/ODOT/Data/documents/Crash\\_Data\\_Disclaimers.pdf](https://www.oregon.gov/ODOT/Data/documents/Crash_Data_Disclaimers.pdf).

ACTION CODE TRANSLATION LIST

ACTION CODE	SHORT DESCRIPTION	LONG DESCRIPTION
000	NONE	NO ACTION OR NON-WARRANTED
001	SKIDDED	SKIDDED
002	ON/OFF V	GETTING ON OR OFF STOPPED OR PARKED VEHICLE
003	LOAD OVR	OVERHANGING LOAD STRUCK ANOTHER VEHICLE, ETC.
006	SLOW DN	SLOWED DOWN
007	AVOIDING	AVOIDING MANEUVER
008	PAR PARK	PARALLEL PARKING
009	ANG PARK	ANGLE PARKING
010	INTERFERE	PASSENGER INTERFERING WITH DRIVER
011	STOPPED	STOPPED IN TRAFFIC NOT WAITING TO MAKE A LEFT TURN
012	STP/L TRN	STOPPED BECAUSE OF LEFT TURN SIGNAL OR WAITING, ETC.
013	STP TURN	STOPPED WHILE EXECUTING A TURN
014	EMR V PKD	EMERGENCY VEHICLE LEGALLY PARKED IN THE ROADWAY
015	GO A/STOP	PROCEED AFTER STOPPING FOR A STOP SIGN/FLASHING RED.
016	TRN A/RED	TURNED ON RED AFTER STOPPING
017	LOSTCTRL	LOST CONTROL OF VEHICLE
018	EXIT DWY	ENTERING STREET OR HIGHWAY FROM ALLEY OR DRIVEWAY
019	ENTR DWY	ENTERING ALLEY OR DRIVEWAY FROM STREET OR HIGHWAY
020	STR ENTR	BEFORE ENTERING ROADWAY, STRUCK PEDESTRIAN, ETC. ON SIDEWALK OR SHOULDER
021	NO DRVR	CAR RAN AWAY - NO DRIVER
022	PREV COL	STRUCK, OR WAS STRUCK BY, VEHICLE OR PEDESTRIAN IN PRIOR COLLISION BEFORE ACC. STABILIZED
023	STALLED	VEHICLE STALLED OR DISABLED
024	DRVR DEAD	DEAD BY UNASSOCIATED CAUSE
025	FATIGUE	FATIGUED, SLEEPY, ASLEEP
026	SUN	DRIVER BLINDED BY SUN
027	HDLGHTS	DRIVER BLINDED BY HEADLIGHTS
028	ILLNESS	PHYSICALLY ILL
029	THRU MED	VEHICLE CROSSED, PLUNGED OVER, OR THROUGH MEDIAN BARRIER
030	PURSUIT	PURSuing OR ATTEMPTING TO STOP A VEHICLE
031	PASSING	PASSING SITUATION
032	PRKOFFRD	VEHICLE PARKED BEYOND CURB OR SHOULDER
033	CROS MED	VEHICLE CROSSED EARTH OR GRASS MEDIAN
034	X N/SGNL	CROSSING AT INTERSECTION - NO TRAFFIC SIGNAL PRESENT
035	X W/ SGNL	CROSSING AT INTERSECTION - TRAFFIC SIGNAL PRESENT
036	DIAGONAL	CROSSING AT INTERSECTION - DIAGONALLY
037	BTWN INT	CROSSING BETWEEN INTERSECTIONS
038	DISTRACT	DRIVER'S ATTENTION DISTRACTED
039	W/TRAF-S	WALKING, RUNNING, RIDING, ETC., ON SHOULDER WITH TRAFFIC
040	A/TRAF-S	WALKING, RUNNING, RIDING, ETC., ON SHOULDER FACING TRAFFIC
041	W/TRAF-P	WALKING, RUNNING, RIDING, ETC., ON PAVEMENT WITH TRAFFIC
042	A/TRAF-P	WALKING, RUNNING, RIDING, ETC., ON PAVEMENT FACING TRAFFIC
043	PLAYINRD	PLAYING IN STREET OR ROAD
044	PUSH MV	PUSHING OR WORKING ON VEHICLE IN ROAD OR ON SHOULDER
045	WORK ON	WORKING IN ROADWAY OR ALONG SHOULDER
046	W/ TRAFIC	NON-MOTORIST WALKING, RUNNING, RIDING, ETC. WITH TRAFFIC
047	A/ TRAFIC	NON-MOTORIST WALKING, RUNNING, RIDING, ETC. FACING TRAFFIC
050	LAY ON RD	STANDING OR LYING IN ROADWAY
051	ENT OFFRD	ENTERING / STARTING IN TRAFFIC LANE FROM OFF ROAD
052	MERGING	MERGING

ACTION CODE TRANSLATION LIST

ACTION CODE	SHORT DESCRIPTION	LONG DESCRIPTION
055	SPRAY	BLINDED BY WATER SPRAY
088	OTHER	OTHER ACTION
099	UNK	UNKNOWN ACTION



CAUSE CODE TRANSLATION LIST

CAUSE CODE	SHORT DESCRIPTION	LONG DESCRIPTION
00	NO CODE	NO CAUSE ASSOCIATED AT THIS LEVEL
01	TOO-FAST	TOO FAST FOR CONDITIONS (NOT EXCEED POSTED SPEED
02	NO-YIELD	DID NOT YIELD RIGHT-OF-WAY
03	PAS-STOP	PASSED STOP SIGN OR RED FLASHER
04	DIS SIG	DISREGARDED TRAFFIC SIGNAL
05	LEFT-CTR	DROVE LEFT OF CENTER ON TWO-WAY ROAD; STRADDLING
06	IMP-OVER	IMPROPER OVERTAKING
07	TOO-CLOS	FOLLOWED TOO CLOSELY
08	IMP-TURN	MADE IMPROPER TURN
09	DRINKING	ALCOHOL OR DRUG INVOLVED
10	OTHR-IMP	OTHER IMPROPER DRIVING
11	MECH-DEF	MECHANICAL DEFECT
12	OTHER	OTHER (NOT IMPROPER DRIVING)
13	IMP LN C	IMPROPER CHANGE OF TRAFFIC LANES
14	DIS TCD	DISREGARDED OTHER TRAFFIC CONTROL DEVICE
15	WRNG WAY	WRONG WAY ON ONE-WAY ROAD; WRONG SIDE DIVIDED RO
16	FATIGUE	DRIVER DROWSY/FATIGUED/SLEEPY
17	ILLNESS	PHYSICAL ILLNESS
18	IN RDWY	NON-MOTORIST ILLEGALLY IN ROADWAY
19	NT VISBL	NON-MOTORIST NOT VISIBLE; NON-REFLECTIVE CLOTHIN
20	IMP PKNG	VEHICLE IMPROPERLY PARKED
21	DEF STER	DEFECTIVE STEERING MECHANISM
22	DEF BRKE	INADEQUATE OR NO BRAKES
24	LOADSHFT	VEHICLE LOST LOAD OR LOAD SHIFTED
25	TIREFAIL	TIRE FAILURE
26	PHANTOM	PHANTOM / NON-CONTACT VEHICLE
27	INATTENT	INATTENTION
28	NM INATT	NON-MOTORIST INATTENTION
29	F AVOID	FAILED TO AVOID VEHICLE AHEAD
30	SPEED	DRIVING IN EXCESS OF POSTED SPEED
31	RACING	SPEED RACING (PER PAR)
32	CARELESS	CARELESS DRIVING (PER PAR)
33	RECKLESS	RECKLESS DRIVING (PER PAR)
34	AGGRESV	AGGRESSIVE DRIVING (PER PAR)
35	RD RAGE	ROAD RAGE (PER PAR)
40	VIEW OBS	VIEW OBSCURED
50	USED MDN	IMPROPER USE OF MEDIAN OR SHOULDER
51	FAIL LN	FAILED TO MAINTAIN LANE
52	OFF RD	RAN OFF ROAD

COLLISION TYPE CODE TRANSLATION LIST

COLL CODE	SHORT DESCRIPTION	LONG DESCRIPTION
&	OTH	MISCELLANEOUS
-	BACK	BACKING
0	PED	PEDESTRIAN
1	ANGL	ANGLE
2	HEAD	HEAD-ON
3	REAR	REAR-END
4	SS-M	SIDESWIPE - MEETING
5	SS-O	SIDESWIPE - OVERTAKING
6	TURN	TURNING MOVEMENT
7	PARK	PARKING MANEUVER
8	NCOL	NON-COLLISION
9	FIX	FIXED OBJECT OR OTHER OBJECT

CRASH TYPE CODE TRANSLATION LIST

CRASH TYPE	SHORT DESCRIPTION	LONG DESCRIPTION
&	OVERTURN	OVERTURNED
0	NON-COLL	OTHER NON-COLLISION
1	OTH RDWY	MOTOR VEHICLE ON OTHER ROADWAY
2	PRKD MV	PARKED MOTOR VEHICLE
3	PED	PEDESTRIAN
4	TRAIN	RAILWAY TRAIN
6	BIKE	PEDALCYCLIST
7	ANIMAL	ANIMAL
8	FIX OBJ	FIXED OBJECT
9	OTH OBJ	OTHER OBJECT
A	ANGL-STP	ENTERING AT ANGLE - ONE VEHICLE STOPPED
B	ANGL-OTH	ENTERING AT ANGLE - ALL OTHERS
C	S-STRGHT	FROM SAME DIRECTION - BOTH GOING STRAIGHT
D	S-1TURN	FROM SAME DIRECTION - ONE TURN, ONE STRAIGHT
E	S-1STOP	FROM SAME DIRECTION - ONE STOPPED
F	S-OTHER	FROM SAME DIRECTION-ALL OTHERS, INCLUDING PARKING
G	O-STRGHT	FROM OPPOSITE DIRECTION - BOTH GOING STRAIGHT
H	O-1 L-TURN	FROM OPPOSITE DIRECTION-ONE LEFT TURN, ONE STRAIGHT
I	O-1STOP	FROM OPPOSITE DIRECTION - ONE STOPPED
J	O-OTHER	FROM OPPOSITE DIRECTION-ALL OTHERS INCL. PARKING

DRIVER LICENSE CODE TRANSLATION LIST

LIC CODE	SHORT DESC	LONG DESCRIPTION
0	NONE	NOT LICENSED (HAD NEVER BEEN LICENSED)
1	OR-Y	VALID OREGON LICENSE
2	OTH-Y	VALID LICENSE, OTHER STATE OR COUNTRY
3	SUSP	SUSPENDED/REVOKED
4	EXP	EXPIRED
8	N-VAL	OTHER NON-VALID LICENSE
9	UNK	UNKNOWN IF DRIVER WAS LICENSED AT TIME OF CRASH

DRIVER RESIDENCE CODE TRANSLATION LIST

RES CODE	SHORT DESC	LONG DESCRIPTION
1	OR<25	OREGON RESIDENT WITHIN 25 MILE OF HOME
2	OR>25	OREGON RESIDENT 25 OR MORE MILES FROM HOME
3	OR-?	OREGON RESIDENT - UNKNOWN DISTANCE FROM HOME
4	N-RES	NON-RESIDENT
9	UNK	UNKNOWN IF OREGON RESIDENT

ERROR CODE TRANSLATION LIST

ERROR CODE	SHORT DESCRIPTION	FULL DESCRIPTION
000	NONE	NO ERROR
001	WIDE TRN	WIDE TURN
002	CUT CORN	CUT CORNER ON TURN
003	FAIL TRN	FAILED TO OBEY MANDATORY TRAFFIC TURN SIGNAL, SIGN OR LANE MARKINGS
004	L IN TRF	LEFT TURN IN FRONT OF ONCOMING TRAFFIC
005	L PROHIB	LEFT TURN WHERE PROHIBITED
006	FRM WRNG	TURNEED FROM WRONG LANE
007	TO WRONG	TURNEED INTO WRONG LANE
008	ILLEG U	U-TURNEED ILLEGALLY
009	IMP STOP	IMPROPERLY STOPPED IN TRAFFIC LANE
010	IMP SIG	IMPROPER SIGNAL OR FAILURE TO SIGNAL
011	IMP BACK	BACKING IMPROPERLY (NOT PARKING)
012	IMP PARK	IMPROPERLY PARKED
013	UNPARK	IMPROPER START LEAVING PARKED POSITION
014	IMP STRT	IMPROPER START FROM STOPPED POSITION
015	IMP LGHT	IMPROPER OR NO LIGHTS (VEHICLE IN TRAFFIC)
016	INATTENT	INATTENTION (FAILURE TO DIM LIGHTS PRIOR TO 4/1/97)
017	UNSF VEH	DRIVING UNSAFE VEHICLE (NO OTHER ERROR APPARENT)
018	OTH PARK	ENTERING/EXITING PARKED POSITION W/ INSUFFICIENT CLEARANCE; OTHER IMPROPER PARKING MANEUVER
019	DIS DRIV	DISREGARDED OTHER DRIVER'S SIGNAL
020	DIS SGNL	DISREGARDED TRAFFIC SIGNAL
021	RAN STOP	DISREGARDED STOP SIGN OR FLASHING RED
022	DIS SIGN	DISREGARDED WARNING SIGN, FLARES OR FLASHING AMBER
023	DIS OFCR	DISREGARDED POLICE OFFICER OR FLAGMAN
024	DIS EMER	DISREGARDED SIREN OR WARNING OF EMERGENCY VEHICLE
025	DIS RR	DISREGARDED RR SIGNAL, RR SIGN, OR RR FLAGMAN
026	REAR-END	FAILED TO AVOID STOPPED OR PARKED VEHICLE AHEAD OTHER THAN SCHOOL BUS
027	BIKE ROW	DID NOT HAVE RIGHT-OF-WAY OVER PEDALCYCLIST
028	NO ROW	DID NOT HAVE RIGHT-OF-WAY
029	PED ROW	FAILED TO YIELD RIGHT-OF-WAY TO PEDESTRIAN
030	PAS CURV	PASSING ON A CURVE
031	PAS WRNG	PASSING ON THE WRONG SIDE
032	PAS TANG	PASSING ON STRAIGHT ROAD UNDER UNSAFE CONDITIONS
033	PAS X-WK	PASSED VEHICLE STOPPED AT CROSSWALK FOR PEDESTRIAN
034	PAS INTR	PASSING AT INTERSECTION
035	PAS HILL	PASSING ON CREST OF HILL
036	N/PAS ZN	PASSING IN "NO PASSING" ZONE
037	PAS TRAF	PASSING IN FRONT OF ONCOMING TRAFFIC
038	CUT-IN	CUTTING IN (TWO LANES - TWO WAY ONLY)
039	WRNGSIDE	DRIVING ON WRONG SIDE OF THE ROAD (2-WAY UNDIVIDED ROADWAYS)

ERROR CODE TRANSLATION LIST

ERROR CODE	SHORT DESCRIPTION	FULL DESCRIPTION
040	THRU MED	DRIVING THROUGH SAFETY ZONE OR OVER ISLAND
041	F/ST BUS	FAILED TO STOP FOR SCHOOL BUS
042	F/SLO MV	FAILED TO DECREASE SPEED FOR SLOWER MOVING VEHICLE
043	TOO CLOSE	FOLLOWING TOO CLOSELY (MUST BE ON OFFICER'S REPORT)
044	STRDL LN	STRADDLING OR DRIVING ON WRONG LANES
045	IMP CHG	IMPROPER CHANGE OF TRAFFIC LANES
046	WRNG WAY	WRONG WAY ON ONE-WAY ROADWAY; WRONG SIDE DIVIDED ROAD
047	BASCRULE	DRIVING TOO FAST FOR CONDITIONS (NOT EXCEEDING POSTED SPEED)
048	OPN DOOR	OPENED DOOR INTO ADJACENT TRAFFIC LANE
049	IMPEDING	IMPEDING TRAFFIC
050	SPEED	DRIVING IN EXCESS OF POSTED SPEED
051	RECKLESS	RECKLESS DRIVING (PER PAR)
052	CARELESS	CARELESS DRIVING (PER PAR)
053	RACING	SPEED RACING (PER PAR)
054	X N/SGNL	CROSSING AT INTERSECTION, NO TRAFFIC SIGNAL PRESENT
055	X W/SGNL	CROSSING AT INTERSECTION, TRAFFIC SIGNAL PRESENT
056	DIAGONAL	CROSSING AT INTERSECTION - DIAGONALLY
057	BTWN INT	CROSSING BETWEEN INTERSECTIONS
059	W/TRAF-S	WALKING, RUNNING, RIDING, ETC., ON SHOULDER WITH TRAFFIC
060	A/TRAF-S	WALKING, RUNNING, RIDING, ETC., ON SHOULDER FACING TRAFFIC
061	W/TRAF-P	WALKING, RUNNING, RIDING, ETC., ON PAVEMENT WITH TRAFFIC
062	A/TRAF-P	WALKING, RUNNING, RIDING, ETC., ON PAVEMENT FACING TRAFFIC
063	PLAYINRD	PLAYING IN STREET OR ROAD
064	PUSH MV	PUSHING OR WORKING ON VEHICLE IN ROAD OR ON SHOULDER
065	WORK IN RD	WORKING IN ROADWAY OR ALONG SHOULDER
070	LAY ON RD	STANDING OR LYING IN ROADWAY
071	NM IMP USE	IMPROPER USE OF TRAFFIC LANE BY NON-MOTORIST
073	ELUDING	ELUDING / ATTEMPT TO ELUDE
079	F NEG CURV	FAILED TO NEGOTIATE A CURVE
080	FAIL LN	FAILED TO MAINTAIN LANE
081	OFF RD	RAN OFF ROAD
082	NO CLEAR	DRIVER MISJUDGED CLEARANCE
083	OVRSTEER	OVER-CORRECTING
084	NOT USED	CODE NOT IN USE
085	OVRLOAD	OVERLOADING OR IMPROPER LOADING OF VEHICLE WITH CARGO OR PASSENGERS
097	UNA DIS TC	UNABLE TO DETERMINE WHICH DRIVER DISREGARDED TRAFFIC CONTROL DEVICE

## EVENT CODE TRANSLATION LIST

EVENT CODE	SHORT DESCRIPTION	LONG DESCRIPTION
001	FEL/JUMP	OCCUPANT FELL, JUMPED OR WAS EJECTED FROM MOVING VEHICLE
002	INTERFER	PASSENGER INTERFERED WITH DRIVER
003	BUG INTF	ANIMAL OR INSECT IN VEHICLE INTERFERED WITH DRIVER
004	INDRCT PED	PEDESTRIAN INDIRECTLY INVOLVED (NOT STRUCK)
005	SUB-PED	"SUB-PED": PEDESTRIAN INJURED SUBSEQUENT TO COLLISION, ETC.
006	INDRCT BIK	PEDALCYCLIST INDIRECTLY INVOLVED (NOT STRUCK)
007	HITCHIKR	HITCHHIKER (SOLICITING A RIDE)
008	PSNGR TOW	PASSENGER OR NON-MOTORIST BEING TOWED OR PUSHED ON CONVEYANCE
009	ON/OFF V	GETTING ON/OFF STOPPED/PARKED VEHICLE (OCCUPANTS ONLY; MUST HAVE PHYSICAL CONTACT W/ VEHICLE)
010	SUB OTRN	OVERTURNED AFTER FIRST HARMFUL EVENT
011	MV PUSHD	VEHICLE BEING PUSHED
012	MV TOWED	VEHICLE TOWED OR HAD BEEN TOWING ANOTHER VEHICLE
013	FORCED	VEHICLE FORCED BY IMPACT INTO ANOTHER VEHICLE, PEDALCYCLIST OR PEDESTRIAN
014	SET MOTN	VEHICLE SET IN MOTION BY NON-DRIVER (CHILD RELEASED BRAKES, ETC.)
015	RR ROW	AT OR ON RAILROAD RIGHT-OF-WAY (NOT LIGHT RAIL)
016	LT RL ROW	AT OR ON LIGHT-RAIL RIGHT-OF-WAY
017	RR HIT V	TRAIN STRUCK VEHICLE
018	V HIT RR	VEHICLE STRUCK TRAIN
019	HIT RR CAR	VEHICLE STRUCK RAILROAD CAR ON ROADWAY
020	JACKKNIFE	JACKKNIFE; TRAILER OR TOWED VEHICLE STRUCK TOWING VEHICLE
021	TRL OTRN	TRAILER OR TOWED VEHICLE OVERTURNED
022	CN BROKE	TRAILER CONNECTION BROKE
023	DETACH TRL	DETACHED TRAILING OBJECT STRUCK OTHER VEHICLE, NON-MOTORIST, OR OBJECT
024	V DOOR OPN	VEHICLE DOOR OPENED INTO ADJACENT TRAFFIC LANE
025	WHEELOFF	WHEEL CAME OFF
026	HOOD UP	HOOD FLEW UP
028	LOAD SHIFT	LOST LOAD, LOAD MOVED OR SHIFTED
029	TIREFAIL	TIRE FAILURE
030	PET	PET: CAT, DOG AND SIMILAR
031	LVSTOCK	STOCK: COW, CALF, BULL, STEER, SHEEP, ETC.
032	HORSE	HORSE, MULE, OR DONKEY
033	HRSE&RID	HORSE AND RIDER
034	GAME	WILD ANIMAL, GAME (INCLUDES BIRDS; NOT DEER OR ELK)
035	DEER ELK	DEER OR ELK, WAPITI
036	ANML VEH	ANIMAL-DRAWN VEHICLE
037	CULVERT	CULVERT, OPEN LOW OR HIGH MANHOLE
038	ATENUATN	IMPACT ATTENUATOR
039	PK METER	PARKING METER
040	CURB	CURB (ALSO NARROW SIDEWALKS ON BRIDGES)
041	JIGGLE	JIGGLE BAR OR TRAFFIC SNAKE FOR CHANNELIZATION
042	GDRL END	LEADING EDGE OF GUARDRAIL
043	GARDRAIL	GUARD RAIL (NOT METAL MEDIAN BARRIER)
044	BARRIER	MEDIAN BARRIER (RAISED OR METAL)
045	WALL	RETAINING WALL OR TUNNEL WALL
046	BR RAIL	BRIDGE RAILING OR PARAPET (ON BRIDGE OR APPROACH)
047	BR ABUTMNT	BRIDGE ABUTMENT (INCLUDED "APPROACH END" THRU 2013)
048	BR COLMN	BRIDGE PILLAR OR COLUMN
049	BR GIRDR	BRIDGE GIRDER (HORIZONTAL BRIDGE STRUCTURE OVERHEAD)
050	ISLAND	TRAFFIC RAISED ISLAND
051	GORE	GORE
052	POLE UNK	POLE - TYPE UNKNOWN
053	POLE UTL	POLE - POWER OR TELEPHONE
054	ST LIGHT	POLE - STREET LIGHT ONLY
055	TRF SGNL	POLE - TRAFFIC SIGNAL AND PED SIGNAL ONLY
056	SGN BRDG	POLE - SIGN BRIDGE
057	STOPSIGN	STOP OR YIELD SIGN

## EVENT CODE TRANSLATION LIST

EVENT CODE	SHORT DESCRIPTION	LONG DESCRIPTION
058	OTH SIGN	OTHER SIGN, INCLUDING STREET SIGNS
059	HYDRANT	HYDRANT
060	MARKER	DELINEATOR OR MARKER (REFLECTOR POSTS)
061	MAILBOX	MAILBOX
062	TREE	TREE, STUMP OR SHRUBS
063	VEG OHED	TREE BRANCH OR OTHER VEGETATION OVERHEAD, ETC.
064	WIRE/CBL	WIRE OR CABLE ACROSS OR OVER THE ROAD
065	TEMP SGN	TEMPORARY SIGN OR BARRICADE IN ROAD, ETC.
066	PERM SGN	PERMANENT SIGN OR BARRICADE IN/OFF ROAD
067	SLIDE	SLIDES, FALLEN OR FALLING ROCKS
068	FRGN OBJ	FOREIGN OBSTRUCTION/DEBRIS IN ROAD (NOT GRAVEL)
069	EQP WORK	EQUIPMENT WORKING IN/OFF ROAD
070	OTH EQP	OTHER EQUIPMENT IN OR OFF ROAD (INCLUDES PARKED TRAILER, BOAT)
071	MAIN EQP	WRECKER, STREET SWEEPER, SNOW PLOW OR SANDING EQUIPMENT
072	OTHER WALL	ROCK, BRICK OR OTHER SOLID WALL
073	IRRGL PVMT	OTHER BUMP (NOT SPEED BUMP), POTHOLE OR PAVEMENT IRREGULARITY (PER PAR)
074	OVERHD OBJ	OTHER OVERHEAD OBJECT (HIGHWAY SIGN, SIGNAL HEAD, ETC.); NOT BRIDGE
075	CAVE IN	BRIDGE OR ROAD CAVE IN
076	HI WATER	HIGH WATER
077	SNO BANK	SNOW BANK
078	LO-HI EDGE	LOW OR HIGH SHOULDER AT PAVEMENT EDGE
079	DITCH	CUT SLOPE OR DITCH EMBANKMENT
080	OBJ FRM MV	STRUCK BY ROCK OR OTHER OBJECT SET IN MOTION BY OTHER VEHICLE (INCL. LOST LOADS)
081	FLY-OBJ	STRUCK BY ROCK OR OTHER MOVING OR FLYING OBJECT (NOT SET IN MOTION BY VEHICLE)
082	VEH HID	VEHICLE OBSCURED VIEW
083	VEG HID	VEGETATION OBSCURED VIEW
084	BLDG HID	VIEW OBSCURED BY FENCE, SIGN, PHONE BOOTH, ETC.
085	WIND GUST	WIND GUST
086	IMMERSED	VEHICLE IMMERSED IN BODY OF WATER
087	FIRE/EXP	FIRE OR EXPLOSION
088	FENC/BLD	FENCE OR BUILDING, ETC.
089	OTHR CRASH	CRASH RELATED TO ANOTHER SEPARATE CRASH
090	TO 1 SIDE	TWO-WAY TRAFFIC ON DIVIDED ROADWAY ALL ROUTED TO ONE SIDE
091	BUILDING	BUILDING OR OTHER STRUCTURE
092	PHANTOM	OTHER (PHANTOM) NON-CONTACT VEHICLE
093	CELL PHONE	CELL PHONE (ON PAR OR DRIVER IN USE)
094	VIOL GDL	TEENAGE DRIVER IN VIOLATION OF GRADUATED LICENSE PGM
095	GUY WIRE	GUY WIRE
096	BERM	BERM (EARTHEN OR GRAVEL MOUND)
097	GRAVEL	GRAVEL IN ROADWAY
098	ABR EDGE	ABRUPT EDGE
099	CELL WTNSD	CELL PHONE USE WITNESSED BY OTHER PARTICIPANT
100	UNK FIXD	FIXED OBJECT, UNKNOWN TYPE.
101	OTHER OBJ	NON-FIXED OBJECT, OTHER OR UNKNOWN TYPE
102	TEXTING	TEXTING
103	WZ WORKER	WORK ZONE WORKER
104	ON VEHICLE	PASSENGER RIDING ON VEHICLE EXTERIOR
105	PEDAL PSGR	PASSENGER RIDING ON PEDALCYCLE
106	MAN WHLCHR	PEDESTRIAN IN NON-MOTORIZED WHEELCHAIR
107	MTR WHLCHR	PEDESTRIAN IN MOTORIZED WHEELCHAIR
108	OFFICER	LAW ENFORCEMENT / POLICE OFFICER
109	SUB-BIKE	"SUB-BIKE": PEDALCYCLIST INJURED SUBSEQUENT TO COLLISION, ETC.
110	N-MTR	NON-MOTORIST STRUCK VEHICLE
111	S CAR VS V	STREET CAR/TROLLEY (ON RAILS OR OVERHEAD WIRE SYSTEM) STRUCK VEHICLE
112	V VS S CAR	VEHICLE STRUCK STREET CAR/TROLLEY (ON RAILS OR OVERHEAD WIRE SYSTEM)
113	S CAR ROW	AT OR ON STREET CAR OR TROLLEY RIGHT-OF-WAY

EVENT CODE TRANSLATION LIST

EVENT CODE	SHORT DESCRIPTION	LONG DESCRIPTION
114	RR EQUIP	VEHICLE STRUCK RAILROAD EQUIPMENT (NOT TRAIN) ON TRACKS
115	DSTRCT GPS	DISTRACTED BY NAVIGATION SYSTEM OR GPS DEVICE
116	DSTRCT OTH	DISTRACTED BY OTHER ELECTRONIC DEVICE
117	RR GATE	RAIL CROSSING DROP-ARM GATE
118	EXPNSN JNT	EXPANSION JOINT
119	JERSEY BAR	JERSEY BARRIER
120	WIRE BAR	WIRE OR CABLE MEDIAN BARRIER
121	FENCE	FENCE
123	OBJ IN VEH	LOOSE OBJECT IN VEHICLE STRUCK OCCUPANT
124	SLIPPERY	SLIDING OR SWERVING DUE TO WET, ICY, SLIPPERY OR LOOSE SURFACE (NOT GRAVEL)
125	SHLDR	SHOULDER GAVE WAY
126	BOULDER	ROCK(S), BOULDER (NOT GRAVEL; NOT ROCK SLIDE)
127	LAND SLIDE	ROCK SLIDE OR LAND SLIDE
128	CURVE INV	CURVE PRESENT AT CRASH LOCATION
129	HILL INV	VERTICAL GRADE / HILL PRESENT AT CRASH LOCATION
130	CURVE HID	VIEW OBSCURED BY CURVE
131	HILL HID	VIEW OBSCURED BY VERTICAL GRADE / HILL
132	WINDOW HID	VIEW OBSCURED BY VEHICLE WINDOW CONDITIONS
133	SPRAY HID	VIEW OBSCURED BY WATER SPRAY
134	TORRENTIAL	TORRENTIAL RAIN (EXCEPTIONALLY HEAVY RAIN)

FUNCTIONAL CLASSIFICATION TRANSLATION LIST

FUNC CLASS	DESCRIPTION
01	RURAL PRINCIPAL ARTERIAL - INTERSTATE
02	RURAL PRINCIPAL ARTERIAL - OTHER
06	RURAL MINOR ARTERIAL
07	RURAL MAJOR COLLECTOR
08	RURAL MINOR COLLECTOR
09	RURAL LOCAL
11	URBAN PRINCIPAL ARTERIAL - INTERSTATE
12	URBAN PRINCIPAL ARTERIAL - OTHER FREEWAYS AND EXP
14	URBAN PRINCIPAL ARTERIAL - OTHER
16	URBAN MINOR ARTERIAL
17	URBAN MAJOR COLLECTOR
18	URBAN MINOR COLLECTOR
19	URBAN LOCAL
78	UNKNOWN RURAL SYSTEM
79	UNKNOWN RURAL NON-SYSTEM
98	UNKNOWN URBAN SYSTEM
99	UNKNOWN URBAN NON-SYSTEM

HIGHWAY COMPONENT TRANSLATION LIST

CODE	DESCRIPTION
0	MAINLINE STATE HIGHWAY
1	COUplet
3	FRONTAGE ROAD
6	CONNECTION
8	HIGHWAY - OTHER

INJURY SEVERITY CODE TRANSLATION LIST

CODE	SHORT DESC	LONG DESCRIPTION
1	KILL	FATAL INJURY
2	INJA	INCAPACITATING INJURY - BLEEDING, BROKEN BONES
3	INJB	NON-INCAPACITATING INJURY
4	INJC	POSSIBLE INJURY - COMPLAINT OF PAIN
5	PRI	DIED PRIOR TO CRASH
7	NO<5	NO INJURY - 0 TO 4 YEARS OF AGE
9	NONE	PARTICIPANT UNINJURED, OVER THE AGE OF 4

LIGHT CONDITION CODE TRANSLATION LIST

CODE	SHORT DESC	LONG DESCRIPTION
0	UNK	UNKNOWN
1	DAY	DAYLIGHT
2	DLIT	DARKNESS - WITH STREET LIGHTS
3	DARK	DARKNESS - NO STREET LIGHTS
4	DAWN	DAWN (TWILIGHT)
5	DUSK	DUSK (TWILIGHT)

MEDIAN TYPE CODE TRANSLATION LIST

CODE	SHORT DESC	LONG DESCRIPTION
0	NONE	NO MEDIAN
1	RSDMD	SOLID MEDIAN BARRIER
2	DIVMD	EARTH, GRASS OR PAVED MEDIAN

MILEAGE TYPE CODE TRANSLATION LIST

CODE	LONG DESCRIPTION
0	REGULAR MILEAGE
T	TEMPORARY
Y	SPUR
Z	OVERLAPPING

**MOVEMENT TYPE CODE TRANSLATION LIST**

CODE	SHORT DESC	LONG DESCRIPTION
0	UNK	UNKNOWN
1	STRGHT	STRAIGHT AHEAD
2	TURN-R	TURNING RIGHT
3	TURN-L	TURNING LEFT
4	U-TURN	MAKING A U-TURN
5	BACK	BACKING
6	STOP	STOPPED IN TRAFFIC
7	PRKD-P	PARKED - PROPERLY
8	PRKD-I	PARKED - IMPROPERLY
9	PARKNG	PARKING MANEUVER

**NON-MOTORIST LOCATION CODE TRANSLATION LIST**

CODE	LONG DESCRIPTION
00	AT INTERSECTION - NOT IN ROADWAY
01	AT INTERSECTION - INSIDE CROSSWALK
02	AT INTERSECTION - IN ROADWAY, OUTSIDE CROSSWALK
03	AT INTERSECTION - IN ROADWAY, XWALK AVAIL UNKNWN
04	NOT AT INTERSECTION - IN ROADWAY
05	NOT AT INTERSECTION - ON SHOULDER
06	NOT AT INTERSECTION - ON MEDIAN
07	NOT AT INTERSECTION - WITHIN TRAFFIC RIGHT-OF-WAY
08	NOT AT INTERSECTION - IN BIKE PATH OR PARKING LANE
09	NOT-AT INTERSECTION - ON SIDEWALK
10	OUTSIDE TRAFFICWAY BOUNDARIES
13	AT INTERSECTION - IN BIKE LANE
14	NOT AT INTERSECTION - IN BIKE LANE
15	NOT AT INTERSECTION - INSIDE MID-BLOCK CROSSWALK
16	NOT AT INTERSECTION - IN PARKING LANE
18	OTHER, NOT IN ROADWAY
99	UNKNOWN LOCATION

**ROAD CHARACTER CODE TRANSLATION LIST**

CODE	SHORT DESC	LONG DESCRIPTION
0	UNK	UNKNOWN
1	INTER	INTERSECTION
2	ALLEY	DRIVEWAY OR ALLEY
3	STRGHT	STRAIGHT ROADWAY
4	TRANS	TRANSITION
5	CURVE	CURVE (HORIZONTAL CURVE)
6	OPENAC	OPEN ACCESS OR TURNOUT
7	GRADE	GRADE (VERTICAL CURVE)
8	BRIDGE	BRIDGE STRUCTURE
9	TUNNEL	TUNNEL

**PARTICIPANT TYPE CODE TRANSLATION LIST**

CODE	SHORT DESC	LONG DESCRIPTION
0	OCC	UNKNOWN OCCUPANT TYPE
1	DRVR	DRIVER
2	PSNG	PASSENGER
3	PED	PEDESTRIAN
4	CONV	PEDESTRIAN USING A PEDESTRIAN CONVEYAL
5	PTOW	PEDESTRIAN TOWING OR TRAILERING AN OB
6	BIKE	PEDALCYCLIST
7	BTOW	PEDALCYCLIST TOWING OR TRAILERING AN (
8	PRKD	OCCUPANT OF A PARKED MOTOR VEHICLE
9	UNK	UNKNOWN TYPE OF NON-MOTORIST

**TRAFFIC CONTROL DEVICE CODE TRANSLATION LIST**

CODE	SHORT DESC	LONG DESCRIPTION
000	NONE	NO CONTROL
001	TRF SIGNAL	TRAFFIC SIGNALS
002	FLASHBCN-R	FLASHING BEACON - RED (STOP)
003	FLASHBCN-A	FLASHING BEACON - AMBER (SLOW)
004	STOP SIGN	STOP SIGN
005	SLOW SIGN	SLOW SIGN
006	REG-SIGN	REGULATORY SIGN
007	YIELD	YIELD SIGN
008	WARNING	WARNING SIGN
009	CURVE	CURVE SIGN
010	SCHL X-ING	SCHOOL CROSSING SIGN OR SPECIAL SIGNAL
011	OFGR/FLAG	POLICE OFFICER, FLAGMAN - SCHOOL PATROL
012	BRDG-GATE	BRIDGE GATE - BARRIER
013	TEMP-BARR	TEMPORARY BARRIER
014	NO-PASS-ZN	NO PASSING ZONE
015	ONE-WAY	ONE-WAY STREET
016	CHANNEL	CHANNELIZATION
017	MEDIAN BAR	MEDIAN BARRIER
018	PILOT CAR	PILOT CAR
019	SP PED SIG	SPECIAL PEDESTRIAN SIGNAL
020	X-BUCK	CROSSBUCK
021	THR-GN-SIG	THROUGH GREEN ARROW OR SIGNAL
022	L-GRN-SIG	LEFT TURN GREEN ARROW, LANE MARKINGS, OR SIGNAL
023	R-GRN-SIG	RIGHT TURN GREEN ARROW, LANE MARKINGS, OR SIGNAL
024	WIGWAG	WIGWAG OR FLASHING LIGHTS W/O DROP-ARM GATE
025	X-BUCK WRN	CROSSBUCK AND ADVANCE WARNING
026	WW W/ GATE	FLASHING LIGHTS WITH DROP-ARM GATES
027	OVRHD SGNL	SUPPLEMENTAL OVERHEAD SIGNAL (RR XING ONLY)
028	SP RR STOP	SPECIAL RR STOP SIGN
029	ILUM GRD X	ILLUMINATED GRADE CROSSING
037	RAMP METER	METERED RAMPS
038	RUMBLE STR	RUMBLE STRIP
090	L-TURN REF	LEFT TURN REFUGE (WHEN REFUGE IS INVOLVED)
091	R-TURN ALL	RIGHT TURN AT ALL TIMES SIGN, ETC.
092	EMR SGN/FL	EMERGENCY SIGNS OR FLARES
093	ACCEL LANE	ACCELERATION OR DECELERATION LANES
094	R-TURN PRO	RIGHT TURN PROHIBITED ON RED AFTER STOPPING
095	BUS STPSGN	BUS STOP SIGN AND RED LIGHTS
099	UNKNOWN	UNKNOWN OR NOT DEFINITE



## VEHICLE TYPE CODE TRANSLATION LIST

CODE	SHORT DESC	LONG DESCRIPTION
00	PDO	NOT COLLECTED FOR PDO CRASHES
01	PSNGR CAR	PASSENGER CAR, PICKUP, LIGHT DELIVERY, ETC.
02	BOBTAIL	TRUCK TRACTOR WITH NO TRAILERS (BOBTAIL)
03	FARM TRCTR	FARM TRACTOR OR SELF-PROPELLED FARM EQUIPMENT
04	SEMI TOW	TRUCK TRACTOR WITH TRAILER/MOBILE HOME IN TOW
05	TRUCK	TRUCK WITH NON-DETACHABLE BED, PANEL, ETC.
06	MOPED	MOPED, MINIBIKE, SEATED MOTOR SCOOTER, MOTOR BIKE
07	SCHL BUS	SCHOOL BUS (INCLUDES VAN)
08	OTH BUS	OTHER BUS
09	MTRCYCLE	MOTORCYCLE, DIRT BIKE
10	OTHER	OTHER: FORKLIFT, BACKHOE, ETC.
11	MOTRHOME	MOTORHOME
12	TROLLEY	MOTORIZED STREET CAR/TROLLEY (NO RAILS/WIRES)
13	ATV	ATV
14	MTRSCTR	MOTORIZED SCOOTER (STANDING)
15	SNOWMOBILE	SNOWMOBILE
99	UNKNOWN	UNKNOWN VEHICLE TYPE

## WEATHER CONDITION CODE TRANSLATION LIST

CODE	SHORT DESC	LONG DESCRIPTION
0	UNK	UNKNOWN
1	CLR	CLEAR
2	CLD	CLOUDY
3	RAIN	RAIN
4	SLT	SLEET
5	FOG	FOG
6	SNOW	SNOW
7	DUST	DUST
8	SMOK	SMOKE
9	ASH	ASH

Appendix C  
Traffic Counts

**LOCATION:** SW Pacific Hwy -- SW Elwert Rd/SW Sunset Blvd  
**CITY/STATE:** Sherwood, OR

**QC JOB #:** 14401717  
**DATE:** Thu, May 11 2017

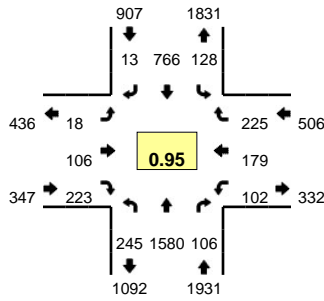

**Peak-Hour: 7:05 AM -- 8:05 AM**  
**Peak 15-Min: 7:40 AM -- 7:55 AM**

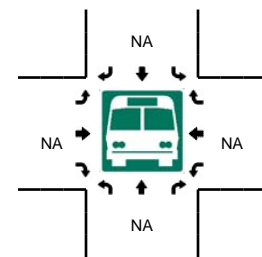
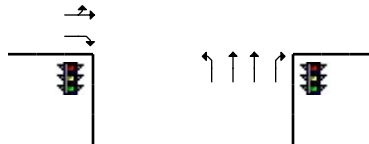
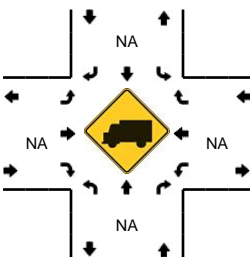
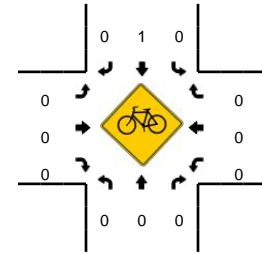
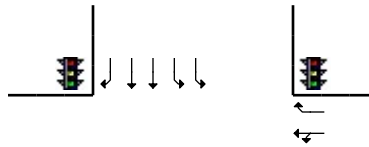
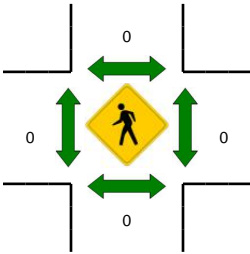
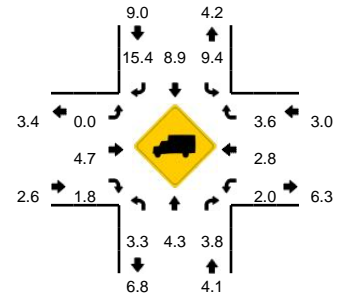

5-Min Count Period Beginning At	SW Pacific Hwy (Northbound)				SW Pacific Hwy (Southbound)				SW Elwert Rd/SW Sunset Blvd (Eastbound)				SW Elwert Rd/SW Sunset Blvd (Westbound)				Total	Hourly Totals
	Left	Thru	Right	U	Left	Thru	Right	U	Left	Thru	Right	U	Left	Thru	Right	U		
7:00 AM	22	126	6	0	2	43	0	1	0	5	15	0	11	13	12	0	256	
7:05 AM	10	136	9	0	3	71	2	0	3	5	19	0	8	8	17	0	291	
7:10 AM	20	118	8	0	8	54	1	1	1	7	25	0	14	19	12	0	288	
7:15 AM	34	127	9	0	6	44	1	1	1	9	17	0	9	15	19	0	292	
7:20 AM	23	140	8	0	5	60	0	0	3	5	16	0	16	8	16	0	300	
7:25 AM	22	154	14	0	7	76	1	0	0	5	14	0	3	15	16	0	327	
7:30 AM	19	119	7	0	11	50	1	1	4	14	20	0	4	21	17	0	288	
7:35 AM	22	123	5	0	12	52	1	1	1	9	14	0	13	25	16	0	294	
7:40 AM	20	139	9	0	13	64	0	1	1	9	14	0	7	19	19	0	315	
7:45 AM	23	122	7	0	20	69	2	2	2	9	21	0	7	15	23	0	322	
7:50 AM	14	121	8	0	11	100	2	0	0	13	24	0	8	14	23	0	338	
7:55 AM	26	115	10	0	17	59	1	1	2	10	20	0	7	11	29	0	308	3619
8:00 AM	11	166	12	1	7	67	1	0	0	11	19	0	6	9	18	0	328	3691
8:05 AM	8	79	9	0	8	63	0	1	1	5	26	0	10	5	15	0	230	3630
8:10 AM	16	81	4	0	6	48	0	3	2	2	11	0	7	14	12	0	206	3548
8:15 AM	12	133	6	0	6	83	0	1	1	4	12	0	5	7	12	0	282	3538
8:20 AM	23	98	8	0	6	40	0	4	0	6	16	0	7	8	7	0	223	3461
8:25 AM	11	110	9	0	6	55	0	2	2	2	19	0	7	8	9	0	240	3374
8:30 AM	16	76	5	0	13	51	0	3	0	3	10	0	7	6	14	0	204	3290
8:35 AM	17	128	7	0	7	66	2	1	1	8	13	0	5	9	11	0	275	3271
8:40 AM	9	112	11	0	9	62	1	1	1	3	10	0	3	4	3	0	229	3185
8:45 AM	8	93	8	0	7	60	0	0	1	4	10	0	11	8	17	0	227	3090
8:50 AM	9	96	11	0	3	59	0	1	1	7	23	0	7	6	12	0	235	2987
8:55 AM	9	86	6	0	8	74	1	3	1	8	8	0	5	3	11	0	223	2902
Peak 15-Min Flowrates	Northbound				Southbound				Eastbound				Westbound				Total	
	Left	Thru	Right	U	Left	Thru	Right	U	Left	Thru	Right	U	Left	Thru	Right	U		
All Vehicles	228	1528	96	0	176	932	16	12	12	124	236	0	88	192	260	0	3900	
Heavy Trucks	12	68	4		12	60	4		0	4	0		0	4	16		184	
Pedestrians	0	0	0		0	0	0		0	0	0		0	0	0		0	
Bicycles	0	0	0		0	0	0		0	0	0		0	0	0		0	
Railroad																		
Stopped Buses																		

Comments:

**LOCATION:** SW Woodhaven Dr -- SW Sunset Blvd  
**CITY/STATE:** Sherwood, OR

**QC JOB #:** 14538801  
**DATE:** Thu, Oct 12 2017

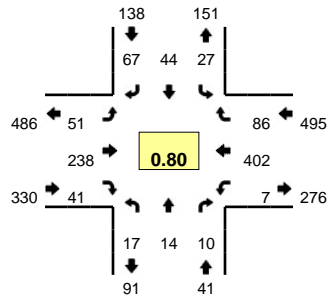

**Peak-Hour: 7:10 AM -- 8:10 AM**  
**Peak 15-Min: 7:45 AM -- 8:00 AM**

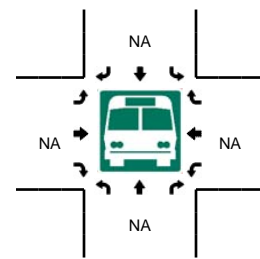
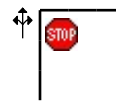
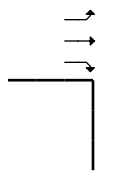
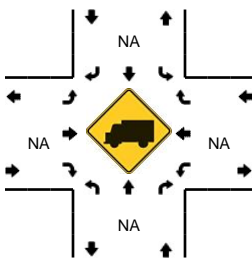
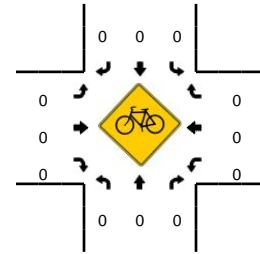
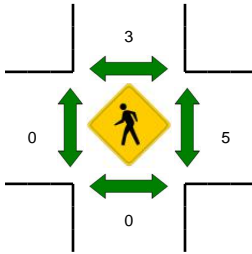
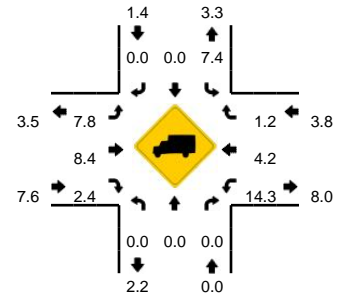

5-Min Count Period Beginning At	SW Woodhaven Dr (Northbound)				SW Woodhaven Dr (Southbound)				SW Sunset Blvd (Eastbound)				SW Sunset Blvd (Westbound)				Total	Hourly Totals
	Left	Thru	Right	U	Left	Thru	Right	U	Left	Thru	Right	U	Left	Thru	Right	U		
7:00 AM	0	0	1	0	0	1	4	0	4	7	1	0	0	32	3	0	53	
7:05 AM	6	1	1	0	0	0	3	0	2	17	0	0	0	27	2	0	59	
7:10 AM	1	0	0	0	4	0	7	0	1	13	1	0	0	32	0	1	60	
7:15 AM	0	0	0	0	1	0	6	0	0	19	2	0	0	31	2	0	61	
7:20 AM	0	0	0	0	0	0	3	0	3	15	3	0	0	36	5	0	65	
7:25 AM	2	1	0	0	2	4	9	0	1	20	0	0	1	29	7	0	76	
7:30 AM	1	1	1	0	2	6	5	0	3	14	3	0	0	38	9	0	83	
7:35 AM	4	0	1	0	3	6	5	0	2	25	10	0	0	32	11	0	99	
7:40 AM	1	1	0	0	2	11	5	0	2	27	10	0	2	31	5	0	97	
7:45 AM	2	2	0	0	1	13	10	0	5	26	7	0	1	39	9	0	115	
7:50 AM	1	3	2	0	7	2	3	0	7	21	1	0	1	31	12	0	91	
7:55 AM	3	3	4	0	1	0	7	0	11	26	3	0	1	36	13	0	108	967
8:00 AM	2	3	2	0	2	0	3	0	10	18	0	0	0	42	7	0	89	1003
8:05 AM	0	0	0	0	2	2	4	0	6	14	1	0	0	25	6	0	60	1004
8:10 AM	3	0	0	0	2	0	4	0	3	13	1	0	1	21	0	0	48	992
8:15 AM	1	1	0	0	1	0	2	0	3	16	1	0	0	17	1	0	43	974
8:20 AM	0	0	0	0	1	0	5	0	2	15	0	0	1	17	1	0	42	951
8:25 AM	1	0	0	0	0	1	2	0	7	10	0	0	0	24	1	0	46	921
8:30 AM	2	0	0	0	1	0	4	0	4	17	0	0	0	18	3	0	49	887
8:35 AM	1	1	0	0	0	0	3	0	7	11	0	0	0	21	3	0	47	835
8:40 AM	0	1	0	0	0	0	2	0	9	15	0	0	1	18	4	0	50	788
8:45 AM	2	0	1	0	0	1	5	0	2	7	0	0	0	27	6	0	51	724
8:50 AM	0	2	0	0	1	0	7	0	7	9	1	1	1	21	2	0	52	685
8:55 AM	1	0	0	0	3	0	4	0	11	9	0	0	0	13	3	0	44	621
Peak 15-Min Flowrates	Northbound				Southbound				Eastbound				Westbound				Total	
All Vehicles	24	32	24	0	36	60	80	0	92	292	44	0	12	424	136	0	1256	
Heavy Trucks	0	0	0	0	4	0	0	0	4	28	0	0	0	24	4	0	64	
Pedestrians	0	0	0	0	0	4	0	0	0	0	0	0	0	4	0	0	8	
Bicycles	0	0	0	0	0	0	0	0	0	0	0	0	0	0	0	0	0	
Railroad																		
Stopped Buses																		

Comments:

**LOCATION:** SW Timbrel Ln -- SW Sunset Blvd  
**CITY/STATE:** Sherwood, OR

**QC JOB #:** 14538803  
**DATE:** Thu, Oct 12 2017

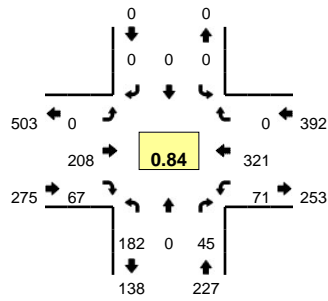

**Peak-Hour: 7:10 AM -- 8:10 AM**  
**Peak 15-Min: 7:40 AM -- 7:55 AM**

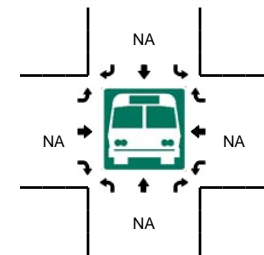
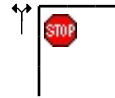
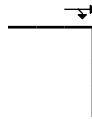
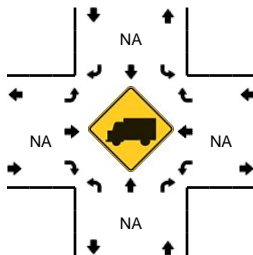
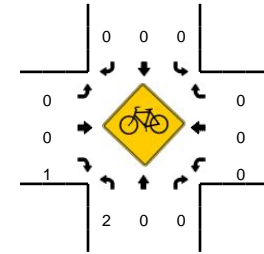
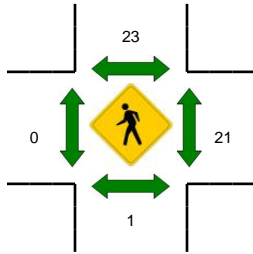
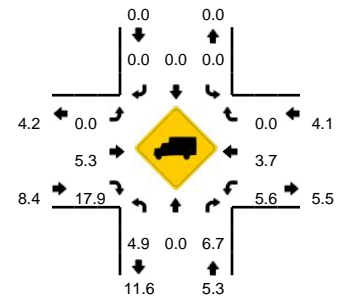

5-Min Count Period Beginning At	SW Timbrel Ln (Northbound)				SW Timbrel Ln (Southbound)				SW Sunset Blvd (Eastbound)				SW Sunset Blvd (Westbound)				Total	Hourly Totals	
	Left	Thru	Right	U	Left	Thru	Right	U	Left	Thru	Right	U	Left	Thru	Right	U			
7:00 AM	9	0	1	0	0	0	0	0	0	9	0	0	0	0	25	0	0	44	
7:05 AM	8	0	3	0	0	0	0	0	0	16	2	0	0	1	20	0	0	50	
7:10 AM	11	0	2	0	0	0	0	0	0	12	4	0	0	3	25	0	0	57	
7:15 AM	8	0	1	0	0	0	0	0	0	20	2	0	0	2	23	0	0	56	
7:20 AM	11	0	4	0	0	0	0	0	0	13	1	0	0	5	31	0	0	65	
7:25 AM	15	0	3	0	0	0	0	0	0	15	8	0	0	7	22	0	0	70	
7:30 AM	24	0	4	0	0	0	0	0	0	15	2	0	0	8	25	0	0	78	
7:35 AM	14	0	4	0	0	0	0	0	0	21	7	0	0	13	24	0	0	83	
7:40 AM	18	0	5	0	0	0	0	0	0	21	8	0	0	13	32	0	0	97	
7:45 AM	19	0	3	0	0	0	0	0	0	17	7	0	0	11	27	0	0	84	
7:50 AM	25	0	4	0	0	0	0	0	0	19	10	0	0	7	19	0	0	84	
7:55 AM	20	0	12	0	0	0	0	0	0	22	9	0	0	1	29	0	0	93	861
8:00 AM	8	0	3	0	0	0	0	0	0	18	5	0	0	1	40	0	0	75	892
8:05 AM	9	0	0	0	0	0	0	0	0	15	4	0	0	0	24	0	0	52	894
8:10 AM	7	0	3	0	0	0	0	0	0	11	3	0	0	2	11	0	0	37	874
8:15 AM	5	0	0	0	0	0	0	0	0	16	0	0	0	1	14	0	0	36	854
8:20 AM	4	0	0	0	0	0	0	0	0	13	2	0	0	1	14	0	0	34	823
8:25 AM	8	0	3	0	0	0	0	0	0	11	2	0	0	1	17	0	0	42	795
8:30 AM	6	0	1	0	0	0	0	0	0	17	1	0	0	1	16	0	0	42	759
8:35 AM	6	0	0	0	0	0	0	0	0	9	1	0	0	3	18	0	0	37	713
8:40 AM	4	0	2	0	0	0	0	0	0	13	0	0	0	3	20	0	0	42	658
8:45 AM	4	0	2	0	0	0	0	0	0	9	1	0	0	2	25	0	0	43	617
8:50 AM	8	0	0	0	0	0	0	0	0	7	3	0	0	1	17	0	0	36	569
8:55 AM	5	0	3	0	0	0	0	0	0	7	5	0	0	0	10	0	0	30	506
Peak 15-Min Flowrates	Northbound				Southbound				Eastbound				Westbound				Total		
	Left	Thru	Right	U	Left	Thru	Right	U	Left	Thru	Right	U	Left	Thru	Right	U			
All Vehicles	248	0	48	0	0	0	0	0	0	228	100	0	124	312	0	0	1060		
Heavy Trucks	16	0	8	0	0	0	0	0	0	8	20	0	8	16	0	0	76		
Pedestrians	0	0	0	0	64	0	0	0	0	0	0	0	0	64	0	0	128		
Bicycles	0	0	0	0	0	0	0	0	0	0	0	0	0	0	0	0	0		
Railroad																			
Stopped Buses																			

Comments:

**LOCATION:** SW Main St/SW Ladd Hill Rd -- SW Sunset Blvd  
**CITY/STATE:** Sherwood, OR

**QC JOB #:** 14487601  
**DATE:** Tue, Sep 12 2017

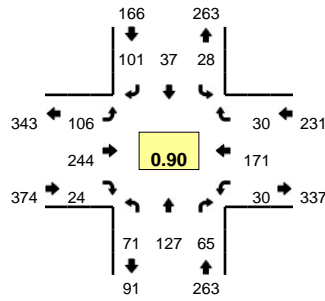

**Peak-Hour: 7:05 AM -- 8:05 AM**  
**Peak 15-Min: 7:30 AM -- 7:45 AM**

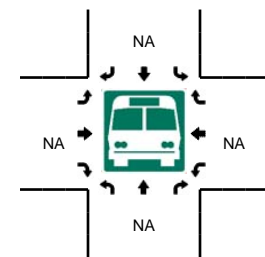
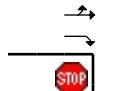
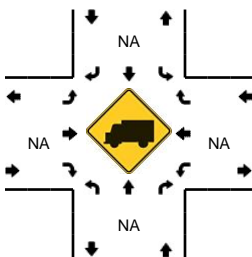
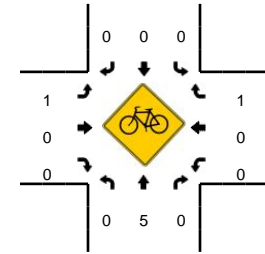
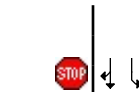
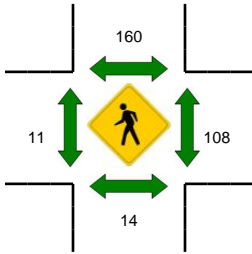
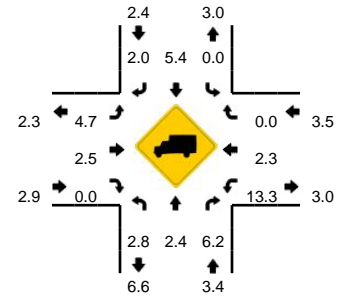

5-Min Count Period Beginning At	SW Main St/SW Ladd Hill Rd (Northbound)				SW Main St/SW Ladd Hill Rd (Southbound)				SW Sunset Blvd (Eastbound)				SW Sunset Blvd (Westbound)				Total	Hourly Totals
	Left	Thru	Right	U	Left	Thru	Right	U	Left	Thru	Right	U	Left	Thru	Right	U		
7:00 AM	3	8	2	0	0	2	2	0	7	16	1	0	1	8	2	0	52	
7:05 AM	4	6	7	0	0	2	2	0	4	19	1	0	1	12	2	0	60	
7:10 AM	4	11	3	0	1	3	5	0	5	19	1	0	1	14	4	0	71	
7:15 AM	1	12	6	0	1	3	8	0	6	21	1	0	1	11	3	0	74	
7:20 AM	8	12	6	0	0	1	10	0	9	17	4	0	2	24	2	0	95	
7:25 AM	9	11	6	0	0	2	7	0	9	23	1	0	2	17	4	0	91	
7:30 AM	5	13	8	0	4	1	11	0	11	22	2	0	5	14	2	0	98	
7:35 AM	8	10	4	0	4	2	13	0	13	21	0	0	1	13	4	0	93	
7:40 AM	17	11	1	0	3	2	14	0	12	14	1	0	6	14	2	0	97	
7:45 AM	8	12	2	0	5	5	9	0	15	15	1	0	2	15	0	0	89	
7:50 AM	3	14	8	0	2	2	8	0	14	23	4	0	1	12	4	0	95	
7:55 AM	1	8	8	0	3	9	7	0	3	23	3	0	4	11	0	0	80	995
8:00 AM	3	7	6	0	5	5	7	0	5	27	5	0	4	14	3	0	91	1034
8:05 AM	4	2	7	0	0	4	4	0	5	14	2	0	3	12	1	0	58	1032
8:10 AM	3	3	3	0	1	3	3	0	4	13	2	0	0	6	1	0	42	1003
8:15 AM	2	4	3	0	1	3	4	0	5	14	1	0	1	10	2	0	50	979
8:20 AM	2	6	1	0	1	2	3	0	5	14	5	0	2	9	1	0	51	935
8:25 AM	2	6	5	0	0	0	3	0	2	16	0	0	2	9	0	0	45	889
8:30 AM	2	1	4	0	0	2	2	0	1	8	0	0	2	6	1	0	29	820
8:35 AM	5	0	6	0	0	2	1	0	2	9	2	0	1	11	2	0	41	768
8:40 AM	3	4	5	0	0	1	3	0	2	11	0	0	3	8	2	0	42	713
8:45 AM	4	6	2	0	0	3	4	0	3	10	1	0	1	8	0	0	42	666
8:50 AM	5	5	2	0	1	3	3	0	4	10	3	0	3	12	3	0	54	625
8:55 AM	1	9	5	0	1	3	0	0	9	20	1	0	0	0	0	0	49	594
Peak 15-Min Flowrates	Northbound				Southbound				Eastbound				Westbound				Total	
All Vehicles	120	136	52	0	44	20	152	0	144	228	12	0	48	164	32	0	1152	
Heavy Trucks	8	8	4		0	0	4		12	8	0		4	8	0		56	
Pedestrians		24				360				4				236			624	
Bicycles	0	0	0		0	0	0		1	0	0		0	0	0		1	
Railroad																		
Stopped Buses																		

Comments:

**LOCATION:** SW Murdock Rd/SW Baker Rd -- SW Sunset Blvd/McKinley Dr  
**CITY/STATE:** Sherwood, OR

**QC JOB #:** 14548501  
**DATE:** Wed, Oct 25 2017

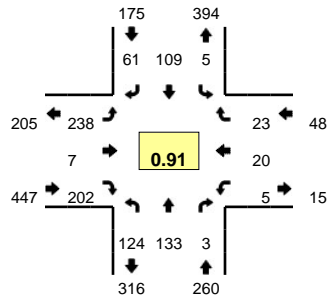

**Peak-Hour: 7:15 AM -- 8:15 AM**  
**Peak 15-Min: 7:35 AM -- 7:50 AM**

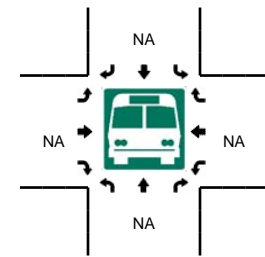
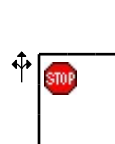
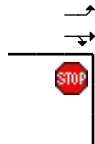
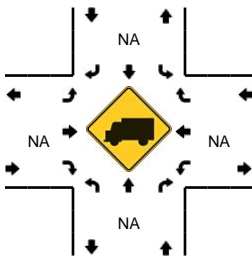
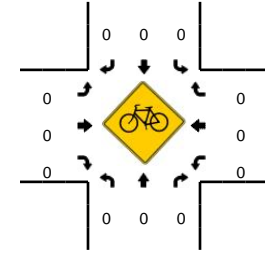
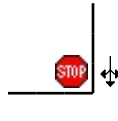
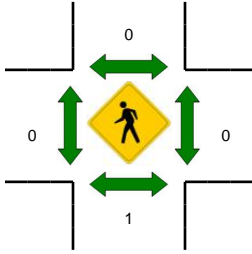
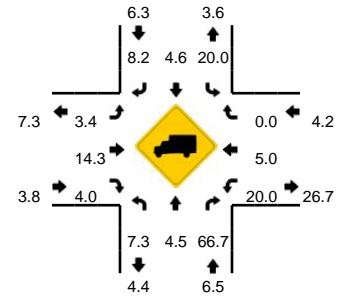

5-Min Count Period Beginning At	SW Murdock Rd/SW Baker Rd (Northbound)				SW Murdock Rd/SW Baker Rd (Southbound)				SW Sunset Blvd/McKinley Dr (Eastbound)				SW Sunset Blvd/McKinley Dr (Westbound)				Total	Hourly Totals
	Left	Thru	Right	U	Left	Thru	Right	U	Left	Thru	Right	U	Left	Thru	Right	U		
7:00 AM	14	5	0	0	0	8	6	0	22	0	8	0	0	0	1	0	64	
7:05 AM	10	9	0	0	0	5	3	0	18	0	9	0	0	0	4	0	58	
7:10 AM	11	6	0	0	1	6	3	0	17	0	11	0	0	0	2	0	57	
7:15 AM	12	8	0	0	0	6	5	0	15	1	16	0	0	1	3	0	67	
7:20 AM	20	10	1	0	0	6	6	0	22	0	20	0	0	2	1	0	88	
7:25 AM	8	12	2	0	0	5	5	0	17	0	18	0	1	4	4	0	76	
7:30 AM	12	7	0	0	1	9	2	0	23	1	16	0	2	0	1	0	74	
7:35 AM	11	14	0	0	0	11	7	0	24	1	22	0	0	6	2	0	98	
7:40 AM	13	8	0	0	0	12	1	0	20	0	17	0	1	2	1	0	75	
7:45 AM	13	14	0	0	0	13	7	0	17	0	13	0	0	3	3	0	83	
7:50 AM	10	19	0	0	0	10	8	0	19	1	10	0	1	0	5	0	83	
7:55 AM	5	12	0	0	2	7	7	0	17	0	18	0	0	0	2	0	70	893
8:00 AM	2	6	0	0	1	11	4	0	25	1	20	0	0	1	0	0	71	900
8:05 AM	11	11	0	0	0	7	7	0	24	1	20	0	0	1	0	0	82	924
8:10 AM	7	12	0	0	1	12	2	0	15	1	12	0	0	0	1	0	63	930
8:15 AM	8	11	0	0	0	8	3	0	11	2	14	0	0	1	3	0	61	924
8:20 AM	9	9	0	0	0	7	6	0	9	0	16	0	0	1	2	0	59	895
8:25 AM	5	7	0	0	0	5	9	0	13	1	7	0	0	1	1	0	49	868
8:30 AM	3	10	0	0	2	5	3	0	17	0	13	0	0	0	0	0	53	847
8:35 AM	1	5	0	0	1	4	4	0	12	0	9	0	0	0	1	0	37	786
8:40 AM	4	7	0	0	0	6	6	0	21	0	13	0	0	1	2	0	60	771
8:45 AM	8	8	0	0	1	10	3	0	13	0	8	0	0	2	2	0	55	743
8:50 AM	6	12	0	0	1	7	6	0	17	0	15	0	0	0	0	0	64	724
8:55 AM	6	6	0	0	0	5	3	0	12	1	8	0	0	1	0	0	42	696
Peak 15-Min Flowrates	Northbound				Southbound				Eastbound				Westbound				Total	
	Left	Thru	Right	U	Left	Thru	Right	U	Left	Thru	Right	U	Left	Thru	Right	U		
All Vehicles	148	144	0	0	0	144	60	0	244	4	208	0	4	44	24	0	1024	
Heavy Trucks	4	4	0	0	0	4	4	0	4	0	0	0	0	0	0	0	20	
Pedestrians		4				0				0				0			4	
Bicycles	0	0	0		0	0	0		0	0	0		0	0	0		0	
Railroad																		
Stopped Buses																		

Comments:

**LOCATION:** SW Pacific Hwy -- SW Chapman Rd  
**CITY/STATE:** Sherwood, OR

**QC JOB #:** 14401706  
**DATE:** Thu, May 11 2017

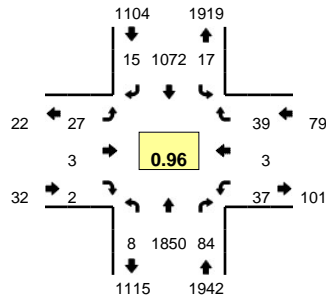

**Peak-Hour: 7:05 AM -- 8:05 AM**  
**Peak 15-Min: 7:30 AM -- 7:45 AM**

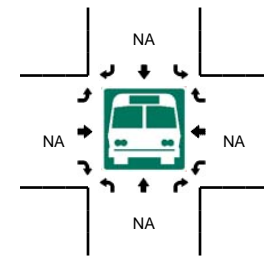
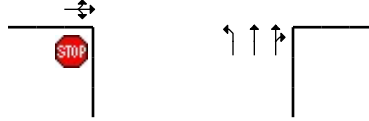
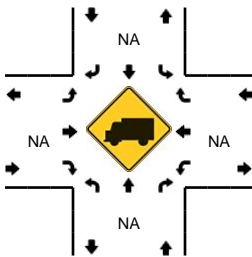
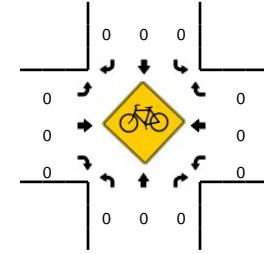
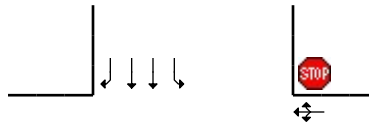
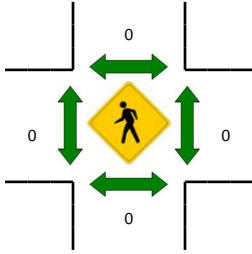
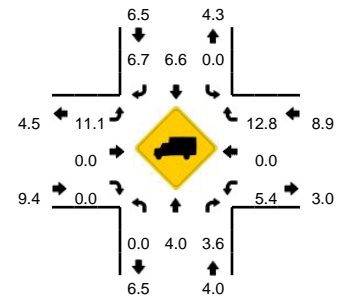

5-Min Count Period Beginning At	SW Pacific Hwy (Northbound)				SW Pacific Hwy (Southbound)				SW Chapman Rd (Eastbound)				SW Chapman Rd (Westbound)				Total	Hourly Totals
	Left	Thru	Right	U	Left	Thru	Right	U	Left	Thru	Right	U	Left	Thru	Right	U		
7:00 AM	0	133	2	0	0	74	0	0	1	0	0	0	4	0	3	0	217	
7:05 AM	0	169	5	1	0	81	4	0	0	0	0	0	2	0	0	0	262	
7:10 AM	0	159	6	0	0	99	1	1	1	0	0	0	1	0	1	0	269	
7:15 AM	1	165	11	0	1	75	0	0	0	1	0	0	2	0	2	0	258	
7:20 AM	0	174	7	0	0	100	0	1	1	1	0	0	3	0	1	0	288	
7:25 AM	0	141	8	1	1	78	1	0	3	0	0	0	4	0	2	0	239	
7:30 AM	0	177	8	0	1	84	0	0	4	0	1	0	0	1	4	0	280	
7:35 AM	0	177	8	0	0	85	1	0	0	0	0	0	4	0	3	0	278	
7:40 AM	1	147	14	1	1	85	1	0	4	0	0	0	3	1	5	0	263	
7:45 AM	1	142	9	0	4	99	2	0	3	0	0	0	2	0	4	0	266	
7:50 AM	0	147	6	0	1	125	1	1	2	0	0	0	4	1	3	0	291	
7:55 AM	1	133	1	0	3	82	2	0	1	1	1	0	8	0	6	0	239	3150
8:00 AM	0	119	1	1	2	79	2	0	8	0	0	0	4	0	8	0	224	3157
8:05 AM	0	98	4	0	2	85	4	0	5	0	0	0	2	1	1	0	202	3097
8:10 AM	0	127	2	0	1	82	1	0	0	1	0	0	3	0	1	0	218	3046
8:15 AM	0	130	3	0	2	72	2	0	3	0	1	0	2	0	2	0	217	3005
8:20 AM	1	135	6	0	1	89	1	1	0	1	0	0	3	0	2	0	240	2957
8:25 AM	0	115	5	0	3	63	0	0	0	0	0	0	0	0	1	0	187	2905
8:30 AM	0	127	3	0	1	71	0	0	1	0	0	0	3	1	3	0	210	2835
8:35 AM	0	118	3	0	1	83	2	0	2	0	0	0	0	1	1	0	211	2768
8:40 AM	1	143	0	1	1	68	2	1	1	0	0	0	3	0	0	0	221	2726
8:45 AM	0	108	1	0	1	87	4	1	0	1	0	0	3	0	2	0	208	2668
8:50 AM	1	127	3	0	0	88	1	0	0	1	1	0	1	0	1	0	224	2601
8:55 AM	0	93	4	0	1	89	3	0	2	1	1	0	3	1	1	0	199	2561
Peak 15-Min Flowrates	Northbound				Southbound				Eastbound				Westbound				Total	
	Left	Thru	Right	U	Left	Thru	Right	U	Left	Thru	Right	U	Left	Thru	Right	U		
All Vehicles	4	2004	120	4	8	1016	8	0	32	0	4	0	28	8	48	0	3284	
Heavy Trucks	0	64	4		0	100	0		0	0	0		4	0	4		176	
Pedestrians	0				0				0				0				0	
Bicycles	0				0				0				0				0	
Railroad																		
Stopped Buses																		

Comments:



**LOCATION:** SW Old Hwy 99W -- SW Brookman Rd  
**CITY/STATE:** Sherwood, OR

**QC JOB #:** 14401709  
**DATE:** Thu, May 11 2017

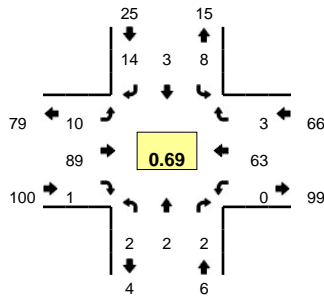

**Peak-Hour: 7:10 AM -- 8:10 AM**  
**Peak 15-Min: 7:40 AM -- 7:55 AM**

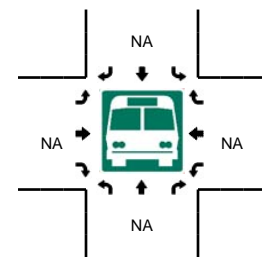
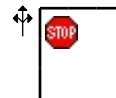
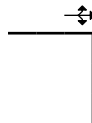
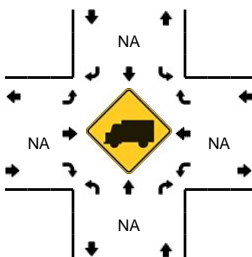
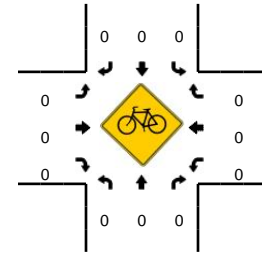
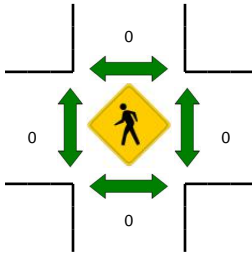
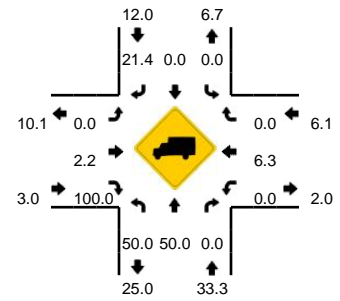

5-Min Count Period Beginning At	SW Old Hwy 99W (Northbound)				SW Old Hwy 99W (Southbound)				SW Brookman Rd (Eastbound)				SW Brookman Rd (Westbound)				Total	Hourly Totals		
	Left	Thru	Right	U	Left	Thru	Right	U	Left	Thru	Right	U	Left	Thru	Right	U				
7:00 AM	0	1	0	0	0	0	0	0	0	1	1	0	0	0	4	0	0	7		
7:05 AM	0	0	0	0	0	0	1	0	0	2	0	0	0	1	0	0	0	4		
7:10 AM	0	0	0	0	0	0	0	0	1	6	0	0	0	1	1	0	0	8		
7:15 AM	1	1	0	0	0	0	1	0	2	11	0	0	0	2	0	0	0	18		
7:20 AM	0	0	1	0	0	0	0	0	1	5	0	0	0	6	0	0	0	13		
7:25 AM	0	0	0	0	0	0	0	0	0	11	0	0	0	5	0	0	0	16		
7:30 AM	0	0	0	0	0	0	0	0	0	9	0	0	0	3	0	0	0	12		
7:35 AM	0	0	0	0	1	0	1	0	1	7	0	0	0	8	0	0	0	18		
7:40 AM	0	0	0	0	2	1	2	0	1	11	1	0	0	4	2	0	0	24		
7:45 AM	1	0	0	0	2	0	3	0	2	11	0	0	0	3	0	0	0	22		
7:50 AM	0	0	1	0	2	0	5	0	0	7	0	0	0	10	0	0	0	25		
7:55 AM	0	0	0	0	0	1	0	0	2	4	0	0	0	10	1	0	0	18	185	
8:00 AM	0	1	0	0	0	0	1	0	0	1	0	0	0	8	0	0	0	11	189	
8:05 AM	0	0	0	0	1	1	1	0	0	6	0	0	0	3	0	0	0	12	197	
8:10 AM	0	0	0	0	0	0	1	0	0	5	0	0	0	2	0	0	0	8	197	
8:15 AM	0	0	0	0	0	0	2	0	0	4	0	0	0	2	0	0	0	8	187	
8:20 AM	0	0	0	0	0	0	0	0	0	7	0	0	0	5	0	0	0	12	186	
8:25 AM	0	2	0	0	0	0	0	0	0	6	0	0	0	0	0	0	0	8	178	
8:30 AM	0	0	0	0	0	0	1	0	1	3	0	0	0	4	0	0	0	9	175	
8:35 AM	0	0	0	0	0	0	0	0	1	3	0	0	0	2	0	0	0	6	163	
8:40 AM	0	2	0	0	0	1	0	0	0	0	0	0	0	3	0	0	0	6	145	
8:45 AM	0	0	0	0	0	0	0	0	0	3	0	0	0	5	0	0	0	8	131	
8:50 AM	0	0	0	0	0	1	1	0	0	2	0	0	0	4	0	0	0	8	114	
8:55 AM	0	0	0	0	0	0	1	0	0	6	0	0	0	2	0	0	0	9	105	
Peak 15-Min Flowrates	Northbound				Southbound				Eastbound				Westbound				Total			
	Left	Thru	Right	U	Left	Thru	Right	U	Left	Thru	Right	U	Left	Thru	Right	U				
All Vehicles	4	0	4	0	24	4	40	0	12	116	4	0	0	68	8	0	0	284		
Heavy Trucks	4	0	0	0	0	0	12	0	0	0	4	0	0	4	0	0	0	24		
Pedestrians	0	0	0	0	0	0	0	0	0	0	0	0	0	0	0	0	0	0		
Bicycles	0	0	0	0	0	0	0	0	0	0	0	0	0	0	0	0	0	0		
Railroad																				
Stopped Buses																				

Comments:

**LOCATION:** SW Middleton Rd -- SW Brookman Rd  
**CITY/STATE:** Sherwood, OR

**QC JOB #:** 14401711  
**DATE:** Thu, May 11 2017

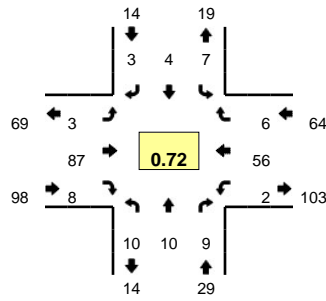

**Peak-Hour: 7:15 AM -- 8:15 AM**  
**Peak 15-Min: 7:40 AM -- 7:55 AM**

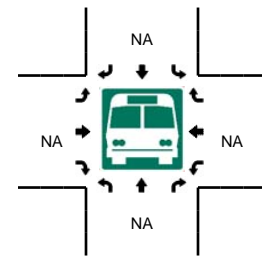
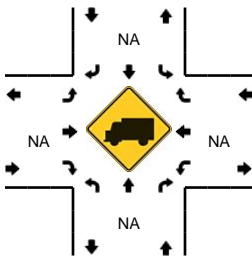
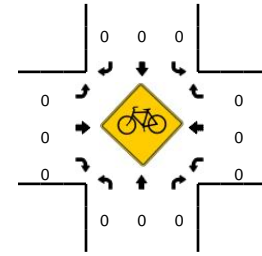
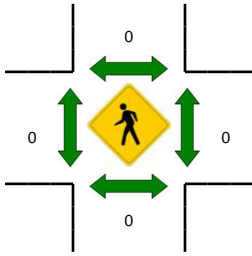
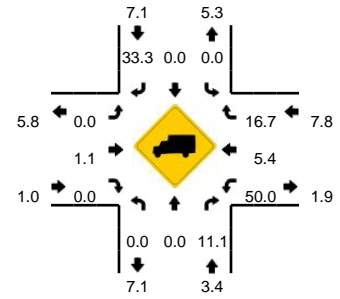

5-Min Count Period Beginning At	SW Middleton Rd (Northbound)				SW Middleton Rd (Southbound)				SW Brookman Rd (Eastbound)				SW Brookman Rd (Westbound)				Total	Hourly Totals
	Left	Thru	Right	U	Left	Thru	Right	U	Left	Thru	Right	U	Left	Thru	Right	U		
7:00 AM	1	1	0	0	0	0	1	0	0	0	0	0	0	0	0	0	3	
7:05 AM	0	0	0	0	1	0	0	0	0	2	1	0	0	1	0	0	5	
7:10 AM	0	1	0	0	0	0	0	0	0	5	0	0	0	1	0	0	7	
7:15 AM	0	0	0	0	1	0	0	0	1	10	0	0	0	4	0	0	16	
7:20 AM	1	2	1	0	0	0	0	0	0	8	0	0	1	3	0	0	16	
7:25 AM	1	0	0	0	0	0	0	0	0	9	1	0	0	5	0	0	16	
7:30 AM	1	2	1	0	2	1	0	0	0	9	0	0	0	4	0	0	20	
7:35 AM	0	0	1	0	0	0	0	0	1	8	0	0	0	8	0	0	18	
7:40 AM	1	5	1	0	2	0	1	0	0	10	0	0	0	4	2	0	26	
7:45 AM	0	0	2	0	1	1	0	0	1	12	2	0	1	5	1	0	26	
7:50 AM	2	0	0	0	1	0	0	0	0	10	1	0	0	5	0	0	19	
7:55 AM	0	0	1	0	0	2	1	0	0	3	1	0	0	8	1	0	17	189
8:00 AM	3	1	1	0	0	0	1	0	0	0	2	0	0	5	1	0	14	200
8:05 AM	1	0	0	0	0	0	0	0	0	5	1	0	0	2	0	0	9	204
8:10 AM	0	0	1	0	0	0	0	0	0	3	0	0	0	3	1	0	8	205
8:15 AM	1	0	0	0	0	0	0	0	0	5	1	0	0	1	0	0	8	197
8:20 AM	3	0	0	0	0	0	0	0	0	4	0	0	1	1	0	0	9	190
8:25 AM	0	0	1	0	0	0	0	0	2	6	1	0	0	0	0	0	10	184
8:30 AM	1	0	0	0	0	0	0	0	0	2	1	0	0	3	0	0	7	171
8:35 AM	0	0	0	0	1	0	0	0	0	3	0	0	0	2	0	0	6	159
8:40 AM	2	1	0	0	1	0	0	0	0	0	0	0	0	4	0	0	8	141
8:45 AM	1	0	0	0	0	0	0	0	0	2	0	0	1	2	1	0	7	122
8:50 AM	0	0	0	0	0	0	0	0	0	2	1	0	0	3	0	0	6	109
8:55 AM	0	0	0	0	0	0	1	0	0	6	0	0	0	1	0	0	8	100
Peak 15-Min Flowrates	Northbound				Southbound				Eastbound				Westbound				Total	
	Left	Thru	Right	U	Left	Thru	Right	U	Left	Thru	Right	U	Left	Thru	Right	U		
All Vehicles	12	20	12	0	16	4	4	0	4	128	12	0	4	56	12	0	284	
Heavy Trucks	0	0	0		0	0	0		0	0	0		0	4	4		8	
Pedestrians		0				0				0				0			0	
Bicycles	0	0	0		0	0	0		0	0	0		0	0	0		0	
Railroad																		
Stopped Buses																		

Comments:

**LOCATION:** SW Oberst Rd -- SW Brookman Rd  
**CITY/STATE:** Sherwood, OR

**QC JOB #:** 14401713  
**DATE:** Thu, May 11 2017

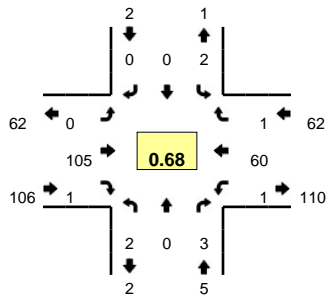

**Peak-Hour: 7:10 AM -- 8:10 AM**  
**Peak 15-Min: 7:40 AM -- 7:55 AM**

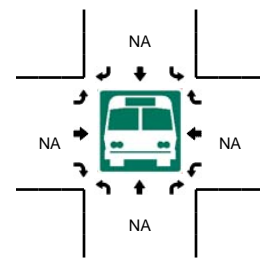
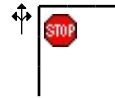
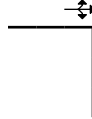
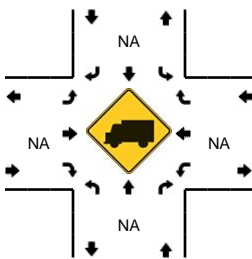
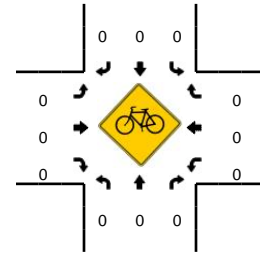
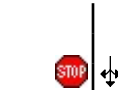
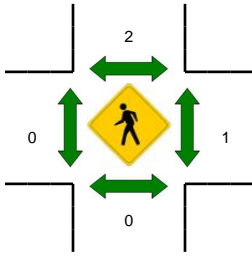
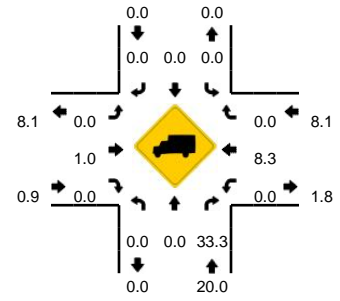

5-Min Count Period Beginning At	SW Oberst Rd (Northbound)				SW Oberst Rd (Southbound)				SW Brookman Rd (Eastbound)				SW Brookman Rd (Westbound)				Total	Hourly Totals
	Left	Thru	Right	U	Left	Thru	Right	U	Left	Thru	Right	U	Left	Thru	Right	U		
7:00 AM	0	0	0	0	0	0	0	0	0	2	0	0	0	0	0	0	2	
7:05 AM	0	0	1	0	0	0	0	0	0	3	0	0	0	0	1	0	5	
7:10 AM	0	0	0	0	0	0	0	0	0	6	0	0	0	0	1	1	8	
7:15 AM	0	0	0	0	1	0	0	0	0	9	0	0	0	0	5	0	15	
7:20 AM	0	0	0	0	0	0	0	0	0	9	0	0	0	0	3	0	12	
7:25 AM	0	0	1	0	0	0	0	0	0	11	1	0	0	0	5	0	18	
7:30 AM	0	0	1	0	0	0	0	0	0	10	0	0	0	1	5	0	17	
7:35 AM	1	0	1	0	0	0	0	0	0	8	0	0	0	0	5	0	15	
7:40 AM	0	0	0	0	0	0	0	0	0	16	0	0	0	0	7	0	23	
7:45 AM	0	0	0	0	0	0	0	0	0	16	0	0	0	0	7	0	23	
7:50 AM	1	0	0	0	0	0	0	0	0	10	0	0	0	0	7	0	18	
7:55 AM	0	0	0	0	0	0	0	0	0	4	0	0	0	0	6	0	10	166
8:00 AM	0	0	0	0	0	0	0	0	0	2	0	0	0	0	6	0	8	172
8:05 AM	0	0	0	0	1	0	0	0	0	4	0	0	0	0	3	0	8	175
8:10 AM	1	0	0	0	0	0	0	0	0	4	0	0	0	0	2	0	7	174
8:15 AM	0	0	0	0	0	0	0	0	0	5	0	0	0	0	1	0	6	165
8:20 AM	0	0	1	0	0	0	0	0	0	2	0	0	0	0	2	0	5	158
8:25 AM	0	0	0	0	0	0	0	0	0	7	0	0	0	0	1	0	8	148
8:30 AM	0	0	0	0	0	0	0	0	0	4	0	0	0	0	2	0	6	137
8:35 AM	0	0	0	0	0	0	0	0	0	5	0	0	0	0	1	0	6	128
8:40 AM	0	0	0	0	0	0	0	0	0	1	0	0	0	0	5	0	6	111
8:45 AM	0	0	0	0	0	0	0	0	0	1	0	0	0	1	3	0	5	93
8:50 AM	0	0	0	0	1	0	0	0	0	3	0	0	0	0	2	0	6	81
8:55 AM	0	0	0	0	0	0	0	0	0	5	0	0	0	0	0	0	5	76
Peak 15-Min Flowrates	Northbound				Southbound				Eastbound				Westbound				Total	
	Left	Thru	Right	U	Left	Thru	Right	U	Left	Thru	Right	U	Left	Thru	Right	U		
All Vehicles	4	0	0	0	0	0	0	0	0	168	0	0	0	84	0	0	256	
Heavy Trucks	0	0	0	0	0	0	0	0	0	0	0	0	0	8	0	0	8	
Pedestrians	0	0	0	0	0	0	0	0	0	0	0	0	0	0	0	0	0	
Bicycles	0	0	0	0	0	0	0	0	0	0	0	0	0	0	0	0	0	
Railroad																		
Stopped Buses																		

Comments:

**LOCATION:** SW Ladd Hill Rd -- SW Brookman Rd  
**CITY/STATE:** Sherwood, OR

**QC JOB #:** 14401715  
**DATE:** Thu, May 11 2017

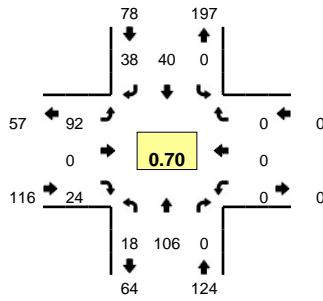

**Peak-Hour: 7:10 AM -- 8:10 AM**  
**Peak 15-Min: 7:40 AM -- 7:55 AM**

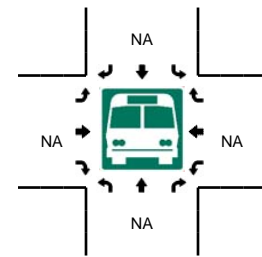
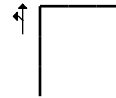
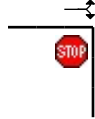
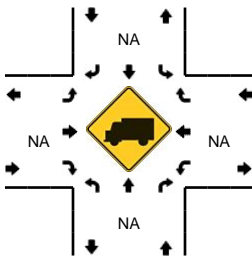
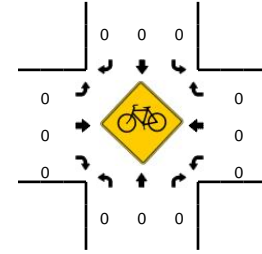
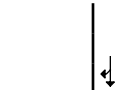
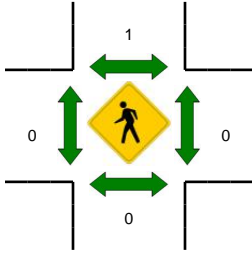
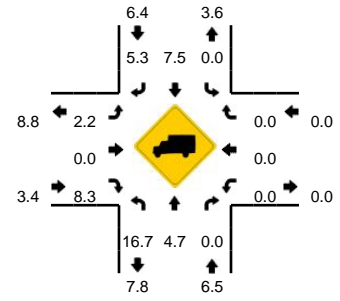

5-Min Count Period Beginning At	SW Ladd Hill Rd (Northbound)				SW Ladd Hill Rd (Southbound)				SW Brookman Rd (Eastbound)				SW Brookman Rd (Westbound)				Total	Hourly Totals
	Left	Thru	Right	U	Left	Thru	Right	U	Left	Thru	Right	U	Left	Thru	Right	U		
7:00 AM	0	2	0	0	0	0	0	0	2	0	1	0	0	0	0	0	5	
7:05 AM	0	5	0	0	0	0	0	0	1	0	0	0	0	0	0	0	6	
7:10 AM	1	7	0	0	0	3	2	0	7	0	2	0	0	0	0	0	22	
7:15 AM	0	5	0	0	0	3	3	0	5	0	3	0	0	0	0	0	19	
7:20 AM	2	8	0	0	0	1	1	0	4	0	3	0	0	0	0	0	19	
7:25 AM	1	4	0	0	0	2	4	0	4	0	1	0	0	0	0	0	16	
7:30 AM	3	12	0	0	0	5	2	0	13	0	3	0	0	0	0	0	38	
7:35 AM	3	8	0	0	0	0	2	0	10	0	2	0	0	0	0	0	25	
7:40 AM	0	17	0	0	0	5	5	0	10	0	3	1	0	0	0	0	41	
7:45 AM	2	12	0	0	0	2	5	0	13	0	2	0	0	0	0	0	36	
7:50 AM	5	9	0	0	0	4	4	0	13	0	1	0	0	0	0	0	36	
7:55 AM	1	11	0	0	0	6	3	0	5	0	4	0	0	0	0	0	30	293
8:00 AM	0	5	0	0	0	6	2	0	2	0	0	0	0	0	0	0	15	303
8:05 AM	0	8	0	0	0	3	5	0	5	0	0	0	0	0	0	0	21	318
8:10 AM	0	7	0	0	0	5	0	0	4	0	1	0	0	0	0	0	17	313
8:15 AM	0	7	0	0	0	1	1	0	3	0	1	0	0	0	0	0	13	307
8:20 AM	1	3	0	0	0	3	0	0	2	0	2	0	0	0	0	0	11	299
8:25 AM	0	5	0	0	0	3	3	0	6	0	1	0	0	0	0	0	18	301
8:30 AM	0	2	0	0	0	4	0	0	4	0	0	0	0	0	0	0	10	273
8:35 AM	0	5	0	0	0	6	3	0	1	0	0	0	0	0	0	0	15	263
8:40 AM	2	3	0	0	0	5	2	0	3	0	2	0	0	0	0	0	17	239
8:45 AM	0	4	0	0	0	5	3	0	0	0	1	0	0	0	0	0	13	216
8:50 AM	1	4	0	0	0	4	1	0	1	0	1	0	0	0	0	0	12	192
8:55 AM	1	7	0	0	0	6	0	0	5	0	0	0	0	0	0	0	19	181
Peak 15-Min Flowrates	Northbound				Southbound				Eastbound				Westbound				Total	
	Left	Thru	Right	U	Left	Thru	Right	U	Left	Thru	Right	U	Left	Thru	Right	U		
All Vehicles	28	152	0	0	0	44	56	0	144	0	24	4	0	0	0	0	452	
Heavy Trucks	0	0	0	0	0	0	8	0	0	0	4	0	0	0	0	0	12	
Pedestrians	0	0	0	0	0	0	0	0	0	0	0	0	0	0	0	0	0	
Bicycles	0	0	0	0	0	0	0	0	0	0	0	0	0	0	0	0	0	
Railroad																		
Stopped Buses																		

Comments:

**LOCATION:** SW Pacific Hwy -- SW Elwert Rd/SW Sunset Blvd  
**CITY/STATE:** Sherwood, OR

**QC JOB #:** 14401718  
**DATE:** Thu, May 11 2017

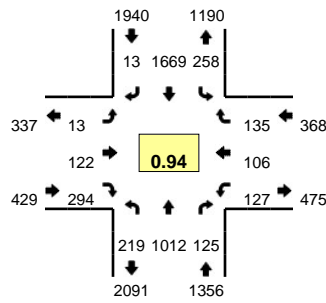

**Peak-Hour: 4:40 PM -- 5:40 PM**  
**Peak 15-Min: 5:10 PM -- 5:25 PM**

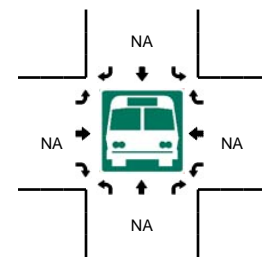
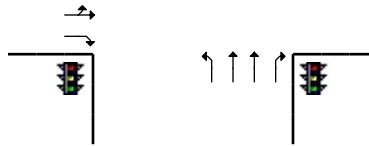
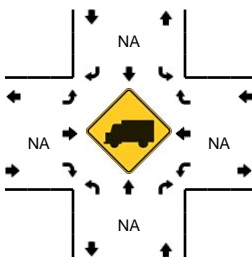
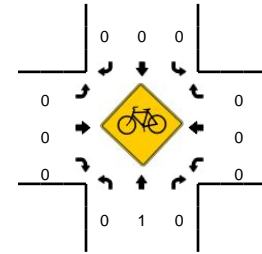
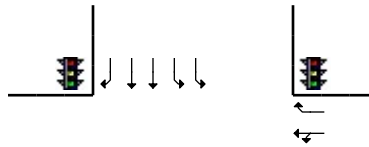
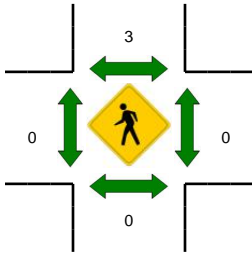
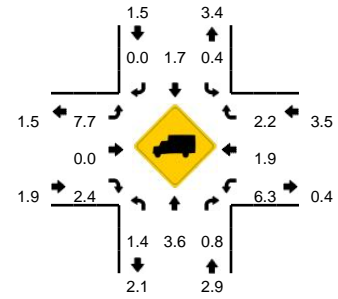

5-Min Count Period Beginning At	SW Pacific Hwy (Northbound)				SW Pacific Hwy (Southbound)				SW Elwert Rd/SW Sunset Blvd (Eastbound)				SW Elwert Rd/SW Sunset Blvd (Westbound)				Total	Hourly Totals
	Left	Thru	Right	U	Left	Thru	Right	U	Left	Thru	Right	U	Left	Thru	Right	U		
4:00 PM	15	71	6	1	11	141	3	4	3	11	27	0	10	6	6	0	315	
4:05 PM	4	62	14	0	14	154	0	1	0	12	26	0	7	5	11	0	310	
4:10 PM	12	76	3	0	11	132	0	2	0	10	27	0	9	8	10	0	300	
4:15 PM	13	96	13	1	10	111	3	3	1	7	25	0	11	8	15	0	317	
4:20 PM	16	91	13	1	13	149	0	5	0	12	18	0	13	7	11	0	349	
4:25 PM	13	82	5	0	12	140	2	3	1	9	21	0	12	10	16	0	326	
4:30 PM	22	73	10	0	12	110	3	2	0	11	28	0	6	7	11	0	295	
4:35 PM	16	82	8	0	19	121	2	6	0	11	26	0	10	8	11	0	320	
4:40 PM	24	100	17	1	13	129	1	2	0	7	29	0	12	8	9	0	352	
4:45 PM	23	79	9	0	19	136	0	3	1	7	22	0	11	19	15	0	344	
4:50 PM	22	87	11	0	22	124	1	3	2	12	27	0	11	10	12	0	344	
4:55 PM	14	78	16	0	25	136	1	1	2	6	28	0	12	8	18	0	345	3917
5:00 PM	19	77	8	0	10	117	0	5	2	11	29	0	9	11	10	0	308	3910
5:05 PM	13	63	8	0	16	153	2	2	0	12	22	0	17	6	16	0	330	3930
5:10 PM	16	80	9	0	22	158	0	0	1	13	23	0	13	4	10	0	349	3979
5:15 PM	15	95	17	0	14	157	2	2	5	7	22	0	11	10	8	0	365	4027
5:20 PM	14	108	4	0	25	154	1	4	0	12	22	0	12	9	12	0	377	4055
5:25 PM	22	75	7	0	16	142	1	5	0	13	24	0	6	8	7	0	326	4055
5:30 PM	21	93	11	0	25	110	2	1	0	9	27	0	7	6	11	0	323	4083
5:35 PM	15	77	8	0	21	153	2	2	0	13	19	0	6	7	7	0	330	4093
5:40 PM	17	89	9	0	21	131	0	7	0	10	25	0	4	8	8	0	329	4070
5:45 PM	17	88	13	0	8	136	3	1	1	5	26	0	7	8	11	0	324	4050
5:50 PM	19	87	15	0	22	134	0	3	1	11	25	0	10	5	11	0	343	4049
5:55 PM	17	64	8	0	31	134	4	2	0	12	15	0	11	6	11	0	315	4019
Peak 15-Min Flowrates	Northbound				Southbound				Eastbound				Westbound				Total	
	Left	Thru	Right	U	Left	Thru	Right	U	Left	Thru	Right	U	Left	Thru	Right	U		
All Vehicles	180	1132	120	0	244	1876	12	24	24	128	268	0	144	92	120	0	4364	
Heavy Trucks	8	40	4		0	20	0		4	0	8		8	0	0		92	
Pedestrians		0				8				0				0			8	
Bicycles	0	0	0		0	0	0		0	0	0		0	0	0		0	
Railroad																		
Stopped Buses																		

Comments:

**LOCATION:** SW Woodhaven Dr -- SW Sunset Blvd  
**CITY/STATE:** Sherwood, OR

**QC JOB #:** 14538802  
**DATE:** Thu, Oct 12 2017

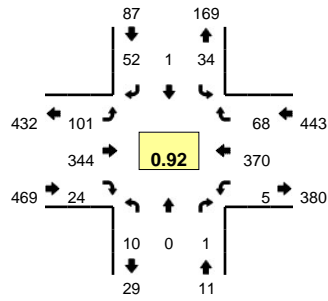

**Peak-Hour: 4:45 PM -- 5:45 PM**  
**Peak 15-Min: 5:15 PM -- 5:30 PM**

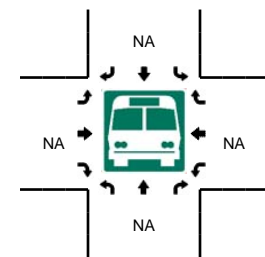
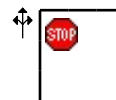
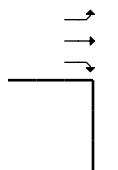
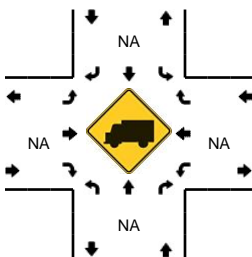
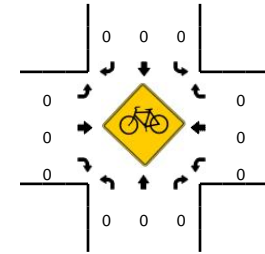
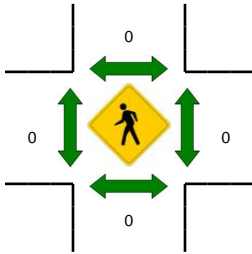
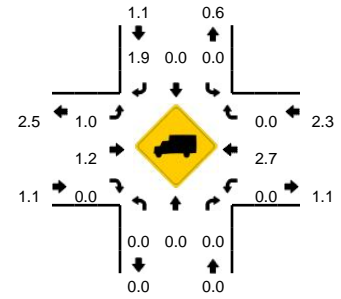

5-Min Count Period Beginning At	SW Woodhaven Dr (Northbound)				SW Woodhaven Dr (Southbound)				SW Sunset Blvd (Eastbound)				SW Sunset Blvd (Westbound)				Total	Hourly Totals
	Left	Thru	Right	U	Left	Thru	Right	U	Left	Thru	Right	U	Left	Thru	Right	U		
4:00 PM	0	0	0	0	2	0	3	0	8	20	1	0	0	20	2	0	56	
4:05 PM	0	2	1	0	4	0	3	0	7	19	1	0	0	21	3	0	61	
4:10 PM	0	0	0	0	1	0	6	0	3	19	1	0	0	19	3	0	52	
4:15 PM	0	0	0	0	3	0	2	0	6	20	1	0	2	33	5	0	72	
4:20 PM	0	0	0	0	2	0	2	0	3	18	1	0	0	25	3	0	54	
4:25 PM	1	0	0	0	4	0	3	0	7	15	0	0	0	22	6	0	58	
4:30 PM	0	0	0	0	3	0	3	0	6	20	2	0	0	26	0	0	60	
4:35 PM	0	0	1	0	2	0	2	0	9	30	0	0	1	22	1	0	68	
4:40 PM	1	0	0	0	4	0	5	0	5	24	2	1	1	27	3	0	73	
4:45 PM	1	0	0	0	5	0	2	0	8	24	3	0	1	31	5	0	80	
4:50 PM	3	0	0	0	3	0	6	0	10	21	1	0	0	28	4	1	77	
4:55 PM	1	0	1	0	1	0	1	0	5	28	1	0	1	28	10	0	77	788
5:00 PM	1	0	0	0	1	0	6	0	11	35	2	0	1	26	4	0	87	819
5:05 PM	0	0	0	0	2	0	5	0	10	34	3	0	1	30	5	0	90	848
5:10 PM	0	0	0	0	4	0	5	0	3	21	1	0	0	29	7	0	70	866
5:15 PM	1	0	0	0	2	0	4	0	8	26	4	0	0	42	3	0	90	884
5:20 PM	0	0	0	0	2	0	2	0	9	40	1	0	0	35	9	0	98	928
5:25 PM	1	0	0	0	7	1	9	0	8	25	3	0	0	27	4	0	85	955
5:30 PM	2	0	0	0	1	0	2	0	10	31	2	0	0	30	6	0	84	979
5:35 PM	0	0	0	0	4	0	4	0	8	28	2	0	0	35	3	0	84	995
5:40 PM	0	0	0	0	2	0	6	0	11	31	1	0	0	29	8	0	88	1010
5:45 PM	0	0	0	0	3	0	6	0	9	17	2	0	0	21	9	0	67	997
5:50 PM	2	0	0	0	0	0	7	0	9	17	2	0	0	28	6	0	71	991
5:55 PM	0	0	0	0	3	0	4	0	9	32	2	0	0	16	3	0	69	983
Peak 15-Min Flowrates	Northbound				Southbound				Eastbound				Westbound				Total	
	Left	Thru	Right	U	Left	Thru	Right	U	Left	Thru	Right	U	Left	Thru	Right	U		
All Vehicles	8	0	0	0	44	4	60	0	100	364	32	0	0	416	64	0	1092	
Heavy Trucks	0	0	0	0	0	0	4	0	0	0	0	0	0	20	0	0	24	
Pedestrians	0	0	0	0	0	0	0	0	0	0	0	0	0	0	0	0	0	
Bicycles	0	0	0	0	0	0	0	0	0	0	0	0	0	0	0	0	0	
Railroad																		
Stopped Buses																		

Comments:

**LOCATION:** SW Timbrel Ln -- SW Sunset Blvd  
**CITY/STATE:** Sherwood, OR

**QC JOB #:** 14538804  
**DATE:** Thu, Oct 12 2017

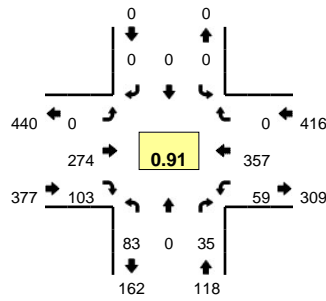

**Peak-Hour: 4:45 PM -- 5:45 PM**  
**Peak 15-Min: 5:15 PM -- 5:30 PM**

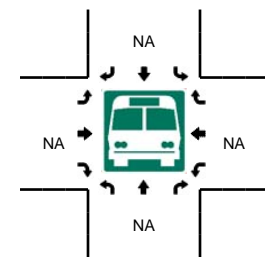
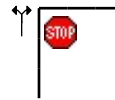
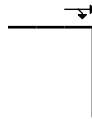
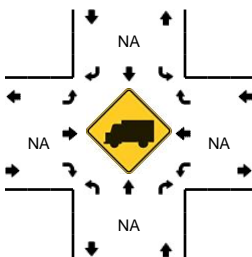
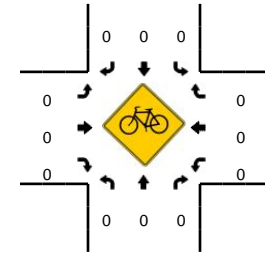
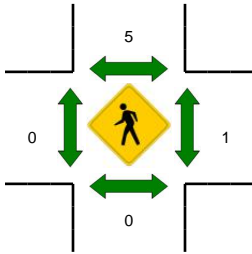
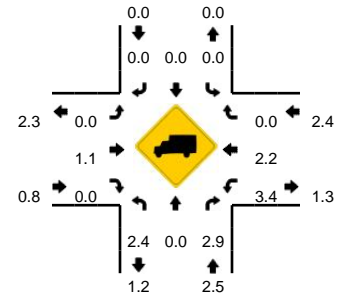

5-Min Count Period Beginning At	SW Timbrel Ln (Northbound)				SW Timbrel Ln (Southbound)				SW Sunset Blvd (Eastbound)				SW Sunset Blvd (Westbound)				Total	Hourly Totals
	Left	Thru	Right	U	Left	Thru	Right	U	Left	Thru	Right	U	Left	Thru	Right	U		
4:00 PM	5	0	2	0	0	0	0	0	0	15	5	0	1	17	0	0	45	
4:05 PM	6	0	0	0	0	0	0	0	0	21	5	0	0	16	0	0	48	
4:10 PM	1	0	1	0	0	0	0	0	0	13	9	0	5	24	0	0	53	
4:15 PM	10	0	1	0	0	0	0	0	0	21	3	0	4	26	0	0	65	
4:20 PM	12	0	7	0	0	0	0	0	0	18	3	0	2	18	0	0	60	
4:25 PM	9	0	4	0	0	0	0	0	0	15	5	0	4	21	0	0	58	
4:30 PM	5	0	4	0	0	0	0	0	0	16	6	0	4	21	0	0	56	
4:35 PM	4	0	2	0	0	0	0	0	0	25	8	0	4	22	0	0	65	
4:40 PM	3	0	4	0	0	0	0	0	0	20	10	0	3	29	0	0	69	
4:45 PM	14	0	1	0	0	0	0	0	0	17	12	0	4	21	0	0	69	
4:50 PM	7	0	2	0	0	0	0	0	0	17	8	0	5	25	0	0	64	
4:55 PM	10	0	2	0	0	0	0	0	0	27	2	0	4	34	0	0	79	731
5:00 PM	3	0	5	0	0	0	0	0	0	24	12	0	6	25	0	0	75	761
5:05 PM	4	0	2	0	0	0	0	0	0	33	3	0	8	32	0	0	82	795
5:10 PM	8	0	1	0	0	0	0	0	0	15	11	0	4	29	0	0	68	810
5:15 PM	6	0	3	0	0	0	0	0	0	18	10	0	8	37	0	0	82	827
5:20 PM	8	0	6	0	0	0	0	0	0	31	7	0	4	38	0	0	94	861
5:25 PM	4	0	5	0	0	0	0	0	0	22	13	0	3	26	0	0	73	876
5:30 PM	7	0	2	0	0	0	0	0	0	25	7	0	7	27	0	0	75	895
5:35 PM	7	0	4	0	0	0	0	0	0	24	5	0	3	32	0	0	75	905
5:40 PM	5	0	2	0	0	0	0	0	0	21	13	0	3	31	0	0	75	911
5:45 PM	6	0	1	0	0	0	0	0	0	14	4	0	4	23	0	0	52	894
5:50 PM	9	0	1	0	0	0	0	0	0	13	7	0	6	26	0	0	62	892
5:55 PM	3	0	1	0	0	0	0	0	0	22	7	0	3	15	0	0	51	864
Peak 15-Min Flowrates	Northbound				Southbound				Eastbound				Westbound				Total	
	Left	Thru	Right	U	Left	Thru	Right	U	Left	Thru	Right	U	Left	Thru	Right	U		
All Vehicles	72	0	56	0	0	0	0	0	0	284	120	0	60	404	0	0	996	
Heavy Trucks	4	0	4	0	0	0	0	0	0	0	0	0	0	16	0	0	24	
Pedestrians	0	0	0	0	0	4	0	0	0	0	0	0	0	4	0	0	8	
Bicycles	0	0	0	0	0	0	0	0	0	0	0	0	0	0	0	0	0	
Railroad																		
Stopped Buses																		

Comments:

**LOCATION:** SW Main St/SW Ladd Hill Rd -- SW Sunset Blvd  
**CITY/STATE:** Sherwood, OR

**QC JOB #:** 14487602  
**DATE:** Tue, Sep 12 2017

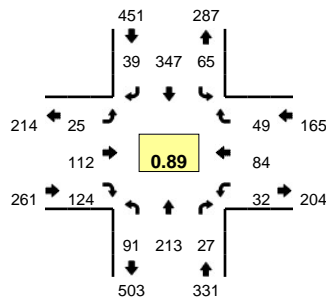

**Peak-Hour: 4:40 PM -- 5:40 PM**  
**Peak 15-Min: 5:15 PM -- 5:30 PM**

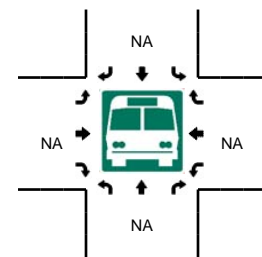
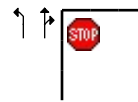
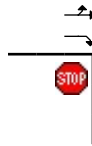
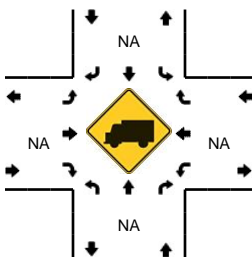
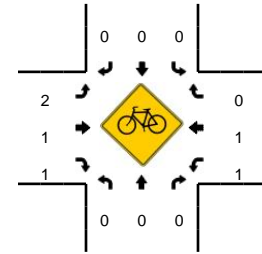
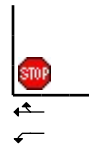
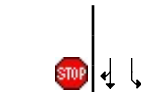
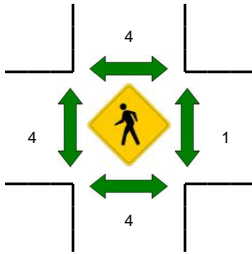
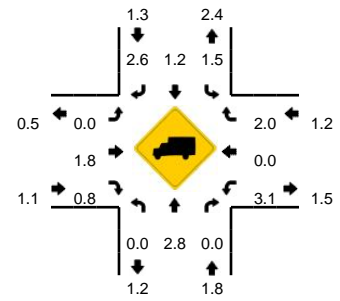

5-Min Count Period Beginning At	SW Main St/SW Ladd Hill Rd (Northbound)				SW Main St/SW Ladd Hill Rd (Southbound)				SW Sunset Blvd (Eastbound)				SW Sunset Blvd (Westbound)				Total	Hourly Totals
	Left	Thru	Right	U	Left	Thru	Right	U	Left	Thru	Right	U	Left	Thru	Right	U		
4:00 PM	2	12	3	0	5	22	2	0	1	5	8	0	3	3	2	0	68	
4:05 PM	5	10	2	0	7	18	1	0	3	5	14	0	4	4	3	0	76	
4:10 PM	6	10	2	0	1	25	2	0	3	7	9	0	3	5	3	0	76	
4:15 PM	1	8	3	0	6	19	2	0	3	6	8	0	2	3	1	0	62	
4:20 PM	7	14	3	0	6	21	2	0	1	3	8	0	2	3	2	1	73	
4:25 PM	6	13	1	0	5	20	3	0	4	4	7	0	3	5	4	0	75	
4:30 PM	10	14	2	0	9	31	4	0	0	5	5	0	2	4	3	0	89	
4:35 PM	2	15	3	0	5	24	3	0	1	7	12	0	2	3	4	0	81	
4:40 PM	3	14	1	0	3	35	6	0	2	10	8	0	4	5	3	0	94	
4:45 PM	2	26	2	0	6	27	4	0	4	10	9	0	2	8	4	0	104	
4:50 PM	10	15	3	0	3	36	2	0	1	6	13	0	1	4	6	0	100	
4:55 PM	3	17	2	0	5	34	4	0	0	10	8	0	3	7	3	0	96	994
5:00 PM	6	17	4	0	6	26	3	0	2	7	10	0	3	12	3	0	99	1025
5:05 PM	6	13	2	0	5	28	7	0	2	10	14	0	2	5	9	0	103	1052
5:10 PM	5	22	2	0	6	23	0	0	1	11	12	0	2	3	4	0	91	1067
5:15 PM	13	18	4	0	5	26	3	0	1	9	10	0	5	9	2	0	105	1110
5:20 PM	13	27	0	0	9	34	2	0	4	12	12	0	3	8	1	0	125	1162
5:25 PM	17	14	1	0	8	29	1	0	5	8	13	0	1	11	1	0	109	1196
5:30 PM	7	17	5	0	2	27	2	0	2	8	11	0	1	6	6	0	94	1201
5:35 PM	6	13	1	0	7	22	5	0	1	11	4	0	5	6	7	0	88	1208
5:40 PM	12	20	2	0	3	19	2	0	1	10	7	0	1	3	2	0	82	1196
5:45 PM	6	22	1	0	2	20	4	0	3	5	9	0	5	5	5	0	87	1179
5:50 PM	6	11	1	0	2	30	2	0	2	10	10	0	4	7	1	0	86	1165
5:55 PM	9	22	0	0	4	23	4	0	2	10	13	0	5	4	3	0	99	1168
Peak 15-Min Flowrates	Northbound				Southbound				Eastbound				Westbound				Total	
	Left	Thru	Right	U	Left	Thru	Right	U	Left	Thru	Right	U	Left	Thru	Right	U		
All Vehicles	172	236	20	0	88	356	24	0	40	116	140	0	36	112	16	0	1356	
Heavy Trucks	0	12	0	0	0	0	0	0	0	4	0	0	4	0	0	0	20	
Pedestrians		0				12				0				0			12	
Bicycles	0	0	0		0	0	0		0	0	0		0	1	0		1	
Railroad																		
Stopped Buses																		

Comments:



**LOCATION:** SW Murdock Rd/SW Baker Rd -- SW Sunset Blvd/McKinley Dr  
**CITY/STATE:** Sherwood, OR

**QC JOB #:** 14548502  
**DATE:** Wed, Oct 25 2017

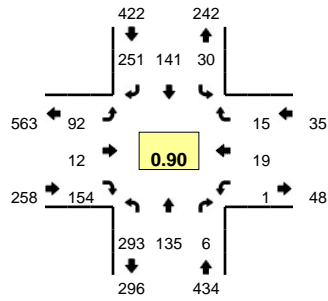

**Peak-Hour: 4:45 PM -- 5:45 PM**  
**Peak 15-Min: 5:05 PM -- 5:20 PM**

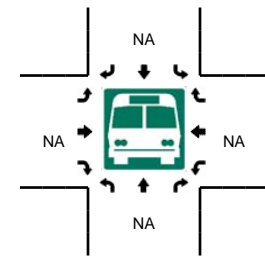
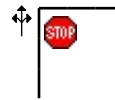
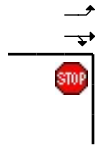
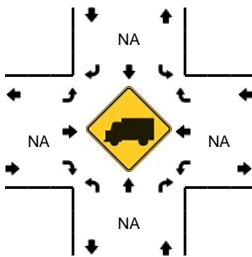
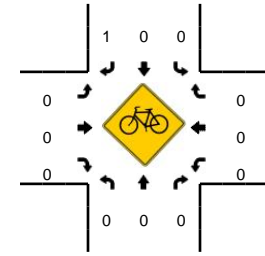
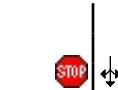
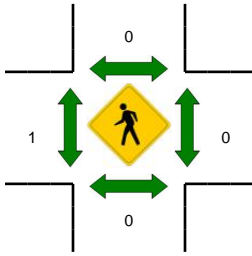
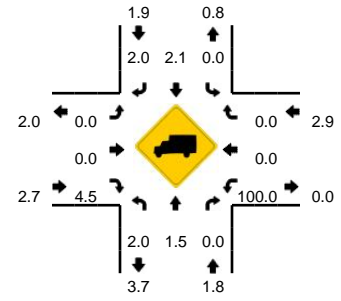

5-Min Count Period Beginning At	SW Murdock Rd/SW Baker Rd (Northbound)				SW Murdock Rd/SW Baker Rd (Southbound)				SW Sunset Blvd/McKinley Dr (Eastbound)				SW Sunset Blvd/McKinley Dr (Westbound)				Total	Hourly Totals
	Left	Thru	Right	U	Left	Thru	Right	U	Left	Thru	Right	U	Left	Thru	Right	U		
4:00 PM	16	9	0	0	1	8	14	0	10	0	10	0	0	2	1	0	71	
4:05 PM	13	11	0	0	2	10	17	0	8	2	12	0	0	0	0	0	75	
4:10 PM	16	11	0	0	4	11	18	0	4	3	9	0	0	0	0	0	76	
4:15 PM	21	6	0	0	3	8	16	0	9	0	7	0	0	1	0	0	71	
4:20 PM	14	7	1	0	1	15	23	0	8	0	9	0	0	0	1	0	79	
4:25 PM	24	6	1	0	1	5	12	0	7	1	2	0	0	0	0	0	59	
4:30 PM	19	12	0	0	1	13	10	0	6	0	16	0	0	1	0	0	78	
4:35 PM	14	8	0	0	1	14	18	0	7	0	13	0	0	0	0	0	75	
4:40 PM	24	11	1	0	1	11	16	0	2	0	10	0	0	0	0	0	76	
4:45 PM	25	13	0	0	0	17	28	0	12	0	9	0	0	2	1	0	107	
4:50 PM	26	12	0	0	2	11	27	0	6	1	17	0	0	2	3	0	107	
4:55 PM	25	14	1	0	3	8	26	0	11	1	10	0	0	1	2	0	102	976
5:00 PM	14	9	1	0	1	12	14	0	5	0	11	0	0	1	3	0	71	976
5:05 PM	25	13	0	0	5	11	19	0	9	1	17	0	0	2	0	0	102	1003
5:10 PM	34	14	1	0	5	14	15	0	6	2	16	0	1	4	0	0	112	1039
5:15 PM	19	14	0	0	5	14	22	0	9	0	16	0	0	2	3	0	104	1072
5:20 PM	29	4	1	0	0	6	20	0	4	3	10	0	0	1	1	0	79	1072
5:25 PM	27	6	0	0	5	14	17	0	10	2	14	0	0	0	0	0	95	1108
5:30 PM	20	12	1	0	2	12	21	0	9	0	16	0	0	1	2	0	96	1126
5:35 PM	23	10	1	0	1	9	20	0	5	1	7	0	0	1	0	0	78	1129
5:40 PM	26	14	0	0	1	13	22	0	6	1	11	0	0	2	0	0	96	1149
5:45 PM	21	11	0	0	0	15	16	0	6	0	10	0	0	0	2	0	81	1123
5:50 PM	20	7	0	0	3	8	16	0	9	2	10	0	0	0	0	0	75	1091
5:55 PM	15	9	0	0	2	9	20	0	6	1	8	0	0	0	2	0	72	1061
Peak 15-Min Flowrates	Northbound				Southbound				Eastbound				Westbound				Total	
	Left	Thru	Right	U	Left	Thru	Right	U	Left	Thru	Right	U	Left	Thru	Right	U		
All Vehicles	312	164	4	0	60	156	224	0	96	12	196	0	4	32	12	0	1272	
Heavy Trucks	8	0	0		0	8	0		0	0	8		4	0	0		28	
Pedestrians		0				0				0				0			0	
Bicycles		0				0		1			0			0			1	
Railroad																		
Stopped Buses																		

Comments:

**LOCATION:** SW Pacific Hwy -- SW Chapman Rd  
**CITY/STATE:** Sherwood, OR

**QC JOB #:** 14401707  
**DATE:** Thu, May 11 2017

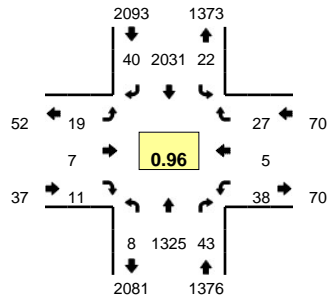

**Peak-Hour: 4:35 PM -- 5:35 PM**  
**Peak 15-Min: 5:10 PM -- 5:25 PM**

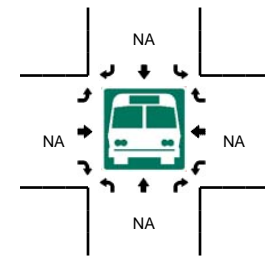
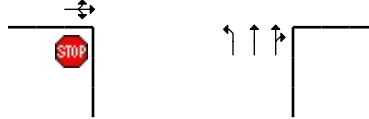
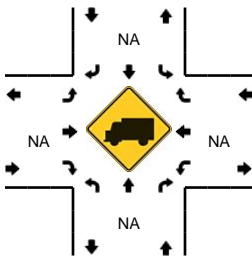
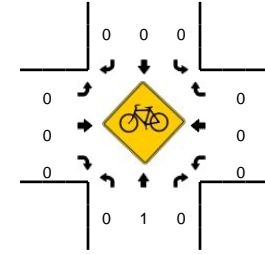
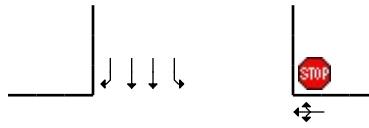
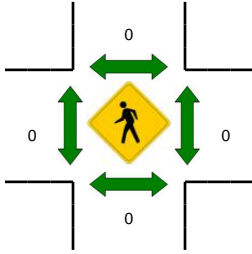
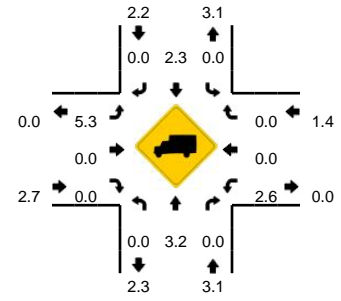

5-Min Count Period Beginning At	SW Pacific Hwy (Northbound)				SW Pacific Hwy (Southbound)				SW Chapman Rd (Eastbound)				SW Chapman Rd (Westbound)				Total	Hourly Totals
	Left	Thru	Right	U	Left	Thru	Right	U	Left	Thru	Right	U	Left	Thru	Right	U		
4:00 PM	0	89	1	0	1	184	2	0	1	1	0	0	2	0	0	0	281	
4:05 PM	0	72	6	1	0	166	3	0	0	0	1	0	5	0	0	0	254	
4:10 PM	1	103	2	1	1	160	1	0	1	0	1	0	3	0	1	0	275	
4:15 PM	0	126	4	0	1	163	4	0	4	0	0	0	4	0	2	0	308	
4:20 PM	0	124	1	0	1	153	1	0	1	0	0	0	4	0	0	0	285	
4:25 PM	1	92	5	0	1	172	4	0	1	0	0	0	4	0	2	0	282	
4:30 PM	1	102	2	0	3	149	0	0	0	0	0	0	4	0	2	0	263	
4:35 PM	2	114	0	0	1	153	3	0	2	2	0	0	1	0	4	0	282	
4:40 PM	0	117	2	0	3	149	4	0	5	1	3	0	6	0	4	0	294	
4:45 PM	0	108	2	0	0	176	3	0	3	1	1	0	3	0	5	0	302	
4:50 PM	0	117	5	0	2	177	4	0	0	1	1	0	4	1	1	0	313	
4:55 PM	2	121	3	0	1	173	5	0	0	0	1	0	1	0	3	0	310	3449
5:00 PM	0	102	6	0	4	159	1	1	0	0	2	0	3	0	1	0	279	3447
5:05 PM	0	91	2	0	2	183	3	0	1	0	1	0	0	1	0	0	284	3477
5:10 PM	0	110	6	0	4	187	2	1	4	0	0	0	5	0	1	0	320	3522
5:15 PM	2	119	3	0	1	189	5	0	0	1	1	0	2	1	1	0	325	3539
5:20 PM	1	107	1	1	0	161	3	0	2	0	0	0	6	0	5	0	287	3541
5:25 PM	0	114	6	0	2	177	5	0	1	0	1	0	4	0	0	0	310	3569
5:30 PM	0	105	7	0	0	147	2	0	1	1	0	0	3	2	2	0	270	3576
5:35 PM	0	100	0	0	1	164	2	1	1	0	1	0	4	1	2	0	277	3571
5:40 PM	0	132	4	0	0	156	2	0	1	0	1	0	0	0	1	0	297	3574
5:45 PM	0	114	4	0	0	149	1	0	4	0	0	0	5	0	2	0	279	3551
5:50 PM	0	93	3	0	3	158	1	0	0	4	0	0	5	1	1	0	269	3507
5:55 PM	0	82	3	0	2	151	0	0	1	2	0	0	5	0	1	0	247	3444
Peak 15-Min Flowrates	Northbound				Southbound				Eastbound				Westbound				Total	
	Left	Thru	Right	U	Left	Thru	Right	U	Left	Thru	Right	U	Left	Thru	Right	U		
All Vehicles	12	1344	40	4	20	2148	40	4	24	4	4	0	52	4	28	0	3728	
Heavy Trucks	0	44	0		0	40	0		0	0	0		0	0	0		84	
Pedestrians		0				0				0				0			0	
Bicycles	0	1	0		0	0	0		0	0	0		0	0	0		1	
Railroad																		
Stopped Buses																		

Comments:

**LOCATION:** SW Old Hwy 99W -- SW Brookman Rd  
**CITY/STATE:** Sherwood, OR

**QC JOB #:** 14401710  
**DATE:** Thu, May 11 2017

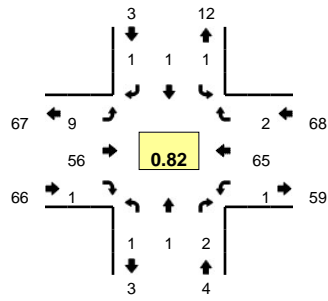

**Peak-Hour: 4:35 PM -- 5:35 PM**  
**Peak 15-Min: 5:05 PM -- 5:20 PM**

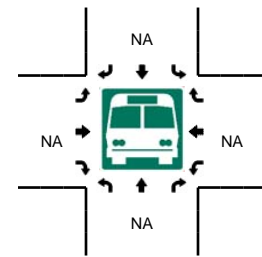
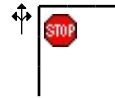
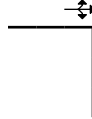
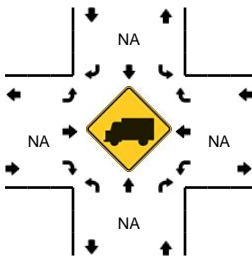
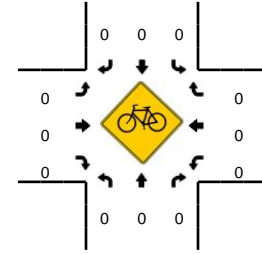
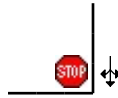
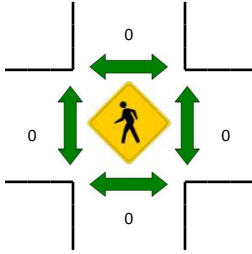
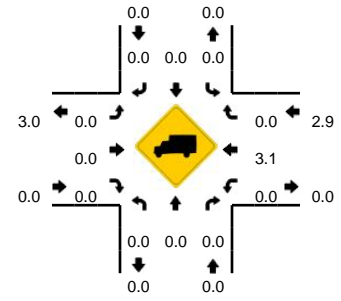

5-Min Count Period Beginning At	SW Old Hwy 99W (Northbound)				SW Old Hwy 99W (Southbound)				SW Brookman Rd (Eastbound)				SW Brookman Rd (Westbound)				Total	Hourly Totals
	Left	Thru	Right	U	Left	Thru	Right	U	Left	Thru	Right	U	Left	Thru	Right	U		
4:00 PM	0	0	0	0	0	0	0	0	2	1	0	0	0	1	0	0	4	
4:05 PM	0	0	1	0	0	0	0	0	0	6	0	0	1	5	0	0	13	
4:10 PM	0	0	0	0	1	0	0	0	0	3	0	0	0	4	0	0	8	
4:15 PM	0	0	0	0	1	0	2	0	2	4	0	0	0	3	0	0	12	
4:20 PM	0	0	0	0	0	0	0	0	0	1	0	0	0	4	0	0	5	
4:25 PM	0	0	0	0	0	0	0	0	1	2	0	0	0	5	0	0	8	
4:30 PM	0	0	0	0	0	0	1	0	1	4	0	0	0	3	0	0	9	
4:35 PM	0	0	0	0	0	0	0	0	0	1	0	0	1	3	1	0	6	
4:40 PM	0	0	0	0	0	0	1	0	1	3	0	0	0	9	0	0	14	
4:45 PM	0	0	0	0	0	0	0	0	0	4	0	0	0	5	0	0	9	
4:50 PM	0	0	0	0	1	0	0	0	1	5	0	0	0	5	0	0	12	
4:55 PM	0	0	0	0	0	0	0	0	0	5	0	0	0	6	0	0	11	
5:00 PM	0	0	0	0	0	1	0	0	4	4	1	0	0	5	0	0	15	111
5:05 PM	0	0	2	0	0	0	0	0	0	6	0	0	0	2	0	0	10	119
5:10 PM	0	1	0	0	0	0	0	0	0	8	0	0	0	4	1	0	14	125
5:15 PM	0	0	0	0	0	0	0	0	2	5	0	0	0	12	0	0	19	132
5:20 PM	0	0	0	0	0	0	0	0	1	1	0	0	0	6	0	0	8	135
5:25 PM	1	0	0	0	0	0	0	0	0	7	0	0	0	2	0	0	10	137
5:30 PM	0	0	0	0	0	0	0	0	0	7	0	0	0	6	0	0	13	141
5:35 PM	0	0	0	0	0	0	0	0	0	1	0	0	0	4	0	0	5	140
5:40 PM	0	0	0	0	0	0	0	0	0	4	0	0	1	1	0	0	6	132
5:45 PM	0	0	0	0	0	0	0	0	1	4	0	0	0	7	0	0	12	135
5:50 PM	0	0	0	0	0	0	0	0	1	7	0	0	0	6	0	0	14	137
5:55 PM	0	0	0	0	0	0	0	0	1	5	0	0	0	5	0	0	11	137
Peak 15-Min Flowrates	Northbound				Southbound				Eastbound				Westbound				Total	
	Left	Thru	Right	U	Left	Thru	Right	U	Left	Thru	Right	U	Left	Thru	Right	U		
All Vehicles	0	4	8	0	0	0	0	0	8	76	0	0	0	72	4	0	172	
Heavy Trucks	0	0	0	0	0	0	0	0	0	0	0	0	0	0	0	0	0	
Pedestrians	0	0	0	0	0	0	0	0	0	0	0	0	0	0	0	0	0	
Bicycles	0	0	0	0	0	0	0	0	0	0	0	0	0	0	0	0	0	
Railroad																		
Stopped Buses																		

Comments:

**LOCATION:** SW Middleton Rd -- SW Brookman Rd  
**CITY/STATE:** Sherwood, OR

**QC JOB #:** 14401712  
**DATE:** Thu, May 11 2017

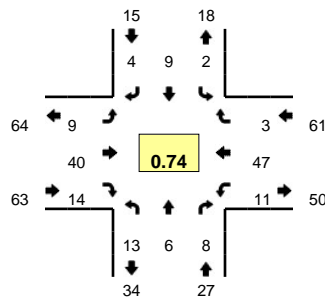

**Peak-Hour: 5:00 PM -- 6:00 PM**  
**Peak 15-Min: 5:05 PM -- 5:20 PM**

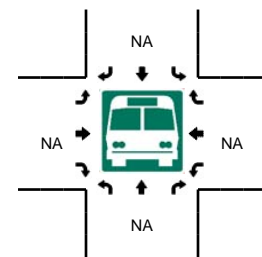
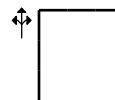
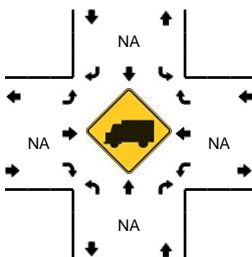
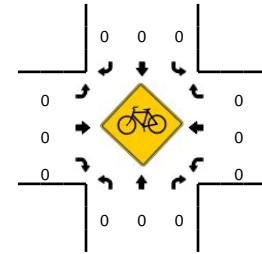
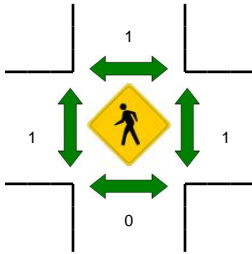
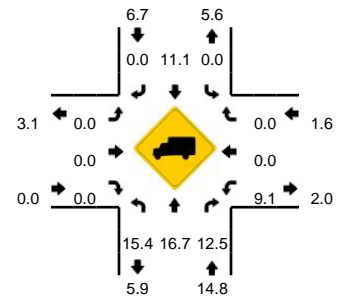

5-Min Count Period Beginning At	SW Middleton Rd (Northbound)				SW Middleton Rd (Southbound)				SW Brookman Rd (Eastbound)				SW Brookman Rd (Westbound)				Total	Hourly Totals	
	Left	Thru	Right	U	Left	Thru	Right	U	Left	Thru	Right	U	Left	Thru	Right	U			
4:00 PM	0	0	0	0	1	0	0	0	0	1	0	0	0	0	2	0	0	4	
4:05 PM	0	0	0	0	0	2	1	0	0	0	7	0	0	0	4	0	0	14	
4:10 PM	1	0	1	0	0	0	0	0	0	1	3	0	0	0	3	0	0	9	
4:15 PM	3	0	0	0	0	0	0	0	0	1	3	1	0	0	1	0	0	9	
4:20 PM	0	0	1	0	0	0	0	0	0	0	1	0	0	0	4	0	0	6	
4:25 PM	0	0	0	0	0	0	0	0	0	0	2	0	0	1	5	0	0	8	
4:30 PM	0	0	0	0	0	0	0	0	0	0	1	2	0	0	2	0	0	5	
4:35 PM	0	0	1	0	1	0	0	0	0	0	2	0	0	0	4	1	0	9	
4:40 PM	3	0	0	0	0	0	0	0	0	0	2	0	0	0	7	0	0	12	
4:45 PM	1	0	0	0	2	0	2	0	1	2	1	0	1	4	0	0	14		
4:50 PM	2	0	0	0	0	1	1	0	0	0	6	1	0	1	2	1	0	15	
4:55 PM	0	0	0	0	0	0	0	0	0	0	5	0	0	1	3	0	0	9	114
5:00 PM	2	0	1	0	0	0	1	0	0	0	4	0	0	0	2	0	0	10	120
5:05 PM	0	0	1	0	0	1	0	0	0	0	7	1	0	1	3	0	0	14	120
5:10 PM	1	1	1	0	1	3	0	0	0	0	4	1	0	0	5	0	0	17	128
5:15 PM	2	2	0	0	0	1	0	0	0	1	4	3	0	2	10	0	0	25	144
5:20 PM	2	0	1	0	0	0	0	0	0	0	0	0	0	3	3	1	0	10	148
5:25 PM	0	0	1	0	0	0	0	0	2	5	1	0	0	0	3	0	0	12	152
5:30 PM	1	1	0	0	0	0	1	0	3	3	1	0	0	0	5	0	0	15	162
5:35 PM	1	0	1	0	0	1	0	0	0	1	1	1	0	1	2	0	0	8	161
5:40 PM	2	1	1	0	0	2	0	0	1	1	0	0	2	1	1	0	12	161	
5:45 PM	1	1	1	0	0	0	2	0	2	3	1	0	1	3	1	0	16	163	
5:50 PM	0	0	0	0	1	0	0	0	0	4	3	0	1	7	0	0	16	164	
5:55 PM	1	0	0	0	0	1	0	0	0	4	2	0	0	3	0	0	11	166	
Peak 15-Min Flowrates	Northbound				Southbound				Eastbound				Westbound				Total		
	Left	Thru	Right	U	Left	Thru	Right	U	Left	Thru	Right	U	Left	Thru	Right	U			
All Vehicles	12	12	8	0	4	20	0	0	4	60	20	0	12	72	0	0	224		
Heavy Trucks	0	0	4		0	0	0		0	0	0		0	0	0		4		
Pedestrians	0				0				0				0				0		
Bicycles	0	0	0		0	0	0		0	0	0		0	0	0		0		
Railroad																			
Stopped Buses																			

Comments:

**LOCATION:** SW Oberst Rd -- SW Brookman Rd  
**CITY/STATE:** Sherwood, OR

**QC JOB #:** 14401714  
**DATE:** Thu, May 11 2017

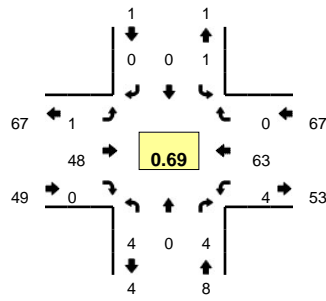

**Peak-Hour: 4:55 PM -- 5:55 PM**  
**Peak 15-Min: 5:05 PM -- 5:20 PM**

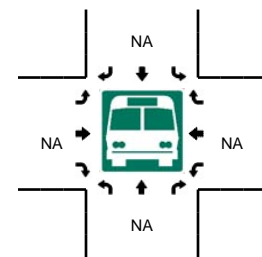
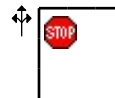
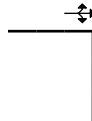
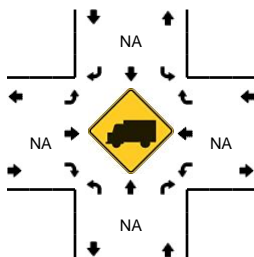
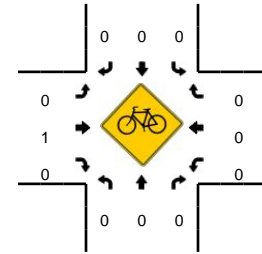
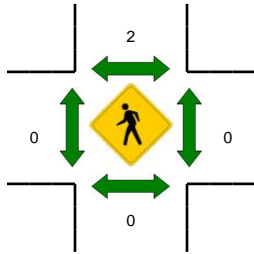
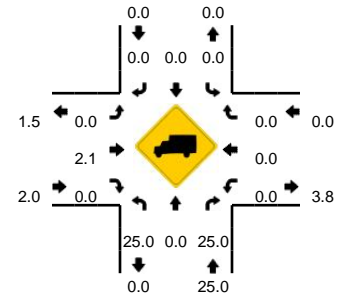

5-Min Count Period Beginning At	SW Oberst Rd (Northbound)				SW Oberst Rd (Southbound)				SW Brookman Rd (Eastbound)				SW Brookman Rd (Westbound)				Total	Hourly Totals	
	Left	Thru	Right	U	Left	Thru	Right	U	Left	Thru	Right	U	Left	Thru	Right	U			
4:00 PM	0	0	0	0	0	0	0	0	0	0	3	0	0	0	1	0	0	4	
4:05 PM	0	0	0	0	0	0	0	0	0	0	6	0	0	0	6	0	0	12	
4:10 PM	0	0	0	0	0	0	0	0	0	0	3	1	0	0	2	0	0	6	
4:15 PM	0	0	0	0	0	0	0	0	0	0	3	0	0	0	1	0	0	4	
4:20 PM	0	0	0	0	0	0	0	0	0	0	3	0	0	0	5	0	0	8	
4:25 PM	0	0	0	0	0	0	0	0	0	0	2	0	0	0	5	1	0	8	
4:30 PM	0	0	0	0	0	0	1	0	0	0	0	1	0	0	4	0	0	6	
4:35 PM	0	0	0	0	0	0	0	0	0	0	3	0	0	0	5	0	0	8	
4:40 PM	0	0	0	0	0	0	0	0	0	0	2	1	0	0	6	0	0	9	
4:45 PM	1	0	0	0	0	0	0	0	0	0	1	1	0	0	6	0	0	9	
4:50 PM	0	0	0	0	0	0	0	0	0	0	7	1	0	1	2	0	0	11	
4:55 PM	0	0	0	0	0	0	0	0	0	0	4	0	0	0	5	0	0	9	94
5:00 PM	1	0	1	0	0	0	0	0	0	0	3	0	0	0	3	0	0	8	98
5:05 PM	0	0	0	0	0	0	0	0	0	1	7	0	0	0	4	0	0	12	98
5:10 PM	0	0	0	0	0	0	0	0	0	0	7	0	0	3	4	0	0	14	106
5:15 PM	0	0	0	0	0	0	0	0	0	0	5	0	0	1	13	0	0	19	121
5:20 PM	2	0	0	0	0	0	0	0	0	0	0	0	0	0	4	0	0	6	119
5:25 PM	0	0	1	0	0	0	0	0	0	0	5	0	0	0	3	0	0	9	120
5:30 PM	0	0	0	0	1	0	0	0	0	0	3	0	0	0	5	0	0	9	123
5:35 PM	0	0	0	0	0	0	0	0	0	0	3	0	0	0	5	0	0	8	123
5:40 PM	0	0	0	0	0	0	0	0	0	0	3	0	0	0	3	0	0	6	120
5:45 PM	0	0	1	0	0	0	0	0	0	0	3	0	0	0	5	0	0	9	120
5:50 PM	1	0	1	0	0	0	0	0	0	0	5	0	0	0	9	0	0	16	125
5:55 PM	0	0	0	0	0	0	0	0	0	0	4	0	0	1	2	0	0	7	123
Peak 15-Min Flowrates	Northbound				Southbound				Eastbound				Westbound				Total		
	Left	Thru	Right	U	Left	Thru	Right	U	Left	Thru	Right	U	Left	Thru	Right	U			
All Vehicles	0	0	0	0	0	0	0	0	4	76	0	0	16	84	0	0	180		
Heavy Trucks	0	0	0	0	0	0	0	0	0	4	0	0	0	0	0	0	4		
Pedestrians	0	0	0	0	0	4	0	0	0	0	0	0	0	0	0	0	4		
Bicycles	0	0	0	0	0	0	0	0	0	0	0	0	0	0	0	0	0		
Railroad																			
Stopped Buses																			

Comments:

**LOCATION:** SW Ladd Hill Rd -- SW Brookman Rd  
**CITY/STATE:** Sherwood, OR

**QC JOB #:** 14401716  
**DATE:** Thu, May 11 2017

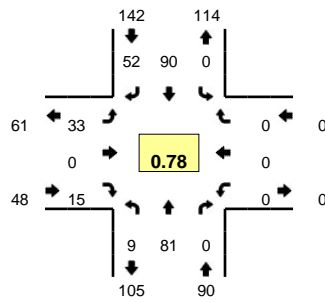

**Peak-Hour: 4:45 PM -- 5:45 PM**  
**Peak 15-Min: 5:05 PM -- 5:20 PM**

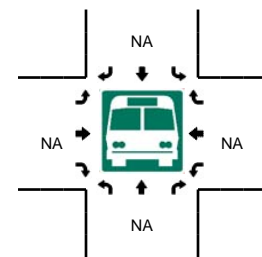
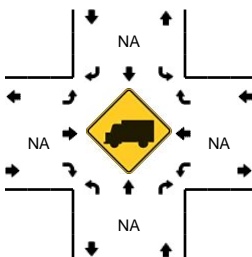
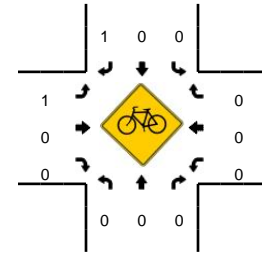
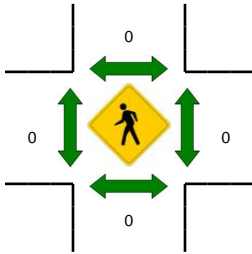
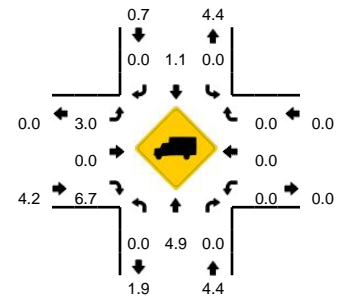

5-Min Count Period Beginning At	SW Ladd Hill Rd (Northbound)				SW Ladd Hill Rd (Southbound)				SW Brookman Rd (Eastbound)				SW Brookman Rd (Westbound)				Total	Hourly Totals
	Left	Thru	Right	U	Left	Thru	Right	U	Left	Thru	Right	U	Left	Thru	Right	U		
4:00 PM	0	7	0	0	0	6	3	0	1	0	1	0	0	0	0	0	18	
4:05 PM	2	4	0	0	0	3	4	0	2	0	2	0	0	0	0	0	17	
4:10 PM	1	6	0	0	0	4	0	0	4	0	1	0	0	0	0	0	16	
4:15 PM	1	5	0	0	0	10	0	0	2	0	1	0	0	0	0	0	19	
4:20 PM	2	7	0	0	0	3	5	0	2	0	1	0	0	0	0	0	20	
4:25 PM	1	10	0	0	0	4	6	0	0	0	0	0	0	0	0	0	21	
4:30 PM	2	4	0	0	0	5	1	0	1	0	1	0	0	0	0	0	14	
4:35 PM	1	7	0	0	0	5	2	0	2	0	0	0	0	0	0	0	17	
4:40 PM	2	4	0	0	0	5	4	0	2	0	0	0	0	0	0	0	17	
4:45 PM	2	9	0	0	0	8	3	0	1	0	2	0	0	0	0	0	25	
4:50 PM	1	1	0	0	0	7	4	0	2	0	1	0	0	0	0	0	16	
4:55 PM	0	8	0	0	0	6	5	0	4	0	1	0	0	0	0	0	24	224
5:00 PM	0	7	0	0	0	2	1	0	5	0	0	0	0	0	0	0	15	221
5:05 PM	1	10	0	0	0	11	7	0	2	0	1	0	0	0	0	0	32	236
5:10 PM	2	5	0	0	0	8	7	0	6	0	2	0	0	0	0	0	30	250
5:15 PM	2	9	0	0	0	5	6	0	3	0	3	0	0	0	0	0	28	259
5:20 PM	0	7	0	0	0	10	5	0	0	0	0	0	0	0	0	0	22	261
5:25 PM	1	5	0	0	0	14	4	0	3	0	1	0	0	0	0	0	28	268
5:30 PM	0	6	0	0	0	5	2	0	3	0	2	0	0	0	0	0	18	272
5:35 PM	0	5	0	0	0	5	4	0	2	0	1	0	0	0	0	0	17	272
5:40 PM	0	9	0	0	0	9	4	0	2	0	1	0	0	0	0	0	25	280
5:45 PM	1	3	0	0	0	5	9	0	3	0	1	0	0	0	0	0	22	277
5:50 PM	1	4	0	0	0	2	5	0	4	0	0	0	0	0	0	0	16	277
5:55 PM	0	4	0	0	0	9	2	0	5	0	2	0	0	0	0	0	22	275
Peak 15-Min Flowrates	Northbound				Southbound				Eastbound				Westbound				Total	
	Left	Thru	Right	U	Left	Thru	Right	U	Left	Thru	Right	U	Left	Thru	Right	U		
All Vehicles	20	96	0	0	0	96	80	0	44	0	24	0	0	0	0	0	360	
Heavy Trucks	0	4	0	0	0	4	0	0	4	0	4	0	0	0	0	0	16	
Pedestrians		0				0				0				0			0	
Bicycles	0	0	0		0	0	1		0	0	0		0	0	0		1	
Railroad																		
Stopped Buses																		

Comments:

Appendix D Existing Conditions  
Level of Service Worksheets

# HCM Signalized Intersection Capacity Analysis

## 101: SW Pacific Hwy & SW Elwert Rd/SW Sunset Blvd

01/30/2019



Movement	EBL	EBT	EBR	WBL	WBT	WBR	NBL	NBT	NBR	SBL	SBT	SBR
Lane Configurations		↕	↗		↕	↗	↗	↕↕	↗	↗↗	↕↕	↗
Traffic Volume (vph)	18	106	223	102	179	225	245	1580	106	128	766	13
Future Volume (vph)	18	106	223	102	179	225	245	1580	106	128	766	13
Ideal Flow (vphpl)	1900	1900	1900	1900	1900	1900	1900	1900	1900	1900	1900	1900
Grade (%)		0%			0%			-1%				2%
Total Lost time (s)		6.0	6.0		6.0	6.0	5.0	6.0	6.0	5.0	6.0	6.0
Lane Util. Factor		1.00	1.00		1.00	1.00	1.00	0.95	1.00	0.97	0.95	1.00
Frbp, ped/bikes		1.00	1.00		1.00	1.00	1.00	1.00	1.00	1.00	1.00	0.98
Flpb, ped/bikes		1.00	1.00		1.00	1.00	1.00	1.00	1.00	1.00	1.00	1.00
Frt		1.00	0.85		1.00	0.85	1.00	1.00	0.85	1.00	1.00	0.85
Flt Protected		0.99	1.00		0.98	1.00	0.95	1.00	1.00	0.95	1.00	1.00
Satd. Flow (prot)		1809	1583		1818	1553	1761	3489	1561	3180	3279	1361
Flt Permitted		0.91	1.00		0.79	1.00	0.95	1.00	1.00	0.95	1.00	1.00
Satd. Flow (perm)		1667	1583		1471	1553	1761	3489	1561	3180	3279	1361
Peak-hour factor, PHF	0.95	0.95	0.95	0.95	0.95	0.95	0.95	0.95	0.95	0.95	0.95	0.95
Adj. Flow (vph)	19	112	235	107	188	237	258	1663	112	135	806	14
RTOR Reduction (vph)	0	0	171	0	0	109	0	0	27	0	0	8
Lane Group Flow (vph)	0	131	64	0	295	128	258	1663	85	135	806	6
Confl. Bikes (#/hr)												1
Heavy Vehicles (%)	0%	5%	2%	2%	3%	4%	3%	4%	4%	9%	9%	15%
Turn Type	Perm	NA	Perm	Perm	NA	Perm	Prot	NA	Perm	Prot	NA	Perm
Protected Phases		4			8		5	2		1		6
Permitted Phases	4		4	8		8			2			6
Actuated Green, G (s)		35.0	35.0		35.0	35.0	23.8	65.1	65.1	11.2	52.5	52.5
Effective Green, g (s)		35.0	35.0		35.0	35.0	23.8	65.1	65.1	11.2	52.5	52.5
Actuated g/C Ratio		0.27	0.27		0.27	0.27	0.19	0.51	0.51	0.09	0.41	0.41
Clearance Time (s)		6.0	6.0		6.0	6.0	5.0	6.0	6.0	5.0	6.0	6.0
Vehicle Extension (s)		3.0	3.0		3.0	3.0	3.0	5.4	5.4	3.5	5.4	5.4
Lane Grp Cap (vph)		454	431		401	423	326	1770	792	277	1341	556
v/s Ratio Prot							c0.15	c0.48		0.04	0.25	
v/s Ratio Perm		0.08	0.04		c0.20	0.08			0.05			0.00
v/c Ratio		0.29	0.15		0.74	0.30	0.79	0.94	0.11	0.49	0.60	0.01
Uniform Delay, d1		36.8	35.4		42.4	37.0	49.9	29.7	16.5	55.8	29.7	22.5
Progression Factor		1.00	1.00		1.00	1.00	1.00	1.00	1.00	1.00	1.00	1.00
Incremental Delay, d2		0.4	0.2		6.9	0.4	12.3	10.7	0.1	1.6	1.2	0.0
Delay (s)		37.2	35.5		49.3	37.4	62.2	40.4	16.6	57.4	30.9	22.5
Level of Service		D	D		D	D	E	D	B	E	C	C
Approach Delay (s)		36.1			44.0			41.9			34.5	
Approach LOS		D			D			D			C	

### Intersection Summary

HCM 2000 Control Delay	39.8	HCM 2000 Level of Service	D
HCM 2000 Volume to Capacity ratio	0.88		
Actuated Cycle Length (s)	128.3	Sum of lost time (s)	17.0
Intersection Capacity Utilization	83.2%	ICU Level of Service	E
Analysis Period (min)	15		
c Critical Lane Group			



HCM Unsignalized Intersection Capacity Analysis  
 102: SW Woodhaven Dr & SW Sunset Blvd

01/30/2019



Movement	EBL	EBT	EBR	WBL	WBT	WBR	NBL	NBT	NBR	SBL	SBT	SBR
Lane Configurations												
Traffic Volume (veh/h)	51	238	41	7	410	86	17	14	10	27	44	67
Future Volume (Veh/h)	51	238	41	7	410	86	17	14	10	27	44	67
Sign Control		Free			Free			Stop			Stop	
Grade		-1%			1%			-2%			0%	
Peak Hour Factor	0.80	0.80	0.80	0.80	0.80	0.80	0.80	0.80	0.80	0.80	0.80	0.80
Hourly flow rate (vph)	64	298	51	9	513	108	21	18	13	34	55	84
Pedestrians					5							3
Lane Width (ft)					12.0						12.0	
Walking Speed (ft/s)					3.5						3.5	
Percent Blockage					0						0	
Right turn flare (veh)												
Median type		None			None							
Median storage (veh)												
Upstream signal (ft)		648										
pX, platoon unblocked												
vC, conflicting volume	624			349			1068	1068	303	1041	1065	570
vC1, stage 1 conf vol												
vC2, stage 2 conf vol												
vCu, unblocked vol	624			349			1068	1068	303	1041	1065	570
tC, single (s)	4.2			4.2			7.1	6.5	6.2	7.2	6.5	6.2
tC, 2 stage (s)												
tF (s)	2.3			2.3			3.5	4.0	3.3	3.6	4.0	3.3
p0 queue free %	93			99			83	91	98	80	73	84
cM capacity (veh/h)	926			1146			127	206	738	174	207	523
<b>Direction, Lane #</b>	<b>EB 1</b>	<b>EB 2</b>	<b>EB 3</b>	<b>WB 1</b>	<b>WB 2</b>	<b>NB 1</b>	<b>SB 1</b>					
Volume Total	64	298	51	9	621	52	173					
Volume Left	64	0	0	9	0	21	34					
Volume Right	0	0	51	0	108	13	84					
cSH	926	1700	1700	1146	1700	192	278					
Volume to Capacity	0.07	0.18	0.03	0.01	0.37	0.27	0.62					
Queue Length 95th (ft)	6	0	0	1	0	26	96					
Control Delay (s)	9.2	0.0	0.0	8.2	0.0	30.6	37.1					
Lane LOS	A			A		D	E					
Approach Delay (s)	1.4			0.1		30.6	37.1					
Approach LOS						D	E					
<b>Intersection Summary</b>												
Average Delay			6.8									
Intersection Capacity Utilization			48.8%			ICU Level of Service			A			
Analysis Period (min)			15									

HCM Unsignalized Intersection Capacity Analysis  
 103: SW Timbrel Ln & SW Sunset Blvd

01/30/2019



Movement	EBT	EBR	WBL	WBT	NBL	NBR
Lane Configurations	↻		↻	↻	↻	
Traffic Volume (veh/h)	208	67	71	321	182	45
Future Volume (Veh/h)	208	67	71	321	182	45
Sign Control	Free			Free	Stop	
Grade	-1%			1%	0%	
Peak Hour Factor	0.84	0.84	0.84	0.84	0.84	0.84
Hourly flow rate (vph)	248	80	85	382	217	54
Pedestrians				21	1	
Lane Width (ft)				12.0	12.0	
Walking Speed (ft/s)				3.5	3.5	
Percent Blockage				2	0	
Right turn flare (veh)						
Median type	None			None		
Median storage (veh)						
Upstream signal (ft)	1264					
pX, platoon unblocked						
vC, conflicting volume			329	841		310
vC1, stage 1 conf vol						
vC2, stage 2 conf vol						
vCu, unblocked vol			329	841		310
tC, single (s)			4.2	6.4		6.3
tC, 2 stage (s)						
tF (s)			2.3	3.5		3.4
p0 queue free %			93	29		92
cM capacity (veh/h)			1207	307		704

Direction, Lane #	EB 1	WB 1	WB 2	NB 1
Volume Total	328	85	382	271
Volume Left	0	85	0	217
Volume Right	80	0	0	54
cSH	1700	1207	1700	346
Volume to Capacity	0.19	0.07	0.22	0.78
Queue Length 95th (ft)	0	6	0	161
Control Delay (s)	0.0	8.2	0.0	44.3
Lane LOS	A		E	
Approach Delay (s)	0.0	1.5	44.3	
Approach LOS	E			

Intersection Summary			
Average Delay	11.9		
Intersection Capacity Utilization	42.3%	ICU Level of Service	A
Analysis Period (min)	15		

HCM Unsignalized Intersection Capacity Analysis  
 104: SW Main St/SW Ladd Hill Rd & SW Sunset Blvd

01/30/2019



Movement	EBL	EBT	EBR	WBL	WBT	WBR	NBL	NBT	NBR	SBL	SBT	SBR
Lane Configurations												
Sign Control		Stop			Stop			Stop			Stop	
Traffic Volume (vph)	106	244	24	30	171	30	71	127	65	28	37	101
Future Volume (vph)	106	244	24	30	171	30	71	127	65	28	37	101
Peak Hour Factor	0.90	0.90	0.90	0.90	0.90	0.90	0.90	0.90	0.90	0.90	0.90	0.90
Hourly flow rate (vph)	118	271	27	33	190	33	79	141	72	31	41	112

Direction, Lane #	EB 1	EB 2	WB 1	WB 2	NB 1	NB 2	SB 1	SB 2
Volume Total (vph)	118	298	33	223	79	213	31	153
Volume Left (vph)	118	0	33	0	79	0	31	0
Volume Right (vph)	0	27	0	33	0	72	0	112
Hadj (s)	0.58	-0.03	0.72	-0.07	0.55	-0.18	0.50	-0.46
Departure Headway (s)	6.9	6.3	7.3	6.5	7.2	6.5	7.4	6.4
Degree Utilization, x	0.23	0.52	0.07	0.40	0.16	0.39	0.06	0.27
Capacity (veh/h)	495	550	465	527	469	522	451	520
Control Delay (s)	10.7	14.8	9.6	12.6	10.4	12.3	9.7	10.6
Approach Delay (s)	13.6		12.2		11.8		10.5	
Approach LOS	B		B		B		B	

Intersection Summary

Delay	12.3
Level of Service	B
Intersection Capacity Utilization	49.2%
ICU Level of Service	A
Analysis Period (min)	15

HCM Unsignalized Intersection Capacity Analysis  
 105: SW Baker Rd/SW Murdock Rd & SW Sunset Blvd

01/30/2019



Movement	EBL	EBT	EBR	WBL	WBT	WBR	NBL	NBT	NBR	SBL	SBT	SBR
Lane Configurations												
Sign Control	Stop				Stop			Stop			Stop	
Traffic Volume (vph)	238	7	202	5	20	23	124	133	3	5	109	61
Future Volume (vph)	238	7	202	5	20	23	124	133	3	5	109	61
Peak Hour Factor	0.91	0.91	0.91	0.91	0.91	0.91	0.91	0.91	0.91	0.91	0.91	0.91
Hourly flow rate (vph)	262	8	222	5	22	25	136	146	3	5	120	67

Direction, Lane #	EB 1	EB 2	WB 1	NB 1	SB 1
Volume Total (vph)	262	230	52	285	192
Volume Left (vph)	262	0	5	136	5
Volume Right (vph)	0	222	25	3	67
Hadj (s)	0.55	-0.60	-0.20	0.20	-0.09
Departure Headway (s)	6.5	5.4	6.0	5.8	5.7
Degree Utilization, x	0.48	0.34	0.09	0.46	0.31
Capacity (veh/h)	528	642	520	580	585
Control Delay (s)	14.2	10.0	9.6	13.7	11.2
Approach Delay (s)	12.2		9.6	13.7	11.2
Approach LOS	B		A	B	B

Intersection Summary

Delay	12.3
Level of Service	B
Intersection Capacity Utilization	53.6%
ICU Level of Service	A
Analysis Period (min)	15

HCM Unsignalized Intersection Capacity Analysis  
 106: SW Pacific Hwy & SW Chapman Rd

01/30/2019

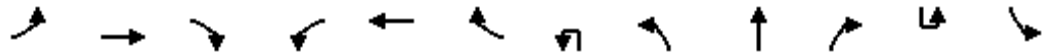

Movement	EBL	EBT	EBR	WBL	WBT	WBR	NBU	NBL	NBT	NBR	SBU	SBL
Lane Configurations		↔			↔			↔	↕			↔
Traffic Volume (veh/h)	27	3	2	37	3	39	4	8	1850	84	3	17
Future Volume (Veh/h)	27	3	2	37	3	39	4	8	1850	84	3	17
Sign Control		Stop			Stop				Free			
Grade		0%			0%				0%			
Peak Hour Factor	0.96	0.96	0.96	0.96	0.96	0.96	0.96	0.96	0.96	0.96	0.96	0.96
Hourly flow rate (vph)	28	3	2	39	3	41	0	8	1927	88	0	18
Pedestrians												
Lane Width (ft)												
Walking Speed (ft/s)												
Percent Blockage												
Right turn flare (veh)												
Median type									Raised			
Median storage (veh)									2			
Upstream signal (ft)												
pX, platoon unblocked							0.00				0.00	
vC, conflicting volume	2175	3184	558	2585	3156	1008	0	1133			0	2015
vC1, stage 1 conf vol	1153	1153		1987	1987							
vC2, stage 2 conf vol	1022	2031		598	1169							
vCu, unblocked vol	2175	3184	558	2585	3156	1008	0	1133			0	2015
tC, single (s)	7.7	6.5	6.9	7.6	6.5	7.2	0.0	4.1			0.0	4.1
tC, 2 stage (s)	6.7	5.5		6.6	5.5							
tF (s)	3.6	4.0	3.3	3.5	4.0	3.4	0.0	2.2			0.0	2.2
p0 queue free %	76	96	100	32	97	81	0	99			0	94
cM capacity (veh/h)	119	76	478	58	93	220	0	624			0	287

Direction, Lane #	EB 1	WB 1	NB 1	NB 2	NB 3	SB 1	SB 2	SB 3	SB 4
Volume Total	33	83	8	1285	730	18	558	558	16
Volume Left	28	39	8	0	0	18	0	0	0
Volume Right	2	41	0	0	88	0	0	0	16
cSH	118	93	624	1700	1700	287	1700	1700	1700
Volume to Capacity	0.28	0.89	0.01	0.76	0.43	0.06	0.33	0.33	0.01
Queue Length 95th (ft)	26	125	1	0	0	5	0	0	0
Control Delay (s)	46.7	147.1	10.8	0.0	0.0	18.4	0.0	0.0	0.0
Lane LOS	E	F	B			C			
Approach Delay (s)	46.7	147.1	0.0			0.3			
Approach LOS	E	F							

Intersection Summary		
Average Delay		4.3
Intersection Capacity Utilization	64.9%	ICU Level of Service C
Analysis Period (min)		15

HCM Unsignalized Intersection Capacity Analysis  
 106: SW Pacific Hwy & SW Chapman Rd

01/30/2019



Movement	SBT	SBR
Lane Configurations	↑↑	↑
Traffic Volume (veh/h)	1072	15
Future Volume (Veh/h)	1072	15
Sign Control	Free	
Grade	0%	
Peak Hour Factor	0.96	0.96
Hourly flow rate (vph)	1117	16
Pedestrians		
Lane Width (ft)		
Walking Speed (ft/s)		
Percent Blockage		
Right turn flare (veh)		
Median type	Raised	
Median storage veh)	2	
Upstream signal (ft)		
pX, platoon unblocked		
vC, conflicting volume		
vC1, stage 1 conf vol		
vC2, stage 2 conf vol		
vCu, unblocked vol		
tC, single (s)		
tC, 2 stage (s)		
tF (s)		
p0 queue free %		
cM capacity (veh/h)		
Direction, Lane #		

HCM Unsignalized Intersection Capacity Analysis  
 107: SW Old Hwy 99W & SW Brookman Rd

01/30/2019



Movement	EBL	EBT	EBR	WBL	WBT	WBR	NBL	NBT	NBR	SBL	SBT	SBR
Lane Configurations		↕			↕			↕			↕	
Traffic Volume (veh/h)	10	89	1	0	63	3	2	2	2	8	3	14
Future Volume (Veh/h)	10	89	1	0	63	3	2	2	2	8	3	14
Sign Control		Free			Free			Stop			Stop	
Grade		0%			2%			2%			-2%	
Peak Hour Factor	0.69	0.69	0.69	0.69	0.69	0.69	0.69	0.69	0.69	0.69	0.69	0.69
Hourly flow rate (vph)	14	129	1	0	91	4	3	3	3	12	4	20
Pedestrians												
Lane Width (ft)												
Walking Speed (ft/s)												
Percent Blockage												
Right turn flare (veh)												
Median type		None			None							
Median storage (veh)												
Upstream signal (ft)												
pX, platoon unblocked												
vC, conflicting volume	95			130			272	252	130	255	251	93
vC1, stage 1 conf vol												
vC2, stage 2 conf vol												
vCu, unblocked vol	95			130			272	252	130	255	251	93
tC, single (s)	4.1			4.1			7.6	7.0	6.2	7.1	6.5	6.4
tC, 2 stage (s)												
tF (s)	2.2			2.2			4.0	4.5	3.3	3.5	4.0	3.5
p0 queue free %	99			100			99	99	100	98	99	98
cM capacity (veh/h)	1512			1468			573	571	926	693	650	914
<b>Direction, Lane #</b>												
	EB 1	WB 1	NB 1	SB 1								
Volume Total	144	95	9	36								
Volume Left	14	0	3	12								
Volume Right	1	4	3	20								
cSH	1512	1468	656	794								
Volume to Capacity	0.01	0.00	0.01	0.05								
Queue Length 95th (ft)	1	0	1	4								
Control Delay (s)	0.8	0.0	10.6	9.8								
Lane LOS	A		B	A								
Approach Delay (s)	0.8	0.0	10.6	9.8								
Approach LOS			B	A								
<b>Intersection Summary</b>												
Average Delay			2.0									
Intersection Capacity Utilization			22.0%		ICU Level of Service				A			
Analysis Period (min)			15									

HCM Unsignalized Intersection Capacity Analysis  
 108: SW Middleton Rd & SW Brookman Rd

01/30/2019



Movement	EBL	EBT	EBR	WBL	WBT	WBR	NBL	NBT	NBR	SBL	SBT	SBR
Lane Configurations		↕			↕			↕			↕	
Traffic Volume (veh/h)	3	87	8	2	56	6	10	10	9	7	4	3
Future Volume (Veh/h)	3	87	8	2	56	6	10	10	9	7	4	3
Sign Control		Stop			Stop			Free			Free	
Grade		-1%			1%			-2%			0%	
Peak Hour Factor	0.72	0.72	0.72	0.72	0.72	0.72	0.72	0.72	0.72	0.72	0.72	0.72
Hourly flow rate (vph)	4	121	11	3	78	8	14	14	13	10	6	4
Pedestrians												
Lane Width (ft)												
Walking Speed (ft/s)												
Percent Blockage												
Right turn flare (veh)												
Median type								None			None	
Median storage (veh)												
Upstream signal (ft)												
pX, platoon unblocked												
vC, conflicting volume	124	83	8	148	78	20	10			27		
vC1, stage 1 conf vol												
vC2, stage 2 conf vol												
vCu, unblocked vol	124	83	8	148	78	20	10			27		
tC, single (s)	7.1	6.5	6.2	7.6	6.6	6.4	4.1			4.1		
tC, 2 stage (s)												
tF (s)	3.5	4.0	3.3	4.0	4.0	3.5	2.2			2.2		
p0 queue free %	99	85	99	100	90	99	99			99		
cM capacity (veh/h)	776	797	1080	625	794	1015	1623			1600		
<b>Direction, Lane #</b>	<b>EB 1</b>	<b>WB 1</b>	<b>NB 1</b>	<b>SB 1</b>								
Volume Total	136	89	41	20								
Volume Left	4	3	14	10								
Volume Right	11	8	13	4								
cSH	814	802	1623	1600								
Volume to Capacity	0.17	0.11	0.01	0.01								
Queue Length 95th (ft)	15	9	1	0								
Control Delay (s)	10.3	10.0	2.5	3.7								
Lane LOS	B	B	A	A								
Approach Delay (s)	10.3	10.0	2.5	3.7								
Approach LOS	B	B										
<b>Intersection Summary</b>												
Average Delay			8.6									
Intersection Capacity Utilization			16.3%		ICU Level of Service				A			
Analysis Period (min)			15									



HCM Unsignalized Intersection Capacity Analysis  
 109: SW Oberst Rd & SW Brookman Rd

01/30/2019



Movement	EBT	EBR	WBL	WBT	NBL	NBR
Lane Configurations	→			←	↔	↔
Traffic Volume (veh/h)	105	1	1	60	2	3
Future Volume (Veh/h)	105	1	1	60	2	3
Sign Control	Free			Free	Stop	
Grade	-3%			2%	1%	
Peak Hour Factor	0.68	0.68	0.68	0.68	0.68	0.68
Hourly flow rate (vph)	154	1	1	88	3	4
Pedestrians				1		
Lane Width (ft)				12.0		
Walking Speed (ft/s)				3.5		
Percent Blockage				0		
Right turn flare (veh)						
Median type	None			None		
Median storage (veh)						
Upstream signal (ft)						
pX, platoon unblocked						
vC, conflicting volume			155			156
vC1, stage 1 conf vol						
vC2, stage 2 conf vol						
vCu, unblocked vol			155			156
tC, single (s)			4.1			6.5
tC, 2 stage (s)						
tF (s)			2.2			3.6
p0 queue free %			100			100
cM capacity (veh/h)			1438			814

Direction, Lane #	EB 1	WB 1	NB 1
Volume Total	155	89	7
Volume Left	0	1	3
Volume Right	1	0	4
cSH	1700	1438	784
Volume to Capacity	0.09	0.00	0.01
Queue Length 95th (ft)	0	0	1
Control Delay (s)	0.0	0.1	9.6
Lane LOS	A		A
Approach Delay (s)	0.0	0.1	9.6
Approach LOS	A		

Intersection Summary			
Average Delay			0.3
Intersection Capacity Utilization	15.9%	ICU Level of Service	A
Analysis Period (min)			15

HCM Unsignalized Intersection Capacity Analysis  
 110: SW Ladd Hill Rd & SW Brookman Rd

01/30/2019



Movement	EBL	EBR	NBL	NBT	SBT	SBR
Lane Configurations						
Traffic Volume (veh/h)	92	24	18	106	40	38
Future Volume (Veh/h)	92	24	18	106	40	38
Sign Control	Stop			Free	Free	
Grade	2%			-1%	0%	
Peak Hour Factor	0.70	0.70	0.70	0.70	0.70	0.70
Hourly flow rate (vph)	131	34	26	151	57	54
Pedestrians					1	
Lane Width (ft)					12.0	
Walking Speed (ft/s)					3.5	
Percent Blockage					0	
Right turn flare (veh)						
Median type				None	None	
Median storage (veh)						
Upstream signal (ft)						
pX, platoon unblocked						
vC, conflicting volume	288	84	111			
vC1, stage 1 conf vol						
vC2, stage 2 conf vol						
vCu, unblocked vol	288	84	111			
tC, single (s)	6.4	6.3	4.3			
tC, 2 stage (s)						
tF (s)	3.5	3.4	2.4			
p0 queue free %	81	96	98			
cM capacity (veh/h)	688	959	1390			
<b>Direction, Lane #</b>	<b>EB 1</b>	<b>NB 1</b>	<b>SB 1</b>			
Volume Total	165	177	111			
Volume Left	131	26	0			
Volume Right	34	0	54			
cSH	731	1390	1700			
Volume to Capacity	0.23	0.02	0.07			
Queue Length 95th (ft)	22	1	0			
Control Delay (s)	11.4	1.3	0.0			
Lane LOS	B	A				
Approach Delay (s)	11.4	1.3	0.0			
Approach LOS	B					
<b>Intersection Summary</b>						
Average Delay			4.6			
Intersection Capacity Utilization			26.5%	ICU Level of Service	A	
Analysis Period (min)			15			

HCM Signalized Intersection Capacity Analysis  
 101: SW Pacific Hwy & SW Elwert Rd/SW Sunset Blvd

01/30/2019



Movement	EBL	EBT	EBR	WBL	WBT	WBR	NBL	NBT	NBR	SBL	SBT	SBR
Lane Configurations		↖	↗		↖	↗	↖	↕	↗	↖	↕	↗
Traffic Volume (vph)	13	122	294	127	106	135	219	1012	125	258	1669	13
Future Volume (vph)	13	122	294	127	106	135	219	1012	125	258	1669	13
Ideal Flow (vphpl)	1900	1900	1900	1900	1900	1900	1900	1900	1900	1900	1900	1900
Grade (%)		0%			0%			-1%			2%	
Total Lost time (s)		6.0	6.0		6.0	6.0	5.0	6.0	6.0	5.0	6.0	6.0
Lane Util. Factor		1.00	1.00		1.00	1.00	1.00	0.95	1.00	0.97	0.95	1.00
Frbp, ped/bikes		1.00	1.00		1.00	0.98	1.00	1.00	0.99	1.00	1.00	1.00
Flpb, ped/bikes		1.00	1.00		1.00	1.00	1.00	1.00	1.00	1.00	1.00	1.00
Frt		1.00	0.85		1.00	0.85	1.00	1.00	0.85	1.00	1.00	0.85
Flt Protected		1.00	1.00		0.97	1.00	0.95	1.00	1.00	0.95	1.00	1.00
Satd. Flow (prot)		1876	1583		1775	1558	1796	3489	1587	3467	3504	1599
Flt Permitted		0.94	1.00		0.66	1.00	0.95	1.00	1.00	0.95	1.00	1.00
Satd. Flow (perm)		1765	1583		1195	1558	1796	3489	1587	3467	3504	1599
Peak-hour factor, PHF	0.94	0.94	0.94	0.94	0.94	0.94	0.94	0.94	0.94	0.94	0.94	0.94
Adj. Flow (vph)	14	130	313	135	113	144	233	1077	133	274	1776	14
RTOR Reduction (vph)	0	0	235	0	0	85	0	0	32	0	0	7
Lane Group Flow (vph)	0	144	78	0	248	59	233	1077	101	274	1776	7
Confl. Peds. (#/hr)	3					3						
Confl. Bikes (#/hr)									1			
Heavy Vehicles (%)	8%	0%	2%	6%	2%	2%	1%	4%	1%	0%	2%	0%
Turn Type	Perm	NA	Perm	Perm	NA	Perm	Prot	NA	Perm	Prot	NA	Perm
Protected Phases		4			8		5	2		1		6
Permitted Phases	4		4	8		8			2			6
Actuated Green, G (s)		35.2	35.2		35.2	35.2	24.6	86.5	86.5	18.2	80.1	80.1
Effective Green, g (s)		35.2	35.2		35.2	35.2	24.6	86.5	86.5	18.2	80.1	80.1
Actuated g/C Ratio		0.22	0.22		0.22	0.22	0.16	0.55	0.55	0.12	0.51	0.51
Clearance Time (s)		6.0	6.0		6.0	6.0	5.0	6.0	6.0	5.0	6.0	6.0
Vehicle Extension (s)		3.0	3.0		3.0	3.0	3.0	5.4	5.4	3.5	5.4	5.4
Lane Grp Cap (vph)		395	355		268	349	281	1923	874	402	1788	816
v/s Ratio Prot							c0.13	0.31		0.08	c0.51	
v/s Ratio Perm		0.08	0.05		c0.21	0.04			0.06			0.00
v/c Ratio		0.36	0.22		0.93	0.17	0.83	0.56	0.12	0.68	0.99	0.01
Uniform Delay, d1		51.4	49.6		59.6	49.1	64.1	22.8	16.9	66.6	38.1	18.9
Progression Factor		1.00	1.00		1.00	1.00	1.00	1.00	1.00	1.00	1.00	1.00
Incremental Delay, d2		0.6	0.3		35.4	0.2	17.9	0.7	0.1	4.9	19.7	0.0
Delay (s)		52.0	50.0		94.9	49.3	82.1	23.5	17.0	71.5	57.8	18.9
Level of Service		D	D		F	D	F	C	B	E	E	B
Approach Delay (s)		50.6			78.2			32.4			59.4	
Approach LOS		D			E			C			E	

Intersection Summary

HCM 2000 Control Delay	51.2	HCM 2000 Level of Service	D
HCM 2000 Volume to Capacity ratio	0.95		
Actuated Cycle Length (s)	156.9	Sum of lost time (s)	17.0
Intersection Capacity Utilization	98.9%	ICU Level of Service	F
Analysis Period (min)	15		

c Critical Lane Group

# HCM Unsignalized Intersection Capacity Analysis

## 102: SW Woodhaven Dr & SW Sunset Blvd

01/30/2019



Movement	EBL	EBT	EBR	WBL	WBT	WBR	NBL	NBT	NBR	SBL	SBT	SBR	
Lane Configurations													
Traffic Volume (veh/h)	101	344	24	5	370	68	10	0	1	34	1	52	
Future Volume (Veh/h)	101	344	24	5	370	68	10	0	1	34	1	52	
Sign Control		Free			Free			Stop			Stop		
Grade		-1%			1%			-2%			0%		
Peak Hour Factor	0.92	0.92	0.92	0.92	0.92	0.92	0.92	0.92	0.92	0.92	0.92	0.92	
Hourly flow rate (vph)	110	374	26	5	402	74	11	0	1	37	1	57	
Pedestrians													
Lane Width (ft)													
Walking Speed (ft/s)													
Percent Blockage													
Right turn flare (veh)													
Median type	None					None							
Median storage (veh)													
Upstream signal (ft)	648												
pX, platoon unblocked				0.98			0.98			0.98			
vC, conflicting volume	476			400			1064			1080			
vC1, stage 1 conf vol													
vC2, stage 2 conf vol													
vCu, unblocked vol	476			380			1056			1072			
tC, single (s)	4.1			4.1			7.1			6.5			
tC, 2 stage (s)													
tF (s)	2.2			2.2			3.5			4.0			
p0 queue free %	90			100			93			100			
cM capacity (veh/h)	1091			1168			168			196			
Direction, Lane #													
	EB 1	EB 2	EB 3	WB 1	WB 2	NB 1	SB 1						
Volume Total	110	374	26	5	476	12	95						
Volume Left	110	0	0	5	0	11	37						
Volume Right	0	0	26	0	74	1	57						
cSH	1091	1700	1700	1168	1700	179	326						
Volume to Capacity	0.10	0.22	0.02	0.00	0.28	0.07	0.29						
Queue Length 95th (ft)	8	0	0	0	0	5	30						
Control Delay (s)	8.7	0.0	0.0	8.1	0.0	26.5	20.5						
Lane LOS	A			A			D			C			
Approach Delay (s)	1.9			0.1			26.5			20.5			
Approach LOS							D			C			
Intersection Summary													
Average Delay	3.0												
Intersection Capacity Utilization	43.9%			ICU Level of Service					A				
Analysis Period (min)	15												

# HCM Unsignalized Intersection Capacity Analysis

## 103: SW Timbrel Ln & SW Sunset Blvd

01/30/2019























Movement	EBT	EBR	WBL	WBT	NBL	NBR
Lane Configurations	↻		↻	↻	↻	
Traffic Volume (veh/h)	276	103	59	360	83	35
Future Volume (Veh/h)	276	103	59	360	83	35
Sign Control	Free			Free	Stop	
Grade	-1%			1%	0%	
Peak Hour Factor	0.91	0.91	0.91	0.91	0.91	0.91
Hourly flow rate (vph)	303	113	65	396	91	38
Pedestrians				1		
Lane Width (ft)				12.0		
Walking Speed (ft/s)				3.5		
Percent Blockage				0		
Right turn flare (veh)						
Median type	None			None		
Median storage (veh)						
Upstream signal (ft)	1264					
pX, platoon unblocked						
vC, conflicting volume			416			886 360
vC1, stage 1 conf vol						
vC2, stage 2 conf vol						
vCu, unblocked vol			416			886 360
tC, single (s)			4.1			6.4 6.2
tC, 2 stage (s)						
tF (s)			2.2			3.5 3.3
p0 queue free %			94			69 94
cM capacity (veh/h)			1138			297 681

Direction, Lane #	EB 1	WB 1	WB 2	NB 1
Volume Total	416	65	396	129
Volume Left	0	65	0	91
Volume Right	113	0	0	38
cSH	1700	1138	1700	356
Volume to Capacity	0.24	0.06	0.23	0.36
Queue Length 95th (ft)	0	5	0	40
Control Delay (s)	0.0	8.4	0.0	20.7
Lane LOS	A		C	
Approach Delay (s)	0.0	1.2	20.7	
Approach LOS	C			

Intersection Summary			
Average Delay	3.2		
Intersection Capacity Utilization	41.1%	ICU Level of Service	A
Analysis Period (min)	15		

HCM Unsignalized Intersection Capacity Analysis  
 104: SW Main St/SW Ladd Hill Rd & SW Sunset Blvd

01/30/2019

												
Movement	EBL	EBT	EBR	WBL	WBT	WBR	NBL	NBT	NBR	SBL	SBT	SBR
Lane Configurations												
Sign Control	Stop			Stop			Stop			Stop		
Traffic Volume (vph)	25	112	124	32	84	49	91	213	27	65	347	39
Future Volume (vph)	25	112	124	32	84	49	91	213	27	65	347	39
Peak Hour Factor	0.89	0.89	0.89	0.89	0.89	0.89	0.89	0.89	0.89	0.89	0.89	0.89
Hourly flow rate (vph)	28	126	139	36	94	55	102	239	30	73	390	44
Direction, Lane #	EB 1	EB 2	WB 1	WB 2	NB 1	NB 2	SB 1	SB 2				
Volume Total (vph)	28	265	36	149	102	269	73	434				
Volume Left (vph)	28	0	36	0	102	0	73	0				
Volume Right (vph)	0	139	0	55	0	30	0	44				
Hadj (s)	0.50	-0.34	0.55	-0.25	0.50	-0.03	0.53	-0.05				
Departure Headway (s)	7.9	7.0	8.2	7.4	7.5	6.9	7.3	6.7				
Degree Utilization, x	0.06	0.52	0.08	0.31	0.21	0.52	0.15	0.81				
Capacity (veh/h)	429	478	405	449	460	489	475	524				
Control Delay (s)	10.2	16.2	10.7	12.4	11.3	16.0	10.3	30.8				
Approach Delay (s)	15.6		12.1		14.7		27.9					
Approach LOS	C		B		B		D					
Intersection Summary												
Delay			19.5									
Level of Service			C									
Intersection Capacity Utilization			56.1%		ICU Level of Service		B					
Analysis Period (min)			15									

HCM Unsignalized Intersection Capacity Analysis  
 105: SW Baker Rd/SW Murdock Rd & SW Sunset Blvd

01/30/2019



Movement	EBL	EBT	EBR	WBL	WBT	WBR	NBL	NBT	NBR	SBL	SBT	SBR
Lane Configurations												
Sign Control	Stop				Stop			Stop			Stop	
Traffic Volume (vph)	92	12	154	1	19	15	293	135	6	30	141	251
Future Volume (vph)	92	12	154	1	19	15	293	135	6	30	141	251
Peak Hour Factor	0.90	0.90	0.90	0.90	0.90	0.90	0.90	0.90	0.90	0.90	0.90	0.90
Hourly flow rate (vph)	102	13	171	1	21	17	326	150	7	33	157	279

Direction, Lane #	EB 1	EB 2	WB 1	NB 1	SB 1
Volume Total (vph)	102	184	39	483	469
Volume Left (vph)	102	0	1	326	33
Volume Right (vph)	0	171	17	7	279
Hadj (s)	0.50	-0.57	-0.21	0.15	-0.31
Departure Headway (s)	7.7	6.6	7.3	5.9	5.5
Degree Utilization, x	0.22	0.34	0.08	0.79	0.72
Capacity (veh/h)	430	488	422	597	629
Control Delay (s)	11.6	11.7	10.9	27.4	21.1
Approach Delay (s)	11.7		10.9	27.4	21.1
Approach LOS	B		B	D	C

Intersection Summary

Delay	21.1
Level of Service	C
Intersection Capacity Utilization	70.0%
ICU Level of Service	C
Analysis Period (min)	15

HCM Unsignalized Intersection Capacity Analysis  
 106: SW Pacific Hwy & SW Chapman Rd

01/30/2019



Movement	EBL	EBT	EBR	WBL	WBT	WBR	NBU	NBL	NBT	NBR	SBU	SBL
Lane Configurations		↕			↕			↕	↕			↕
Traffic Volume (veh/h)	19	7	11	38	5	27	1	8	1325	43	2	22
Future Volume (Veh/h)	19	7	11	38	5	27	1	8	1325	43	2	22
Sign Control		Stop			Stop				Free			
Grade		0%			0%				0%			
Peak Hour Factor	0.96	0.96	0.96	0.96	0.96	0.96	0.96	0.96	0.96	0.96	0.96	0.96
Hourly flow rate (vph)	20	7	11	40	5	28	0	8	1380	45	0	23
Pedestrians												
Lane Width (ft)												
Walking Speed (ft/s)												
Percent Blockage												
Right turn flare (veh)												
Median type									Raised			
Median storage (veh)									2			
Upstream signal (ft)												
pX, platoon unblocked							0.00				0.00	
vC, conflicting volume	2898	3603	1058	2537	3622	712	0	2158			0	1425
vC1, stage 1 conf vol	2162	2162		1418	1418							
vC2, stage 2 conf vol	736	1441		1118	2204							
vCu, unblocked vol	2898	3603	1058	2537	3622	712	0	2158			0	1425
tC, single (s)	7.6	6.5	6.9	7.6	6.5	6.9	0.0	4.1			0.0	4.1
tC, 2 stage (s)	6.6	5.5		6.6	5.5							
tF (s)	3.5	4.0	3.3	3.5	4.0	3.3	0.0	2.2			0.0	2.2
p0 queue free %	53	90	95	61	92	93	0	97			0	95
cM capacity (veh/h)	43	71	224	103	64	379	0	252			0	484

Direction, Lane #	EB 1	WB 1	NB 1	NB 2	NB 3	SB 1	SB 2	SB 3	SB 4
Volume Total	38	73	8	920	505	23	1058	1058	42
Volume Left	20	40	8	0	0	23	0	0	0
Volume Right	11	28	0	0	45	0	0	0	42
cSH	62	135	252	1700	1700	484	1700	1700	1700
Volume to Capacity	0.62	0.54	0.03	0.54	0.30	0.05	0.62	0.62	0.02
Queue Length 95th (ft)	64	66	2	0	0	4	0	0	0
Control Delay (s)	130.4	59.2	19.7	0.0	0.0	12.8	0.0	0.0	0.0
Lane LOS	F	F	C			B			
Approach Delay (s)	130.4	59.2	0.1			0.1			
Approach LOS	F	F							

Intersection Summary		
Average Delay		2.6
Intersection Capacity Utilization	67.9%	ICU Level of Service
Analysis Period (min)	15	C



HCM Unsignalized Intersection Capacity Analysis  
 106: SW Pacific Hwy & SW Chapman Rd

01/30/2019



Movement	SBT	SBR
Lane Configurations	↑↑	↑
Traffic Volume (veh/h)	2031	40
Future Volume (Veh/h)	2031	40
Sign Control	Free	
Grade	0%	
Peak Hour Factor	0.96	0.96
Hourly flow rate (vph)	2116	42
Pedestrians		
Lane Width (ft)		
Walking Speed (ft/s)		
Percent Blockage		
Right turn flare (veh)		
Median type	Raised	
Median storage (veh)	2	
Upstream signal (ft)		
pX, platoon unblocked		
vC, conflicting volume		
vC1, stage 1 conf vol		
vC2, stage 2 conf vol		
vCu, unblocked vol		
tC, single (s)		
tC, 2 stage (s)		
tF (s)		
p0 queue free %		
cM capacity (veh/h)		
Direction, Lane #		

HCM Unsignalized Intersection Capacity Analysis  
 107: SW Old Hwy 99W & SW Brookman Rd

01/30/2019



Movement	EBL	EBT	EBR	WBL	WBT	WBR	NBL	NBT	NBR	SBL	SBT	SBR
Lane Configurations		↕			↕			↕			↕	
Traffic Volume (veh/h)	9	56	1	1	65	2	1	1	2	1	1	1
Future Volume (Veh/h)	9	56	1	1	65	2	1	1	2	1	1	1
Sign Control		Free			Free			Stop			Stop	
Grade		0%			2%			2%			-2%	
Peak Hour Factor	0.82	0.82	0.82	0.82	0.82	0.82	0.82	0.82	0.82	0.82	0.82	0.82
Hourly flow rate (vph)	11	68	1	1	79	2	1	1	2	1	1	1
Pedestrians												
Lane Width (ft)												
Walking Speed (ft/s)												
Percent Blockage												
Right turn flare (veh)												
Median type		None			None							
Median storage (veh)												
Upstream signal (ft)												
pX, platoon unblocked												
vC, conflicting volume	81			69			174	174	68	175	173	80
vC1, stage 1 conf vol												
vC2, stage 2 conf vol												
vCu, unblocked vol	81			69			174	174	68	175	173	80
tC, single (s)	4.1			4.1			7.1	6.5	6.2	7.1	6.5	6.2
tC, 2 stage (s)												
tF (s)	2.2			2.2			3.5	4.0	3.3	3.5	4.0	3.3
p0 queue free %	99			100			100	100	100	100	100	100
cM capacity (veh/h)	1529			1545			787	718	1000	785	718	986
<b>Direction, Lane #</b>	<b>EB 1</b>	<b>WB 1</b>	<b>NB 1</b>	<b>SB 1</b>								
Volume Total	80	82	4	3								
Volume Left	11	1	1	1								
Volume Right	1	2	2	1								
cSH	1529	1545	858	815								
Volume to Capacity	0.01	0.00	0.00	0.00								
Queue Length 95th (ft)	1	0	0	0								
Control Delay (s)	1.1	0.1	9.2	9.4								
Lane LOS	A	A	A	A								
Approach Delay (s)	1.1	0.1	9.2	9.4								
Approach LOS			A	A								
<b>Intersection Summary</b>												
Average Delay			0.9									
Intersection Capacity Utilization			18.5%		ICU Level of Service				A			
Analysis Period (min)			15									

# HCM Unsignalized Intersection Capacity Analysis

## 108: SW Middleton Rd & SW Brookman Rd

01/30/2019



Movement	EBL	EBT	EBR	WBL	WBT	WBR	NBL	NBT	NBR	SBL	SBT	SBR
Lane Configurations		↕			↕			↕			↕	
Traffic Volume (veh/h)	9	40	14	11	47	3	13	6	8	2	9	4
Future Volume (Veh/h)	9	40	14	11	47	3	13	6	8	2	9	4
Sign Control		Stop			Stop			Free			Free	
Grade		-1%			1%			-2%			0%	
Peak Hour Factor	0.74	0.74	0.74	0.74	0.74	0.74	0.74	0.74	0.74	0.74	0.74	0.74
Hourly flow rate (vph)	12	54	19	15	64	4	18	8	11	3	12	5
Pedestrians		1			1						1	
Lane Width (ft)		12.0			12.0						12.0	
Walking Speed (ft/s)		3.5			3.5						3.5	
Percent Blockage		0			0						0	
Right turn flare (veh)												
Median type								None			None	
Median storage (veh)												
Upstream signal (ft)												
pX, platoon unblocked												
vC, conflicting volume	108	78	16	117	74	16	18			20		
vC1, stage 1 conf vol												
vC2, stage 2 conf vol												
vCu, unblocked vol	108	78	16	117	74	16	18			20		
tC, single (s)	7.1	6.5	6.2	7.2	6.5	6.2	4.2			4.1		
tC, 2 stage (s)												
tF (s)	3.5	4.0	3.3	3.6	4.0	3.3	2.3			2.2		
p0 queue free %	99	93	98	98	92	100	99			100		
cM capacity (veh/h)	808	804	1069	775	807	1068	1517			1608		
<b>Direction, Lane #</b>	<b>EB 1</b>	<b>WB 1</b>	<b>NB 1</b>	<b>SB 1</b>								
Volume Total	85	83	37	20								
Volume Left	12	15	18	3								
Volume Right	19	4	11	5								
cSH	852	811	1517	1608								
Volume to Capacity	0.10	0.10	0.01	0.00								
Queue Length 95th (ft)	8	9	1	0								
Control Delay (s)	9.7	9.9	3.6	1.1								
Lane LOS	A	A	A	A								
Approach Delay (s)	9.7	9.9	3.6	1.1								
Approach LOS	A	A										
<b>Intersection Summary</b>												
Average Delay			8.0									
Intersection Capacity Utilization			16.1%		ICU Level of Service				A			
Analysis Period (min)			15									

HCM Unsignalized Intersection Capacity Analysis  
 109: SW Oberst Rd & SW Brookman Rd

01/30/2019

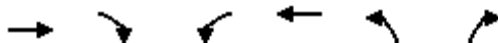

Movement	EBT	EBR	WBL	WBT	NBL	NBR
Lane Configurations	→			←	←	←
Traffic Volume (veh/h)	48	0	4	63	4	4
Future Volume (Veh/h)	48	0	4	63	4	4
Sign Control	Free			Free	Stop	
Grade	-3%			2%	1%	
Peak Hour Factor	0.69	0.69	0.69	0.69	0.69	0.69
Hourly flow rate (vph)	70	0	6	91	6	6
Pedestrians						
Lane Width (ft)						
Walking Speed (ft/s)						
Percent Blockage						
Right turn flare (veh)						
Median type	None			None		
Median storage (veh)						
Upstream signal (ft)						
pX, platoon unblocked						
vC, conflicting volume			70		173	70
vC1, stage 1 conf vol						
vC2, stage 2 conf vol						
vCu, unblocked vol			70		173	70
tC, single (s)			4.1		6.7	6.5
tC, 2 stage (s)						
tF (s)			2.2		3.7	3.5
p0 queue free %			100		99	99
cM capacity (veh/h)			1544		764	932

Direction, Lane #	EB 1	WB 1	NB 1
Volume Total	70	97	12
Volume Left	0	6	6
Volume Right	0	0	6
cSH	1700	1544	840
Volume to Capacity	0.04	0.00	0.01
Queue Length 95th (ft)	0	0	1
Control Delay (s)	0.0	0.5	9.4
Lane LOS		A	A
Approach Delay (s)	0.0	0.5	9.4
Approach LOS			A

Intersection Summary			
Average Delay		0.9	
Intersection Capacity Utilization	16.6%	ICU Level of Service	A
Analysis Period (min)	15		

# HCM Unsignalized Intersection Capacity Analysis

## 110: SW Ladd Hill Rd & SW Brookman Rd

01/30/2019



Movement	EBL	EBR	NBL	NBT	SBT	SBR
Lane Configurations						
Traffic Volume (veh/h)	33	15	9	81	90	52
Future Volume (Veh/h)	33	15	9	81	90	52
Sign Control	Stop			Free	Free	
Grade	2%			-1%	0%	
Peak Hour Factor	0.78	0.78	0.78	0.78	0.78	0.78
Hourly flow rate (vph)	42	19	12	104	115	67
<b>Pedestrians</b>						
Lane Width (ft)						
Walking Speed (ft/s)						
Percent Blockage						
Right turn flare (veh)						
Median type				None	None	
Median storage (veh)						
Upstream signal (ft)						
pX, platoon unblocked						
vC, conflicting volume	276	148	182			
vC1, stage 1 conf vol						
vC2, stage 2 conf vol						
vCu, unblocked vol	276	148	182			
tC, single (s)	6.4	6.3	4.1			
tC, 2 stage (s)						
tF (s)	3.5	3.4	2.2			
p0 queue free %	94	98	99			
cM capacity (veh/h)	705	885	1405			
<b>Direction, Lane #</b>	<b>EB 1</b>	<b>NB 1</b>	<b>SB 1</b>			
Volume Total	61	116	182			
Volume Left	42	12	0			
Volume Right	19	0	67			
cSH	753	1405	1700			
Volume to Capacity	0.08	0.01	0.11			
Queue Length 95th (ft)	7	1	0			
Control Delay (s)	10.2	0.8	0.0			
Lane LOS	B	A				
Approach Delay (s)	10.2	0.8	0.0			
Approach LOS	B					
<b>Intersection Summary</b>						
Average Delay			2.0			
Intersection Capacity Utilization			21.8%	ICU Level of Service	A	
Analysis Period (min)			15			

## Appendix E Queueing Summary

Appendix E. 95th Percentile Queues

ID	Intersection	Existing				Year 2020 Background				Year 2020 Total Traffic			
		Movement	Storage (ft)	Weekday AM	Weekday PM	Movement	Storage (ft)	Weekday AM	Weekday PM	Movement	Storage (ft)	Weekday AM	Weekday PM
1	Highway 99W/SW Elwert Road-SW Sunset Boulevard	EBL/T	85 <sup>1</sup>	148	203	EBL	85 <sup>1</sup>	287	98	EBL	85 <sup>1</sup>	287	98
		EBR	85 <sup>1</sup>	63	97	EBT/R	85 <sup>1</sup>	256	260	EBT/R	85 <sup>1</sup>	256	258
		WBL/T	600 <sup>1</sup>	351	438	WBL	230 <sup>4</sup>	227	315	WBL	600 <sup>1</sup>	227	312
		WBR	140	138	95	WBT/R	600 <sup>1</sup>	385	123	WBT/R	140	385	121
		NBL	320	295	341	NBL	320	247	250	NBL	320	257	250
		NBR	150	59	69	NBR	150	57	78	NBR	150	57	787
		SBL	210	90	194	SBL	210	110	236	SBL	210	112	235
		SBR	300	0	0	SBR	300	51	4	SBR	300	51	4
2	SW Woodhaven Drive/SW Sunset Boulevard	EBL	90	6	8	EBL	90	7	11	EBL	90	7	11
		EBR	150	0	0	EBR	150	0	0	EBR	150	0	0
		WBL	125	1	0	WBL	125	1	0	WBL	125	1	0
		WBT/R	675 <sup>1</sup>	0	0	WBT/R	675 <sup>1</sup>	0	0	WBT/R	675 <sup>1</sup>	0	0
		NBL/T/R	190 <sup>1</sup>	26	5	NBL/T/R	190 <sup>1</sup>	108	9	NBL/T/R	190 <sup>1</sup>	109	9
		SBL/T/R	460 <sup>1</sup>	96	30	SBL/T/R	460 <sup>1</sup>	344	44	SBL/T/R	460 <sup>1</sup>	344	46
3	SW Timbrel Lane/SW Sunset Boulevard	EBT/R	675 <sup>1</sup>	0	0	EBT/R	675 <sup>1</sup>	0	0	EBT/R	675 <sup>1</sup>	0	0
		WBL	115	6	5	WBL	115	7	5	WBL	115	7	5
		NBL/R	215 <sup>1</sup>	161	40	NBL/R	215 <sup>1</sup>	384	55	NBL/R	215 <sup>1</sup>	373	57
4	SW Ladd Hill Rd.-SW Main St./SW Sunset Boulevard <sup>2</sup>	EBL	95	23	5	EBL	95	28	5	EBL	95	28	5
		EBT/R	700 <sup>1</sup>	80	80	EBT/R	700 <sup>1</sup>	173	118	EBT/R	700 <sup>1</sup>	180	120
		WBL	100	5	8	WBL	100	8	8	WBL	100	8	13
		WBT/R	740 <sup>1</sup>	53	35	WBT/R	740 <sup>1</sup>	125	48	WBT/R	740 <sup>1</sup>	130	50
		NBL	100	15	20	NBL	100	23	25	NBL	100	23	25
		NBT/R	470 <sup>1</sup>	48	80	NBT/R	470 <sup>1</sup>	63	108	NBT/R	470 <sup>1</sup>	78	123
		SBL	150	5	13	SBL	150	8	15	SBL	150	8	15
		SBT/R	170 <sup>1</sup>	30	215	SBT/R	170 <sup>1</sup>	38	308	SBT/R	170 <sup>1</sup>	40	340
5	SW Baker Road-SW Murdock Road/SW Sunset Boulevard <sup>2</sup>	EBL	95	65	20	EBL	95	88	25	EBL	95	95	28
		EBT/R	880 <sup>1</sup>	40	38	EBT/R	880 <sup>1</sup>	50	43	EBT/R	880 <sup>1</sup>	53	48
		WBL/T/R	700 <sup>1</sup>	8	8	WBL/T/R	700 <sup>1</sup>	10	10	WBL/T/R	700 <sup>1</sup>	10	10
		NBL/T/R	390 <sup>1</sup>	63	188	NBL/T/R	390 <sup>1</sup>	78	258	NBL/T/R	390 <sup>1</sup>	80	280
		SBL/T/R	540 <sup>1</sup>	35	145	SBL/T/R	540 <sup>1</sup>	53	205	SBL/T/R	540 <sup>1</sup>	53	225
6	Highway 99W/SW Brookman Road-SW Chapman Road	EBL/T/R	1,000 <sup>1</sup>	26	64	EBL/T/R	1,000 <sup>1</sup>	37	76	EBL/T/R	1,000 <sup>1</sup>	62	91
		WBL/T/R	520 <sup>1</sup>	125	66	WBL/T/R	520 <sup>1</sup>	164	79	WBL/T/R	520 <sup>1</sup>	273	130
		NBL/U	260	1	2	NBL/U	260	1	3	NBL/U	260	1	3
		NBT/R	>1,000 <sup>1</sup>	0	0	NBT/R	>1,000 <sup>1</sup>	0	0	NBT/R	>1,000 <sup>1</sup>	0	0
		SBL/U	260	5	4	SBL/U	260	8	4	SBL/U	260	13	13
		SBR	255	0	0	SBR	255	0	0	SBR	255	0	0
7	Old Highway 99 W/SW Brookman Road	EBL/T/R	520 <sup>1</sup>	1	1	EBL/T/R	520 <sup>1</sup>	1	1	EBL/T/R	520 <sup>1</sup>	1	1
		WBL/T/R	220 <sup>3</sup>	0	0	WBL/T/R	220 <sup>3</sup>	0	0	WBL/T/R	220 <sup>3</sup>	0	0
		NBL/T/R	>1,000 <sup>1</sup>	1	0	NBL/T/R	>1,000 <sup>1</sup>	1	0	NBL/T/R	>1,000 <sup>1</sup>	1	0
		SBL/T/R	>1,000 <sup>1</sup>	4	0	SBL/T/R	>1,000 <sup>1</sup>	4	0	SBL/T/R	>1,000 <sup>1</sup>	4	0

ID	Intersection	Existing				Year 2020 Background				Year 2020 Total Traffic			
		Movement	Storage (ft)	Weekday AM	Weekday PM	Movement	Storage (ft)	Weekday AM	Weekday PM	Movement	Storage (ft)	Weekday AM	Weekday PM
8	SW Middleton Road/SW Brookman Road	EBL/T/R	>1,000 <sup>3</sup>	15	8	EBL/T/R	>1,000 <sup>3</sup>	18	9	EBL/T/R	>1,000 <sup>3</sup>	22	18
		WBL/T/R	>1,000 <sup>1</sup>	9	9	WBL/T/R	>1,000 <sup>1</sup>	10	9	WBL/T/R	>1,000 <sup>1</sup>	20	15
		NBL/T/R	400 <sup>1</sup>	1	1	NBL/T/R	400 <sup>1</sup>	1	1	NBL/T/R	400 <sup>1</sup>	1	1
		SBL/T/R	690 <sup>3</sup>	0	0	SBL/T/R	690 <sup>3</sup>	0	0	SBL/T/R	690 <sup>3</sup>	1	0
9	SW Oberst Road-Future Site Access/SW Brookman Road	EBT/R	890 <sup>1</sup>	0	0	EBT/R	890 <sup>1</sup>	0	0	EBL/T/R	890 <sup>1</sup>	1	5
		WBL/T	100 <sup>1</sup>	0	0	WBL/T	100 <sup>1</sup>	0	0	WBL/T/R	100 <sup>1</sup>	0	0
		NBL/R	>1,000 <sup>1</sup>	1	1	NBL/R	>1,000 <sup>1</sup>	1	1	NBL/T/R	>1,000 <sup>1</sup>	1	1
											SBL/T/R	250 <sup>1</sup>	14
10	SW Ladd Hill Road/SW Brookman Road	EBL/R	>1,000 <sup>1</sup>	22	7	EBL/R	>1,000 <sup>1</sup>	24	7	EBL/R	>1,000 <sup>1</sup>	34	11
		NBL/T	>1,000 <sup>1</sup>	1	1	NBL/T	>1,000 <sup>1</sup>	1	1	NBL/T	>1,000 <sup>1</sup>	2	1
		SBT/R	820 <sup>1</sup>	0	0	SBT/R	820 <sup>1</sup>	0	0	SBT/R	820 <sup>1</sup>	0	0

<sup>1</sup> Distance to adjacent intersection

<sup>2</sup> Queues were recorded from the HCM 2010 AWSC methodology, as implemented by Synchro

<sup>3</sup> Distance to railroad crossing

<sup>4</sup> Based on conceptual drawing provided by the City of Sherwood

Intersections 7, 8, 9 and 10 are not included as they do not have exclusive turn lanes

**Bold** and grey shading indicates 95<sup>th</sup> percentile queue exceeds available storage

Yellow shading indicates change in lane configuration



Queues

101: SW Pacific Hwy & SW Elwert Rd/SW Sunset Blvd

01/30/2019



Lane Group	EBT	EBR	WBT	WBR	NBL	NBT	NBR	SBL	SBT	SBR
Lane Group Flow (vph)	131	235	295	237	258	1663	112	135	806	14
v/c Ratio	0.29	0.39	0.74	0.44	0.79	0.94	0.14	0.49	0.60	0.02
Control Delay	39.4	6.5	55.0	17.3	67.3	41.7	9.7	61.7	32.8	0.1
Queue Delay	0.0	0.0	0.0	0.0	0.0	0.0	0.0	0.0	0.0	0.0
Total Delay	39.4	6.5	55.0	17.3	67.3	41.7	9.7	61.7	32.8	0.1
Queue Length 50th (ft)	86	0	223	56	207	664	24	56	272	0
Queue Length 95th (ft)	148	63	#351	138	295	#882	59	90	369	0
Internal Link Dist (ft)	263		568			888			476	
Turn Bay Length (ft)				140	320		150	210		300
Base Capacity (vph)	455	603	401	533	412	2176	994	744	2045	869
Starvation Cap Reductn	0	0	0	0	0	0	0	0	0	0
Spillback Cap Reductn	0	0	0	0	0	0	0	0	0	0
Storage Cap Reductn	0	0	0	0	0	0	0	0	0	0
Reduced v/c Ratio	0.29	0.39	0.74	0.44	0.63	0.76	0.11	0.18	0.39	0.02

Intersection Summary

# 95th percentile volume exceeds capacity, queue may be longer.  
 Queue shown is maximum after two cycles.

HCM Unsignalized Intersection Capacity Analysis  
 102: SW Woodhaven Dr & SW Sunset Blvd

01/30/2019



Movement	EBL	EBT	EBR	WBL	WBT	WBR	NBL	NBT	NBR	SBL	SBT	SBR
Lane Configurations												
Traffic Volume (veh/h)	51	238	41	7	410	86	17	14	10	27	44	67
Future Volume (Veh/h)	51	238	41	7	410	86	17	14	10	27	44	67
Sign Control		Free			Free			Stop			Stop	
Grade		-1%			1%			-2%			0%	
Peak Hour Factor	0.80	0.80	0.80	0.80	0.80	0.80	0.80	0.80	0.80	0.80	0.80	0.80
Hourly flow rate (vph)	64	298	51	9	513	108	21	18	13	34	55	84
Pedestrians					5						3	
Lane Width (ft)					12.0						12.0	
Walking Speed (ft/s)					3.5						3.5	
Percent Blockage					0						0	
Right turn flare (veh)												
Median type		None			None							
Median storage (veh)												
Upstream signal (ft)		648										
pX, platoon unblocked												
vC, conflicting volume	624			349			1068	1068	303	1041	1065	570
vC1, stage 1 conf vol												
vC2, stage 2 conf vol												
vCu, unblocked vol	624			349			1068	1068	303	1041	1065	570
tC, single (s)	4.2			4.2			7.1	6.5	6.2	7.2	6.5	6.2
tC, 2 stage (s)												
tF (s)	2.3			2.3			3.5	4.0	3.3	3.6	4.0	3.3
p0 queue free %	93			99			83	91	98	80	73	84
cM capacity (veh/h)	926			1146			127	206	738	174	207	523
<b>Direction, Lane #</b>	<b>EB 1</b>	<b>EB 2</b>	<b>EB 3</b>	<b>WB 1</b>	<b>WB 2</b>	<b>NB 1</b>	<b>SB 1</b>					
Volume Total	64	298	51	9	621	52	173					
Volume Left	64	0	0	9	0	21	34					
Volume Right	0	0	51	0	108	13	84					
cSH	926	1700	1700	1146	1700	192	278					
Volume to Capacity	0.07	0.18	0.03	0.01	0.37	0.27	0.62					
Queue Length 95th (ft)	6	0	0	1	0	26	96					
Control Delay (s)	9.2	0.0	0.0	8.2	0.0	30.6	37.1					
Lane LOS	A			A		D	E					
Approach Delay (s)	1.4			0.1		30.6	37.1					
Approach LOS						D	E					
<b>Intersection Summary</b>												
Average Delay			6.8									
Intersection Capacity Utilization			48.8%		ICU Level of Service		A					
Analysis Period (min)			15									

HCM Unsignalized Intersection Capacity Analysis  
 103: SW Timbrel Ln & SW Sunset Blvd

01/30/2019



Movement	EBT	EBR	WBL	WBT	NBL	NBR
Lane Configurations	↻		↻	↻	↻	
Traffic Volume (veh/h)	208	67	71	321	182	45
Future Volume (Veh/h)	208	67	71	321	182	45
Sign Control	Free			Free	Stop	
Grade	-1%			1%	0%	
Peak Hour Factor	0.84	0.84	0.84	0.84	0.84	0.84
Hourly flow rate (vph)	248	80	85	382	217	54
Pedestrians				21	1	
Lane Width (ft)				12.0	12.0	
Walking Speed (ft/s)				3.5	3.5	
Percent Blockage				2	0	
Right turn flare (veh)						
Median type	None			None		
Median storage (veh)						
Upstream signal (ft)	1264					
pX, platoon unblocked						
vC, conflicting volume			329		841	310
vC1, stage 1 conf vol						
vC2, stage 2 conf vol						
vCu, unblocked vol			329		841	310
tC, single (s)			4.2		6.4	6.3
tC, 2 stage (s)						
tF (s)			2.3		3.5	3.4
p0 queue free %			93		29	92
cM capacity (veh/h)			1207		307	704

Direction, Lane #	EB 1	WB 1	WB 2	NB 1
Volume Total	328	85	382	271
Volume Left	0	85	0	217
Volume Right	80	0	0	54
cSH	1700	1207	1700	346
Volume to Capacity	0.19	0.07	0.22	0.78
Queue Length 95th (ft)	0	6	0	161
Control Delay (s)	0.0	8.2	0.0	44.3
Lane LOS		A		E
Approach Delay (s)	0.0	1.5		44.3
Approach LOS				E

Intersection Summary			
Average Delay		11.9	
Intersection Capacity Utilization		42.3%	ICU Level of Service A
Analysis Period (min)		15	

Intersection	
Intersection Delay, s/veh	14
Intersection LOS	B

Movement	EBL	EBT	EBR	WBL	WBT	WBR	NBL	NBT	NBR	SBL	SBT	SBR
Lane Configurations	↶	↷		↶	↷		↶	↷		↶	↷	
Traffic Vol, veh/h	106	244	24	30	171	30	71	127	65	28	37	101
Future Vol, veh/h	106	244	24	30	171	30	71	127	65	28	37	101
Peak Hour Factor	0.90	0.90	0.90	0.90	0.90	0.90	0.90	0.90	0.90	0.90	0.90	0.90
Heavy Vehicles, %	5	2	0	13	2	0	3	2	6	0	5	2
Mvmt Flow	118	271	27	33	190	33	79	141	72	31	41	112
Number of Lanes	1	1	0	1	1	0	1	1	0	1	1	0

Approach	EB	WB	NB	SB
Opposing Approach	WB	EB	SB	NB
Opposing Lanes	2	2	2	2
Conflicting Approach Left	SB	NB	EB	WB
Conflicting Lanes Left	2	2	2	2
Conflicting Approach Right	NB	SB	WB	EB
Conflicting Lanes Right	2	2	2	2
HCM Control Delay	15.5	13.9	13.4	12
HCM LOS	C	B	B	B

Lane	NBLn1	NBLn2	EBLn1	EBLn2	WBLn1	WBLn2	SBLn1	SBLn2
Vol Left, %	100%	0%	100%	0%	100%	0%	100%	0%
Vol Thru, %	0%	66%	0%	91%	0%	85%	0%	27%
Vol Right, %	0%	34%	0%	9%	0%	15%	0%	73%
Sign Control	Stop	Stop	Stop	Stop	Stop	Stop	Stop	Stop
Traffic Vol by Lane	71	192	106	268	30	201	28	138
LT Vol	71	0	106	0	30	0	28	0
Through Vol	0	127	0	244	0	171	0	37
RT Vol	0	65	0	24	0	30	0	101
Lane Flow Rate	79	213	118	298	33	223	31	153
Geometry Grp	7	7	7	7	7	7	7	7
Degree of Util (X)	0.165	0.401	0.235	0.543	0.07	0.42	0.067	0.288
Departure Headway (Hd)	7.543	6.773	7.184	6.559	7.573	6.765	7.711	6.762
Convergence, Y/N	Yes	Yes	Yes	Yes	Yes	Yes	Yes	Yes
Cap	477	533	502	551	473	532	464	531
Service Time	5.263	4.493	4.899	4.274	5.314	4.506	5.456	4.506
HCM Lane V/C Ratio	0.166	0.4	0.235	0.541	0.07	0.419	0.067	0.288
HCM Control Delay	11.8	14	12.1	16.8	10.9	14.3	11	12.2
HCM Lane LOS	B	B	B	C	B	B	B	B
HCM 95th-tile Q	0.6	1.9	0.9	3.2	0.2	2.1	0.2	1.2

Intersection	
Intersection Delay, s/veh	13.1
Intersection LOS	B

Movement	EBL	EBT	EBR	WBL	WBT	WBR	NBL	NBT	NBR	SBL	SBT	SBR
Lane Configurations												
Traffic Vol, veh/h	238	7	202	5	20	23	124	133	3	5	109	61
Future Vol, veh/h	238	7	202	5	20	23	124	133	3	5	109	61
Peak Hour Factor	0.91	0.91	0.91	0.91	0.91	0.91	0.91	0.91	0.91	0.91	0.91	0.91
Heavy Vehicles, %	3	14	4	20	5	0	7	5	67	20	5	8
Mvmt Flow	262	8	222	5	22	25	136	146	3	5	120	67
Number of Lanes	1	1	0	0	1	0	0	1	0	0	1	0

Approach	EB	WB	NB	SB
Opposing Approach	WB	EB	SB	NB
Opposing Lanes	1	2	1	1
Conflicting Approach Left	SB	NB	EB	WB
Conflicting Lanes Left	1	1	2	1
Conflicting Approach Right	NB	SB	WB	EB
Conflicting Lanes Right	1	1	1	2
HCM Control Delay	13.4	10.1	14	11.9
HCM LOS	B	B	B	B

Lane	NBLn1	EBLn1	EBLn2	WBLn1	SBLn1
Vol Left, %	48%	100%	0%	10%	3%
Vol Thru, %	51%	0%	3%	42%	62%
Vol Right, %	1%	0%	97%	48%	35%
Sign Control	Stop	Stop	Stop	Stop	Stop
Traffic Vol by Lane	260	238	209	48	175
LT Vol	124	238	0	5	5
Through Vol	133	0	7	20	109
RT Vol	3	0	202	23	61
Lane Flow Rate	286	262	230	53	192
Geometry Grp	2	7	7	5	2
Degree of Util (X)	0.467	0.477	0.355	0.093	0.32
Departure Headway (Hd)	5.884	6.57	5.567	6.335	5.988
Convergence, Y/N	Yes	Yes	Yes	Yes	Yes
Cap	611	549	645	563	598
Service Time	3.929	4.312	3.308	4.4	4.039
HCM Lane V/C Ratio	0.468	0.477	0.357	0.094	0.321
HCM Control Delay	14	15.2	11.4	10.1	11.9
HCM Lane LOS	B	C	B	B	B
HCM 95th-tile Q	2.5	2.6	1.6	0.3	1.4

HCM Unsignalized Intersection Capacity Analysis  
 106: SW Pacific Hwy & SW Chapman Rd

01/30/2019



Movement	EBL	EBT	EBR	WBL	WBT	WBR	NBU	NBL	NBT	NBR	SBU	SBL
Lane Configurations		↔			↔			↔	↕			↔
Traffic Volume (veh/h)	27	3	2	37	3	39	4	8	1850	84	3	17
Future Volume (Veh/h)	27	3	2	37	3	39	4	8	1850	84	3	17
Sign Control		Stop			Stop				Free			
Grade		0%			0%				0%			
Peak Hour Factor	0.96	0.96	0.96	0.96	0.96	0.96	0.96	0.96	0.96	0.96	0.96	0.96
Hourly flow rate (vph)	28	3	2	39	3	41	0	8	1927	88	0	18
Pedestrians												
Lane Width (ft)												
Walking Speed (ft/s)												
Percent Blockage												
Right turn flare (veh)												
Median type									Raised			
Median storage (veh)									2			
Upstream signal (ft)												
pX, platoon unblocked							0.00				0.00	
vC, conflicting volume	2175	3184	558	2585	3156	1008	0	1133			0	2015
vC1, stage 1 conf vol	1153	1153		1987	1987							
vC2, stage 2 conf vol	1022	2031		598	1169							
vCu, unblocked vol	2175	3184	558	2585	3156	1008	0	1133			0	2015
tC, single (s)	7.7	6.5	6.9	7.6	6.5	7.2	0.0	4.1			0.0	4.1
tC, 2 stage (s)	6.7	5.5		6.6	5.5							
tF (s)	3.6	4.0	3.3	3.5	4.0	3.4	0.0	2.2			0.0	2.2
p0 queue free %	76	96	100	32	97	81	0	99			0	94
cM capacity (veh/h)	119	76	478	58	93	220	0	624			0	287

Direction, Lane #	EB 1	WB 1	NB 1	NB 2	NB 3	SB 1	SB 2	SB 3	SB 4
Volume Total	33	83	8	1285	730	18	558	558	16
Volume Left	28	39	8	0	0	18	0	0	0
Volume Right	2	41	0	0	88	0	0	0	16
cSH	118	93	624	1700	1700	287	1700	1700	1700
Volume to Capacity	0.28	0.89	0.01	0.76	0.43	0.06	0.33	0.33	0.01
Queue Length 95th (ft)	26	125	1	0	0	5	0	0	0
Control Delay (s)	46.7	147.1	10.8	0.0	0.0	18.4	0.0	0.0	0.0
Lane LOS	E	F	B			C			
Approach Delay (s)	46.7	147.1	0.0			0.3			
Approach LOS	E	F							

Intersection Summary		
Average Delay		4.3
Intersection Capacity Utilization	64.9%	ICU Level of Service C
Analysis Period (min)		15

HCM Unsignalized Intersection Capacity Analysis  
 106: SW Pacific Hwy & SW Chapman Rd

01/30/2019



Movement	SBT	SBR
Lane Configurations	↑↑	↑
Traffic Volume (veh/h)	1072	15
Future Volume (Veh/h)	1072	15
Sign Control	Free	
Grade	0%	
Peak Hour Factor	0.96	0.96
Hourly flow rate (vph)	1117	16
Pedestrians		
Lane Width (ft)		
Walking Speed (ft/s)		
Percent Blockage		
Right turn flare (veh)		
Median type	Raised	
Median storage veh)	2	
Upstream signal (ft)		
pX, platoon unblocked		
vC, conflicting volume		
vC1, stage 1 conf vol		
vC2, stage 2 conf vol		
vCu, unblocked vol		
tC, single (s)		
tC, 2 stage (s)		
tF (s)		
p0 queue free %		
cM capacity (veh/h)		
Direction, Lane #		

HCM Unsignalized Intersection Capacity Analysis  
 107: SW Old Hwy 99W & SW Brookman Rd

01/30/2019



Movement	EBL	EBT	EBR	WBL	WBT	WBR	NBL	NBT	NBR	SBL	SBT	SBR
Lane Configurations		↕			↕			↕			↕	
Traffic Volume (veh/h)	10	89	1	0	63	3	2	2	2	8	3	14
Future Volume (Veh/h)	10	89	1	0	63	3	2	2	2	8	3	14
Sign Control		Free			Free			Stop			Stop	
Grade		0%			2%			2%			-2%	
Peak Hour Factor	0.69	0.69	0.69	0.69	0.69	0.69	0.69	0.69	0.69	0.69	0.69	0.69
Hourly flow rate (vph)	14	129	1	0	91	4	3	3	3	12	4	20
Pedestrians												
Lane Width (ft)												
Walking Speed (ft/s)												
Percent Blockage												
Right turn flare (veh)												
Median type		None			None							
Median storage (veh)												
Upstream signal (ft)												
pX, platoon unblocked												
vC, conflicting volume	95			130			272	252	130	255	251	93
vC1, stage 1 conf vol												
vC2, stage 2 conf vol												
vCu, unblocked vol	95			130			272	252	130	255	251	93
tC, single (s)	4.1			4.1			7.6	7.0	6.2	7.1	6.5	6.4
tC, 2 stage (s)												
tF (s)	2.2			2.2			4.0	4.5	3.3	3.5	4.0	3.5
p0 queue free %	99			100			99	99	100	98	99	98
cM capacity (veh/h)	1512			1468			573	571	926	693	650	914
<b>Direction, Lane #</b>	<b>EB 1</b>	<b>WB 1</b>	<b>NB 1</b>	<b>SB 1</b>								
Volume Total	144	95	9	36								
Volume Left	14	0	3	12								
Volume Right	1	4	3	20								
cSH	1512	1468	656	794								
Volume to Capacity	0.01	0.00	0.01	0.05								
Queue Length 95th (ft)	1	0	1	4								
Control Delay (s)	0.8	0.0	10.6	9.8								
Lane LOS	A		B	A								
Approach Delay (s)	0.8	0.0	10.6	9.8								
Approach LOS			B	A								
<b>Intersection Summary</b>												
Average Delay			2.0									
Intersection Capacity Utilization			22.0%		ICU Level of Service				A			
Analysis Period (min)			15									



HCM Unsignalized Intersection Capacity Analysis  
 108: SW Middleton Rd & SW Brookman Rd

01/30/2019



Movement	EBL	EBT	EBR	WBL	WBT	WBR	NBL	NBT	NBR	SBL	SBT	SBR
Lane Configurations		↕			↕			↕			↕	
Traffic Volume (veh/h)	3	87	8	2	56	6	10	10	9	7	4	3
Future Volume (Veh/h)	3	87	8	2	56	6	10	10	9	7	4	3
Sign Control		Stop			Stop			Free			Free	
Grade		-1%			1%			-2%			0%	
Peak Hour Factor	0.72	0.72	0.72	0.72	0.72	0.72	0.72	0.72	0.72	0.72	0.72	0.72
Hourly flow rate (vph)	4	121	11	3	78	8	14	14	13	10	6	4
Pedestrians												
Lane Width (ft)												
Walking Speed (ft/s)												
Percent Blockage												
Right turn flare (veh)												
Median type								None			None	
Median storage (veh)												
Upstream signal (ft)												
pX, platoon unblocked												
vC, conflicting volume	124	83	8	148	78	20	10			27		
vC1, stage 1 conf vol												
vC2, stage 2 conf vol												
vCu, unblocked vol	124	83	8	148	78	20	10			27		
tC, single (s)	7.1	6.5	6.2	7.6	6.6	6.4	4.1			4.1		
tC, 2 stage (s)												
tF (s)	3.5	4.0	3.3	4.0	4.0	3.5	2.2			2.2		
p0 queue free %	99	85	99	100	90	99	99			99		
cM capacity (veh/h)	776	797	1080	625	794	1015	1623			1600		
<b>Direction, Lane #</b>	<b>EB 1</b>	<b>WB 1</b>	<b>NB 1</b>	<b>SB 1</b>								
Volume Total	136	89	41	20								
Volume Left	4	3	14	10								
Volume Right	11	8	13	4								
cSH	814	802	1623	1600								
Volume to Capacity	0.17	0.11	0.01	0.01								
Queue Length 95th (ft)	15	9	1	0								
Control Delay (s)	10.3	10.0	2.5	3.7								
Lane LOS	B	B	A	A								
Approach Delay (s)	10.3	10.0	2.5	3.7								
Approach LOS	B	B										
<b>Intersection Summary</b>												
Average Delay			8.6									
Intersection Capacity Utilization			16.3%		ICU Level of Service				A			
Analysis Period (min)			15									

HCM Unsignalized Intersection Capacity Analysis  
 109: SW Oberst Rd & SW Brookman Rd

01/30/2019



Movement	EBT	EBR	WBL	WBT	NBL	NBR
Lane Configurations	→			←	←	↘
Traffic Volume (veh/h)	105	1	1	60	2	3
Future Volume (Veh/h)	105	1	1	60	2	3
Sign Control	Free			Free	Stop	
Grade	-3%			2%	1%	
Peak Hour Factor	0.68	0.68	0.68	0.68	0.68	0.68
Hourly flow rate (vph)	154	1	1	88	3	4
Pedestrians				1		
Lane Width (ft)				12.0		
Walking Speed (ft/s)				3.5		
Percent Blockage				0		
Right turn flare (veh)						
Median type	None			None		
Median storage (veh)						
Upstream signal (ft)						
pX, platoon unblocked						
vC, conflicting volume			155		244	156
vC1, stage 1 conf vol						
vC2, stage 2 conf vol						
vCu, unblocked vol			155		244	156
tC, single (s)			4.1		6.4	6.5
tC, 2 stage (s)						
tF (s)			2.2		3.5	3.6
p0 queue free %			100		100	100
cM capacity (veh/h)			1438		748	814

Direction, Lane #	EB 1	WB 1	NB 1
Volume Total	155	89	7
Volume Left	0	1	3
Volume Right	1	0	4
cSH	1700	1438	784
Volume to Capacity	0.09	0.00	0.01
Queue Length 95th (ft)	0	0	1
Control Delay (s)	0.0	0.1	9.6
Lane LOS		A	A
Approach Delay (s)	0.0	0.1	9.6
Approach LOS			A

Intersection Summary			
Average Delay		0.3	
Intersection Capacity Utilization	15.9%	ICU Level of Service	A
Analysis Period (min)	15		

HCM Unsignalized Intersection Capacity Analysis  
 110: SW Ladd Hill Rd & SW Brookman Rd

01/30/2019



Movement	EBL	EBR	NBL	NBT	SBT	SBR
Lane Configurations						
Traffic Volume (veh/h)	92	24	18	106	40	38
Future Volume (Veh/h)	92	24	18	106	40	38
Sign Control	Stop			Free	Free	
Grade	2%			-1%	0%	
Peak Hour Factor	0.70	0.70	0.70	0.70	0.70	0.70
Hourly flow rate (vph)	131	34	26	151	57	54
Pedestrians					1	
Lane Width (ft)					12.0	
Walking Speed (ft/s)					3.5	
Percent Blockage					0	
Right turn flare (veh)						
Median type				None	None	
Median storage (veh)						
Upstream signal (ft)						
pX, platoon unblocked						
vC, conflicting volume	288	84	111			
vC1, stage 1 conf vol						
vC2, stage 2 conf vol						
vCu, unblocked vol	288	84	111			
tC, single (s)	6.4	6.3	4.3			
tC, 2 stage (s)						
tF (s)	3.5	3.4	2.4			
p0 queue free %	81	96	98			
cM capacity (veh/h)	688	959	1390			
<b>Direction, Lane #</b>	<b>EB 1</b>	<b>NB 1</b>	<b>SB 1</b>			
Volume Total	165	177	111			
Volume Left	131	26	0			
Volume Right	34	0	54			
cSH	731	1390	1700			
Volume to Capacity	0.23	0.02	0.07			
Queue Length 95th (ft)	22	1	0			
Control Delay (s)	11.4	1.3	0.0			
Lane LOS	B	A				
Approach Delay (s)	11.4	1.3	0.0			
Approach LOS	B					
<b>Intersection Summary</b>						
Average Delay			4.6			
Intersection Capacity Utilization			26.5%	ICU Level of Service	A	
Analysis Period (min)			15			

Queues

101: SW Pacific Hwy & SW Elwert Rd/SW Sunset Blvd

01/30/2019























Lane Group	EBT	EBR	WBT	WBR	NBL	NBT	NBR	SBL	SBT	SBR
Lane Group Flow (vph)	144	313	248	144	233	1077	133	274	1776	14
v/c Ratio	0.36	0.53	0.93	0.33	0.83	0.56	0.15	0.68	0.99	0.02
Control Delay	55.4	9.5	98.3	17.4	88.2	24.7	8.9	75.9	57.7	0.0
Queue Delay	0.0	0.0	0.0	0.0	0.0	0.0	0.0	0.0	0.0	0.0
Total Delay	55.4	9.5	98.3	17.4	88.2	24.7	8.9	75.9	57.7	0.0
Queue Length 50th (ft)	127	8	253	29	234	365	28	141	941	0
Queue Length 95th (ft)	203	97	#438	95	341	475	69	194	#1212	0
Internal Link Dist (ft)	263		568			888			476	
Turn Bay Length (ft)				140	320		150	210		300
Base Capacity (vph)	398	591	269	436	343	1922	906	663	1788	842
Starvation Cap Reductn	0	0	0	0	0	0	0	0	0	0
Spillback Cap Reductn	0	0	0	0	0	0	0	0	0	0
Storage Cap Reductn	0	0	0	0	0	0	0	0	0	0
Reduced v/c Ratio	0.36	0.53	0.92	0.33	0.68	0.56	0.15	0.41	0.99	0.02

Intersection Summary

# 95th percentile volume exceeds capacity, queue may be longer.  
 Queue shown is maximum after two cycles.

HCM Unsignalized Intersection Capacity Analysis  
 102: SW Woodhaven Dr & SW Sunset Blvd

01/30/2019

												
Movement	EBL	EBT	EBR	WBL	WBT	WBR	NBL	NBT	NBR	SBL	SBT	SBR
Lane Configurations												
Traffic Volume (veh/h)	101	344	24	5	370	68	10	0	1	34	1	52
Future Volume (Veh/h)	101	344	24	5	370	68	10	0	1	34	1	52
Sign Control		Free			Free			Stop			Stop	
Grade		-1%			1%			-2%			0%	
Peak Hour Factor	0.92	0.92	0.92	0.92	0.92	0.92	0.92	0.92	0.92	0.92	0.92	0.92
Hourly flow rate (vph)	110	374	26	5	402	74	11	0	1	37	1	57
Pedestrians												
Lane Width (ft)												
Walking Speed (ft/s)												
Percent Blockage												
Right turn flare (veh)												
Median type		None			None							
Median storage (veh)												
Upstream signal (ft)		648										
pX, platoon unblocked				0.98			0.98	0.98	0.98	0.98	0.98	
vC, conflicting volume	476			400			1064	1080	374	1044	1069	439
vC1, stage 1 conf vol												
vC2, stage 2 conf vol												
vCu, unblocked vol	476			380			1056	1072	354	1036	1061	439
tC, single (s)	4.1			4.1			7.1	6.5	6.2	7.1	6.5	6.2
tC, 2 stage (s)												
tF (s)	2.2			2.2			3.5	4.0	3.3	3.5	4.0	3.3
p0 queue free %	90			100			93	100	100	81	99	91
cM capacity (veh/h)	1091			1168			168	196	682	191	198	618
Direction, Lane #	EB 1	EB 2	EB 3	WB 1	WB 2	NB 1	SB 1					
Volume Total	110	374	26	5	476	12	95					
Volume Left	110	0	0	5	0	11	37					
Volume Right	0	0	26	0	74	1	57					
cSH	1091	1700	1700	1168	1700	179	326					
Volume to Capacity	0.10	0.22	0.02	0.00	0.28	0.07	0.29					
Queue Length 95th (ft)	8	0	0	0	0	5	30					
Control Delay (s)	8.7	0.0	0.0	8.1	0.0	26.5	20.5					
Lane LOS	A			A		D	C					
Approach Delay (s)	1.9			0.1		26.5	20.5					
Approach LOS						D	C					
Intersection Summary												
Average Delay			3.0									
Intersection Capacity Utilization			43.9%		ICU Level of Service		A					
Analysis Period (min)			15									

# HCM Unsignalized Intersection Capacity Analysis

## 103: SW Timbrel Ln & SW Sunset Blvd

01/30/2019



Movement	EBT	EBR	WBL	WBT	NBL	NBR
Lane Configurations	↻		↻	↻	↻	
Traffic Volume (veh/h)	276	103	59	360	83	35
Future Volume (Veh/h)	276	103	59	360	83	35
Sign Control	Free			Free	Stop	
Grade	-1%			1%	0%	
Peak Hour Factor	0.91	0.91	0.91	0.91	0.91	0.91
Hourly flow rate (vph)	303	113	65	396	91	38
Pedestrians				1		
Lane Width (ft)				12.0		
Walking Speed (ft/s)				3.5		
Percent Blockage				0		
Right turn flare (veh)						
Median type	None			None		
Median storage (veh)						
Upstream signal (ft)	1264					
pX, platoon unblocked						
vC, conflicting volume			416			886 360
vC1, stage 1 conf vol						
vC2, stage 2 conf vol						
vCu, unblocked vol			416			886 360
tC, single (s)			4.1			6.4 6.2
tC, 2 stage (s)						
tF (s)			2.2			3.5 3.3
p0 queue free %			94			69 94
cM capacity (veh/h)			1138			297 681

Direction, Lane #	EB 1	WB 1	WB 2	NB 1
Volume Total	416	65	396	129
Volume Left	0	65	0	91
Volume Right	113	0	0	38
cSH	1700	1138	1700	356
Volume to Capacity	0.24	0.06	0.23	0.36
Queue Length 95th (ft)	0	5	0	40
Control Delay (s)	0.0	8.4	0.0	20.7
Lane LOS	A		C	
Approach Delay (s)	0.0	1.2	20.7	
Approach LOS	C			

Intersection Summary			
Average Delay	3.2		
Intersection Capacity Utilization	41.1%	ICU Level of Service	A
Analysis Period (min)	15		

Intersection	
Intersection Delay, s/veh	23
Intersection LOS	C

Movement	EBL	EBT	EBR	WBL	WBT	WBR	NBL	NBT	NBR	SBL	SBT	SBR
Lane Configurations	↶	↷		↶	↷		↶	↷		↶	↷	
Traffic Vol, veh/h	25	112	124	32	84	49	91	213	27	65	347	39
Future Vol, veh/h	25	112	124	32	84	49	91	213	27	65	347	39
Peak Hour Factor	0.89	0.89	0.89	0.89	0.89	0.89	0.89	0.89	0.89	0.89	0.89	0.89
Heavy Vehicles, %	0	2	1	3	0	2	0	3	0	2	1	3
Mvmt Flow	28	126	139	36	94	55	102	239	30	73	390	44
Number of Lanes	1	1	0	1	1	0	1	1	0	1	1	0

Approach	EB	WB	NB	SB
Opposing Approach	WB	EB	SB	NB
Opposing Lanes	2	2	2	2
Conflicting Approach Left	SB	NB	EB	WB
Conflicting Lanes Left	2	2	2	2
Conflicting Approach Right	NB	SB	WB	EB
Conflicting Lanes Right	2	2	2	2
HCM Control Delay	18.1	13.9	17	33.5
HCM LOS	C	B	C	D

Lane	NBLn1	NBLn2	EBLn1	EBLn2	WBLn1	WBLn2	SBLn1	SBLn2
Vol Left, %	100%	0%	100%	0%	100%	0%	100%	0%
Vol Thru, %	0%	89%	0%	47%	0%	63%	0%	90%
Vol Right, %	0%	11%	0%	53%	0%	37%	0%	10%
Sign Control	Stop	Stop	Stop	Stop	Stop	Stop	Stop	Stop
Traffic Vol by Lane	91	240	25	236	32	133	65	386
LT Vol	91	0	25	0	32	0	65	0
Through Vol	0	213	0	112	0	84	0	347
RT Vol	0	27	0	124	0	49	0	39
Lane Flow Rate	102	270	28	265	36	149	73	434
Geometry Grp	7	7	7	7	7	7	7	7
Degree of Util (X)	0.223	0.547	0.065	0.546	0.086	0.324	0.154	0.843
Departure Headway (Hd)	7.841	7.299	8.267	7.408	8.639	7.803	7.599	6.998
Convergence, Y/N	Yes	Yes	Yes	Yes	Yes	Yes	Yes	Yes
Cap	456	493	432	485	413	459	470	516
Service Time	5.615	5.073	6.039	5.179	6.423	5.586	5.367	4.765
HCM Lane V/C Ratio	0.224	0.548	0.065	0.546	0.087	0.325	0.155	0.841
HCM Control Delay	12.9	18.6	11.6	18.8	12.2	14.3	11.8	37.1
HCM Lane LOS	B	C	B	C	B	B	B	E
HCM 95th-tile Q	0.8	3.2	0.2	3.2	0.3	1.4	0.5	8.6

Intersection	
Intersection Delay, s/veh	21.2
Intersection LOS	C

Movement	EBL	EBT	EBR	WBL	WBT	WBR	NBL	NBT	NBR	SBL	SBT	SBR
Lane Configurations												
Traffic Vol, veh/h	92	12	154	1	19	15	293	135	6	30	141	251
Future Vol, veh/h	92	12	154	1	19	15	293	135	6	30	141	251
Peak Hour Factor	0.90	0.90	0.90	0.90	0.90	0.90	0.90	0.90	0.90	0.90	0.90	0.90
Heavy Vehicles, %	0	0	5	100	0	0	2	1	0	0	2	2
Mvmt Flow	102	13	171	1	21	17	326	150	7	33	157	279
Number of Lanes	1	1	0	0	1	0	0	1	0	0	1	0

Approach	EB	WB	NB	SB
Opposing Approach	WB	EB	SB	NB
Opposing Lanes	1	2	1	1
Conflicting Approach Left	SB	NB	EB	WB
Conflicting Lanes Left	1	1	2	1
Conflicting Approach Right	NB	SB	WB	EB
Conflicting Lanes Right	1	1	1	2
HCM Control Delay	12.5	13	27.3	20.8
HCM LOS	B	B	D	C

Lane	NBLn1	EBLn1	EBLn2	WBLn1	SBLn1
Vol Left, %	68%	100%	0%	3%	7%
Vol Thru, %	31%	0%	7%	54%	33%
Vol Right, %	1%	0%	93%	43%	59%
Sign Control	Stop	Stop	Stop	Stop	Stop
Traffic Vol by Lane	434	92	166	35	422
LT Vol	293	92	0	1	30
Through Vol	135	0	12	19	141
RT Vol	6	0	154	15	251
Lane Flow Rate	482	102	184	39	469
Geometry Grp	2	7	7	5	2
Degree of Util (X)	0.785	0.22	0.336	0.098	0.708
Departure Headway (Hd)	5.965	7.736	6.56	9.027	5.54
Convergence, Y/N	Yes	Yes	Yes	Yes	Yes
Cap	612	467	551	399	656
Service Time	3.965	5.44	4.26	7.039	3.54
HCM Lane V/C Ratio	0.788	0.218	0.334	0.098	0.715
HCM Control Delay	27.3	12.6	12.5	13	20.8
HCM Lane LOS	D	B	B	B	C
HCM 95th-tile Q	7.5	0.8	1.5	0.3	5.8



HCM Unsignalized Intersection Capacity Analysis  
 106: SW Pacific Hwy & SW Chapman Rd

01/30/2019



Movement	EBL	EBT	EBR	WBL	WBT	WBR	NBU	NBL	NBT	NBR	SBU	SBL
Lane Configurations		↕			↕			↕	↕			↕
Traffic Volume (veh/h)	19	7	11	38	5	27	1	8	1325	43	2	22
Future Volume (Veh/h)	19	7	11	38	5	27	1	8	1325	43	2	22
Sign Control		Stop			Stop				Free			
Grade		0%			0%				0%			
Peak Hour Factor	0.96	0.96	0.96	0.96	0.96	0.96	0.96	0.96	0.96	0.96	0.96	0.96
Hourly flow rate (vph)	20	7	11	40	5	28	0	8	1380	45	0	23
Pedestrians												
Lane Width (ft)												
Walking Speed (ft/s)												
Percent Blockage												
Right turn flare (veh)												
Median type									Raised			
Median storage (veh)									2			
Upstream signal (ft)												
pX, platoon unblocked							0.00				0.00	
vC, conflicting volume	2898	3603	1058	2537	3622	712	0	2158			0	1425
vC1, stage 1 conf vol	2162	2162		1418	1418							
vC2, stage 2 conf vol	736	1441		1118	2204							
vCu, unblocked vol	2898	3603	1058	2537	3622	712	0	2158			0	1425
tC, single (s)	7.6	6.5	6.9	7.6	6.5	6.9	0.0	4.1			0.0	4.1
tC, 2 stage (s)	6.6	5.5		6.6	5.5							
tF (s)	3.5	4.0	3.3	3.5	4.0	3.3	0.0	2.2			0.0	2.2
p0 queue free %	53	90	95	61	92	93	0	97			0	95
cM capacity (veh/h)	43	71	224	103	64	379	0	252			0	484

Direction, Lane #	EB 1	WB 1	NB 1	NB 2	NB 3	SB 1	SB 2	SB 3	SB 4
Volume Total	38	73	8	920	505	23	1058	1058	42
Volume Left	20	40	8	0	0	23	0	0	0
Volume Right	11	28	0	0	45	0	0	0	42
cSH	62	135	252	1700	1700	484	1700	1700	1700
Volume to Capacity	0.62	0.54	0.03	0.54	0.30	0.05	0.62	0.62	0.02
Queue Length 95th (ft)	64	66	2	0	0	4	0	0	0
Control Delay (s)	130.4	59.2	19.7	0.0	0.0	12.8	0.0	0.0	0.0
Lane LOS	F	F	C			B			
Approach Delay (s)	130.4	59.2	0.1			0.1			
Approach LOS	F	F							

Intersection Summary		
Average Delay		2.6
Intersection Capacity Utilization	67.9%	ICU Level of Service C
Analysis Period (min)		15

HCM Unsignalized Intersection Capacity Analysis  
 106: SW Pacific Hwy & SW Chapman Rd

01/30/2019



Movement	SBT	SBR
Lane Configurations	↑↑	↑
Traffic Volume (veh/h)	2031	40
Future Volume (Veh/h)	2031	40
Sign Control	Free	
Grade	0%	
Peak Hour Factor	0.96	0.96
Hourly flow rate (vph)	2116	42
Pedestrians		
Lane Width (ft)		
Walking Speed (ft/s)		
Percent Blockage		
Right turn flare (veh)		
Median type	Raised	
Median storage (veh)	2	
Upstream signal (ft)		
pX, platoon unblocked		
vC, conflicting volume		
vC1, stage 1 conf vol		
vC2, stage 2 conf vol		
vCu, unblocked vol		
tC, single (s)		
tC, 2 stage (s)		
tF (s)		
p0 queue free %		
cM capacity (veh/h)		
Direction, Lane #		

HCM Unsignalized Intersection Capacity Analysis  
 107: SW Old Hwy 99W & SW Brookman Rd

01/30/2019



Movement	EBL	EBT	EBR	WBL	WBT	WBR	NBL	NBT	NBR	SBL	SBT	SBR
Lane Configurations		↕			↕			↕			↕	
Traffic Volume (veh/h)	9	56	1	1	65	2	1	1	2	1	1	1
Future Volume (Veh/h)	9	56	1	1	65	2	1	1	2	1	1	1
Sign Control		Free			Free			Stop			Stop	
Grade		0%			2%			2%			-2%	
Peak Hour Factor	0.82	0.82	0.82	0.82	0.82	0.82	0.82	0.82	0.82	0.82	0.82	0.82
Hourly flow rate (vph)	11	68	1	1	79	2	1	1	2	1	1	1
Pedestrians												
Lane Width (ft)												
Walking Speed (ft/s)												
Percent Blockage												
Right turn flare (veh)												
Median type		None			None							
Median storage (veh)												
Upstream signal (ft)												
pX, platoon unblocked												
vC, conflicting volume	81			69			174	174	68	175	173	80
vC1, stage 1 conf vol												
vC2, stage 2 conf vol												
vCu, unblocked vol	81			69			174	174	68	175	173	80
tC, single (s)	4.1			4.1			7.1	6.5	6.2	7.1	6.5	6.2
tC, 2 stage (s)												
tF (s)	2.2			2.2			3.5	4.0	3.3	3.5	4.0	3.3
p0 queue free %	99			100			100	100	100	100	100	100
cM capacity (veh/h)	1529			1545			787	718	1000	785	718	986
<b>Direction, Lane #</b>	<b>EB 1</b>	<b>WB 1</b>	<b>NB 1</b>	<b>SB 1</b>								
Volume Total	80	82	4	3								
Volume Left	11	1	1	1								
Volume Right	1	2	2	1								
cSH	1529	1545	858	815								
Volume to Capacity	0.01	0.00	0.00	0.00								
Queue Length 95th (ft)	1	0	0	0								
Control Delay (s)	1.1	0.1	9.2	9.4								
Lane LOS	A	A	A	A								
Approach Delay (s)	1.1	0.1	9.2	9.4								
Approach LOS			A	A								
<b>Intersection Summary</b>												
Average Delay			0.9									
Intersection Capacity Utilization			18.5%		ICU Level of Service				A			
Analysis Period (min)			15									

# HCM Unsignalized Intersection Capacity Analysis

## 108: SW Middleton Rd & SW Brookman Rd

01/30/2019



Movement	EBL	EBT	EBR	WBL	WBT	WBR	NBL	NBT	NBR	SBL	SBT	SBR
Lane Configurations		↕			↕			↕			↕	
Traffic Volume (veh/h)	9	40	14	11	47	3	13	6	8	2	9	4
Future Volume (Veh/h)	9	40	14	11	47	3	13	6	8	2	9	4
Sign Control		Stop			Stop			Free			Free	
Grade		-1%			1%			-2%			0%	
Peak Hour Factor	0.74	0.74	0.74	0.74	0.74	0.74	0.74	0.74	0.74	0.74	0.74	0.74
Hourly flow rate (vph)	12	54	19	15	64	4	18	8	11	3	12	5
Pedestrians		1			1						1	
Lane Width (ft)		12.0			12.0						12.0	
Walking Speed (ft/s)		3.5			3.5						3.5	
Percent Blockage		0			0						0	
Right turn flare (veh)												
Median type								None			None	
Median storage (veh)												
Upstream signal (ft)												
pX, platoon unblocked												
vC, conflicting volume	108	78	16	117	74	16	18			20		
vC1, stage 1 conf vol												
vC2, stage 2 conf vol												
vCu, unblocked vol	108	78	16	117	74	16	18			20		
tC, single (s)	7.1	6.5	6.2	7.2	6.5	6.2	4.2			4.1		
tC, 2 stage (s)												
tF (s)	3.5	4.0	3.3	3.6	4.0	3.3	2.3			2.2		
p0 queue free %	99	93	98	98	92	100	99			100		
cM capacity (veh/h)	808	804	1069	775	807	1068	1517			1608		
<b>Direction, Lane #</b>	<b>EB 1</b>	<b>WB 1</b>	<b>NB 1</b>	<b>SB 1</b>								
Volume Total	85	83	37	20								
Volume Left	12	15	18	3								
Volume Right	19	4	11	5								
cSH	852	811	1517	1608								
Volume to Capacity	0.10	0.10	0.01	0.00								
Queue Length 95th (ft)	8	9	1	0								
Control Delay (s)	9.7	9.9	3.6	1.1								
Lane LOS	A	A	A	A								
Approach Delay (s)	9.7	9.9	3.6	1.1								
Approach LOS	A	A										
<b>Intersection Summary</b>												
Average Delay			8.0									
Intersection Capacity Utilization			16.1%		ICU Level of Service				A			
Analysis Period (min)			15									

# HCM Unsignalized Intersection Capacity Analysis

## 109: SW Oberst Rd & SW Brookman Rd

01/30/2019



Movement	EBT	EBR	WBL	WBT	NBL	NBR
Lane Configurations	↻			↻	↻	
Traffic Volume (veh/h)	48	0	4	63	4	4
Future Volume (Veh/h)	48	0	4	63	4	4
Sign Control	Free			Free	Stop	
Grade	-3%			2%	1%	
Peak Hour Factor	0.69	0.69	0.69	0.69	0.69	0.69
Hourly flow rate (vph)	70	0	6	91	6	6
Pedestrians						
Lane Width (ft)						
Walking Speed (ft/s)						
Percent Blockage						
Right turn flare (veh)						
Median type	None			None		
Median storage (veh)						
Upstream signal (ft)						
pX, platoon unblocked						
vC, conflicting volume			70		173	70
vC1, stage 1 conf vol						
vC2, stage 2 conf vol						
vCu, unblocked vol			70		173	70
tC, single (s)			4.1		6.7	6.5
tC, 2 stage (s)						
tF (s)			2.2		3.7	3.5
p0 queue free %			100		99	99
cM capacity (veh/h)			1544		764	932
Direction, Lane #	EB 1	WB 1	NB 1			
Volume Total	70	97	12			
Volume Left	0	6	6			
Volume Right	0	0	6			
cSH	1700	1544	840			
Volume to Capacity	0.04	0.00	0.01			
Queue Length 95th (ft)	0	0	1			
Control Delay (s)	0.0	0.5	9.4			
Lane LOS		A	A			
Approach Delay (s)	0.0	0.5	9.4			
Approach LOS			A			
Intersection Summary						
Average Delay			0.9			
Intersection Capacity Utilization			16.6%	ICU Level of Service	A	
Analysis Period (min)			15			

# HCM Unsignalized Intersection Capacity Analysis

## 110: SW Ladd Hill Rd & SW Brookman Rd

01/30/2019



Movement	EBL	EBR	NBL	NBT	SBT	SBR
Lane Configurations						
Traffic Volume (veh/h)	33	15	9	81	90	52
Future Volume (Veh/h)	33	15	9	81	90	52
Sign Control	Stop			Free	Free	
Grade	2%			-1%	0%	
Peak Hour Factor	0.78	0.78	0.78	0.78	0.78	0.78
Hourly flow rate (vph)	42	19	12	104	115	67
<b>Pedestrians</b>						
Lane Width (ft)						
Walking Speed (ft/s)						
Percent Blockage						
Right turn flare (veh)						
Median type				None	None	
Median storage (veh)						
Upstream signal (ft)						
pX, platoon unblocked						
vC, conflicting volume	276	148	182			
vC1, stage 1 conf vol						
vC2, stage 2 conf vol						
vCu, unblocked vol	276	148	182			
tC, single (s)	6.4	6.3	4.1			
tC, 2 stage (s)						
tF (s)	3.5	3.4	2.2			
p0 queue free %	94	98	99			
cM capacity (veh/h)	705	885	1405			
<b>Direction, Lane #</b>	<b>EB 1</b>	<b>NB 1</b>	<b>SB 1</b>			
Volume Total	61	116	182			
Volume Left	42	12	0			
Volume Right	19	0	67			
cSH	753	1405	1700			
Volume to Capacity	0.08	0.01	0.11			
Queue Length 95th (ft)	7	1	0			
Control Delay (s)	10.2	0.8	0.0			
Lane LOS	B	A				
Approach Delay (s)	10.2	0.8	0.0			
Approach LOS	B					
<b>Intersection Summary</b>						
Average Delay			2.0			
Intersection Capacity Utilization			21.8%	ICU Level of Service	A	
Analysis Period (min)			15			

Queues

101: SW Pacific Hwy & SW Elwert Rd/SW Sunset Blvd

02/05/2019



Lane Group	EBL	EBT	WBL	WBT	NBL	NBT	NBR	SBL	SBT	SBR
Lane Group Flow (vph)	138	543	114	638	348	1659	118	136	795	204
v/c Ratio	0.89	0.66	0.79	0.86	0.82	0.97	0.15	0.58	0.55	0.26
Control Delay	117.7	42.0	105.6	66.3	84.0	53.9	8.4	81.0	34.7	4.2
Queue Delay	0.0	0.0	0.0	0.0	0.0	0.0	0.0	0.0	0.0	0.0
Total Delay	117.7	42.0	105.6	66.3	84.0	53.9	8.4	81.0	34.7	4.2
Queue Length 50th (ft)	148	188	120	307	186	910	19	72	333	0
Queue Length 95th (ft)	#287	256	#227	385	#247	#1096	57	110	402	51
Internal Link Dist (ft)		263		568		888			476	
Turn Bay Length (ft)					320		150	210		300
Base Capacity (vph)	155	891	152	829	458	1717	811	264	1453	780
Starvation Cap Reductn	0	0	0	0	0	0	0	0	0	0
Spillback Cap Reductn	0	0	0	0	0	0	0	0	0	0
Storage Cap Reductn	0	0	0	0	0	0	0	0	0	0
Reduced v/c Ratio	0.89	0.61	0.75	0.77	0.76	0.97	0.15	0.52	0.55	0.26

Intersection Summary

# 95th percentile volume exceeds capacity, queue may be longer.  
 Queue shown is maximum after two cycles.

HCM Unsignalized Intersection Capacity Analysis  
 102: SW Woodhaven Dr & SW Sunset Blvd

02/05/2019



Movement	EBL	EBT	EBR	WBL	WBT	WBR	NBL	NBT	NBR	SBL	SBT	SBR
Lane Configurations												
Traffic Volume (veh/h)	55	338	74	7	562	91	20	15	11	29	47	119
Future Volume (Veh/h)	55	338	74	7	562	91	20	15	11	29	47	119
Sign Control		Free			Free			Stop			Stop	
Grade		-1%			1%			-2%			0%	
Peak Hour Factor	0.80	0.80	0.80	0.80	0.80	0.80	0.80	0.80	0.80	0.80	0.80	0.80
Hourly flow rate (vph)	69	423	93	9	703	114	25	19	14	36	59	149
Pedestrians					5						3	
Lane Width (ft)					12.0						12.0	
Walking Speed (ft/s)					3.5						3.5	
Percent Blockage					0						0	
Right turn flare (veh)												
Median type		None			None							
Median storage (veh)												
Upstream signal (ft)		648										
pX, platoon unblocked				0.91			0.91	0.91	0.91	0.91	0.91	
vC, conflicting volume	820			516			1460	1399	428	1370	1435	763
vC1, stage 1 conf vol												
vC2, stage 2 conf vol												
vCu, unblocked vol	820			420			1457	1389	324	1358	1429	763
tC, single (s)	4.2			4.2			7.1	6.5	6.2	7.2	6.5	6.2
tC, 2 stage (s)												
tF (s)	2.3			2.3			3.5	4.0	3.3	3.6	4.0	3.3
p0 queue free %	91			99			27	84	98	59	47	63
cM capacity (veh/h)	781			982			34	118	655	88	112	406
Direction, Lane #	EB 1	EB 2	EB 3	WB 1	WB 2	NB 1	SB 1					
Volume Total	69	423	93	9	817	58	244					
Volume Left	69	0	0	9	0	25	36					
Volume Right	0	0	93	0	114	14	149					
cSH	781	1700	1700	982	1700	63	187					
Volume to Capacity	0.09	0.25	0.05	0.01	0.48	0.91	1.30					
Queue Length 95th (ft)	7	0	0	1	0	108	344					
Control Delay (s)	10.1	0.0	0.0	8.7	0.0	196.4	218.3					
Lane LOS	B			A		F	F					
Approach Delay (s)	1.2			0.1		196.4	218.3					
Approach LOS						F	F					
Intersection Summary												
Average Delay			38.2									
Intersection Capacity Utilization			60.4%			ICU Level of Service			B			
Analysis Period (min)			15									



# HCM Unsignalized Intersection Capacity Analysis

## 103: SW Timbrel Ln & SW Sunset Blvd

02/05/2019

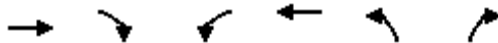

Movement	EBT	EBR	WBL	WBT	NBL	NBR
Lane Configurations	↻		↻	↻	↻	
Traffic Volume (veh/h)	303	74	75	462	198	48
Future Volume (Veh/h)	303	74	75	462	198	48
Sign Control	Free			Free	Stop	
Grade	-1%			1%	0%	
Peak Hour Factor	0.84	0.84	0.84	0.84	0.84	0.84
Hourly flow rate (vph)	361	88	89	550	236	57
Pedestrians				21	1	
Lane Width (ft)				12.0	12.0	
Walking Speed (ft/s)				3.5	3.5	
Percent Blockage				2	0	
Right turn flare (veh)						
Median type	None			None		
Median storage (veh)						
Upstream signal (ft)	1264					
pX, platoon unblocked						
vC, conflicting volume			450	1134		427
vC1, stage 1 conf vol						
vC2, stage 2 conf vol						
vCu, unblocked vol			450	1134		427
tC, single (s)			4.2	6.4		6.3
tC, 2 stage (s)						
tF (s)			2.3	3.5		3.4
p0 queue free %			92	0		91
cM capacity (veh/h)			1089	203		604

Direction, Lane #	EB 1	WB 1	WB 2	NB 1
Volume Total	449	89	550	293
Volume Left	0	89	0	236
Volume Right	88	0	0	57
cSH	1700	1089	1700	233
Volume to Capacity	0.26	0.08	0.32	1.26
Queue Length 95th (ft)	0	7	0	372
Control Delay (s)	0.0	8.6	0.0	188.7
Lane LOS	A		F	
Approach Delay (s)	0.0	1.2	188.7	
Approach LOS	F			

Intersection Summary			
Average Delay	40.6		
Intersection Capacity Utilization	48.9%	ICU Level of Service	A
Analysis Period (min)	15		

Intersection	
Intersection Delay, s/veh	21.5
Intersection LOS	C

Movement	EBL	EBT	EBR	WBL	WBT	WBR	NBL	NBT	NBR	SBL	SBT	SBR
Lane Configurations	↶	↷		↶	↷		↶	↷		↶	↷	
Traffic Vol, veh/h	112	311	39	32	265	32	89	135	69	30	39	107
Future Vol, veh/h	112	311	39	32	265	32	89	135	69	30	39	107
Peak Hour Factor	0.90	0.90	0.90	0.90	0.90	0.90	0.90	0.90	0.90	0.90	0.90	0.90
Heavy Vehicles, %	5	2	0	13	2	0	3	2	6	0	5	2
Mvmt Flow	124	346	43	36	294	36	99	150	77	33	43	119
Number of Lanes	1	1	0	1	1	0	1	1	0	1	1	0

Approach	EB	WB	NB	SB
Opposing Approach	WB	EB	SB	NB
Opposing Lanes	2	2	2	2
Conflicting Approach Left	SB	NB	EB	WB
Conflicting Lanes Left	2	2	2	2
Conflicting Approach Right	NB	SB	WB	EB
Conflicting Lanes Right	2	2	2	2
HCM Control Delay	26.4	23.3	16.2	14.2
HCM LOS	D	C	C	B

Lane	NBLn1	NBLn2	EBLn1	EBLn2	WBLn1	WBLn2	SBLn1	SBLn2
Vol Left, %	100%	0%	100%	0%	100%	0%	100%	0%
Vol Thru, %	0%	66%	0%	89%	0%	89%	0%	27%
Vol Right, %	0%	34%	0%	11%	0%	11%	0%	73%
Sign Control	Stop	Stop	Stop	Stop	Stop	Stop	Stop	Stop
Traffic Vol by Lane	89	204	112	350	32	297	30	146
LT Vol	89	0	112	0	32	0	30	0
Through Vol	0	135	0	311	0	265	0	39
RT Vol	0	69	0	39	0	32	0	107
Lane Flow Rate	99	227	124	389	36	330	33	162
Geometry Grp	7	7	7	7	7	7	7	7
Degree of Util (X)	0.23	0.479	0.27	0.774	0.081	0.679	0.08	0.348
Departure Headway (Hd)	8.39	7.613	7.807	7.162	8.186	7.402	8.693	7.733
Convergence, Y/N	Yes	Yes	Yes	Yes	Yes	Yes	Yes	Yes
Cap	427	471	459	506	437	485	411	462
Service Time	6.165	5.387	5.574	4.929	5.956	5.172	6.477	5.516
HCM Lane V/C Ratio	0.232	0.482	0.27	0.769	0.082	0.68	0.08	0.351
HCM Control Delay	13.7	17.3	13.5	30.5	11.7	24.5	12.2	14.6
HCM Lane LOS	B	C	B	D	B	C	B	B
HCM 95th-tile Q	0.9	2.5	1.1	6.9	0.3	5	0.3	1.5

Intersection	
Intersection Delay, s/veh	15.2
Intersection LOS	C

Movement	EBL	EBT	EBR	WBL	WBT	WBR	NBL	NBT	NBR	SBL	SBT	SBR
Lane Configurations												
Traffic Vol, veh/h	272	9	219	5	23	24	138	141	3	5	116	103
Future Vol, veh/h	272	9	219	5	23	24	138	141	3	5	116	103
Peak Hour Factor	0.91	0.91	0.91	0.91	0.91	0.91	0.91	0.91	0.91	0.91	0.91	0.91
Heavy Vehicles, %	3	14	4	20	5	0	7	5	67	20	5	8
Mvmt Flow	299	10	241	5	25	26	152	155	3	5	127	113
Number of Lanes	1	1	0	0	1	0	0	1	0	0	1	0

Approach	EB	WB	NB	SB
Opposing Approach	WB	EB	SB	NB
Opposing Lanes	1	2	1	1
Conflicting Approach Left	SB	NB	EB	WB
Conflicting Lanes Left	1	1	2	1
Conflicting Approach Right	NB	SB	WB	EB
Conflicting Lanes Right	1	1	1	2
HCM Control Delay	15.8	10.8	16.2	13.8
HCM LOS	C	B	C	B

Lane	NBLn1	EBLn1	EBLn2	WBLn1	SBLn1
Vol Left, %	49%	100%	0%	10%	2%
Vol Thru, %	50%	0%	4%	44%	52%
Vol Right, %	1%	0%	96%	46%	46%
Sign Control	Stop	Stop	Stop	Stop	Stop
Traffic Vol by Lane	282	272	228	52	224
LT Vol	138	272	0	5	5
Through Vol	141	0	9	23	116
RT Vol	3	0	219	24	103
Lane Flow Rate	310	299	251	57	246
Geometry Grp	2	7	7	5	2
Degree of Util (X)	0.533	0.57	0.408	0.11	0.423
Departure Headway (Hd)	6.196	6.864	5.862	6.91	6.19
Convergence, Y/N	Yes	Yes	Yes	Yes	Yes
Cap	579	523	611	522	578
Service Time	4.268	4.629	3.626	4.91	4.266
HCM Lane V/C Ratio	0.535	0.572	0.411	0.109	0.426
HCM Control Delay	16.2	18.4	12.6	10.8	13.8
HCM Lane LOS	C	C	B	B	B
HCM 95th-tile Q	3.1	3.5	2	0.4	2.1

HCM Unsignalized Intersection Capacity Analysis  
 106: SW Pacific Hwy & SW Chapman Rd

02/05/2019



Movement	EBL	EBT	EBR	WBL	WBT	WBR	NBU	NBL	NBT	NBR	SBU	SBL
Lane Configurations		↔			↔			↔	↕			↔
Traffic Volume (veh/h)	30	3	2	39	3	52	4	8	1914	89	3	25
Future Volume (Veh/h)	30	3	2	39	3	52	4	8	1914	89	3	25
Sign Control		Stop			Stop				Free			
Grade		0%			0%				0%			
Peak Hour Factor	0.96	0.96	0.96	0.96	0.96	0.96	0.96	0.96	0.96	0.96	0.96	0.96
Hourly flow rate (vph)	31	3	2	41	3	54	0	8	1994	93	0	26
Pedestrians												
Lane Width (ft)												
Walking Speed (ft/s)												
Percent Blockage												
Right turn flare (veh)												
Median type									Raised			
Median storage (veh)									2			
Upstream signal (ft)												
pX, platoon unblocked							0.00				0.00	
vC, conflicting volume	2272	3307	576	2688	3278	1044	0	1169			0	2087
vC1, stage 1 conf vol	1204	1204		2056	2056							
vC2, stage 2 conf vol	1068	2103		632	1221							
vCu, unblocked vol	2272	3307	576	2688	3278	1044	0	1169			0	2087
tC, single (s)	7.7	6.5	6.9	7.6	6.5	7.2	0.0	4.1			0.0	4.1
tC, 2 stage (s)	6.7	5.5		6.6	5.5							
tF (s)	3.6	4.0	3.3	3.5	4.0	3.4	0.0	2.2			0.0	2.2
p0 queue free %	68	95	100	21	96	74	0	99			0	90
cM capacity (veh/h)	98	62	466	52	86	208	0	605			0	269

Direction, Lane #	EB 1	WB 1	NB 1	NB 2	NB 3	SB 1	SB 2	SB 3	SB 4
Volume Total	36	98	8	1329	758	26	576	576	17
Volume Left	31	41	8	0	0	26	0	0	0
Volume Right	2	54	0	0	93	0	0	0	17
cSH	98	90	605	1700	1700	269	1700	1700	1700
Volume to Capacity	0.37	1.08	0.01	0.78	0.45	0.10	0.34	0.34	0.01
Queue Length 95th (ft)	37	164	1	0	0	8	0	0	0
Control Delay (s)	61.9	204.2	11.0	0.0	0.0	19.8	0.0	0.0	0.0
Lane LOS	F	F	B			C			
Approach Delay (s)	61.9	204.2	0.0			0.4			
Approach LOS	F	F							

Intersection Summary

Average Delay	6.7
Intersection Capacity Utilization	67.6%
ICU Level of Service	C
Analysis Period (min)	15

HCM Unsignalized Intersection Capacity Analysis  
 106: SW Pacific Hwy & SW Chapman Rd

02/05/2019



Movement	SBT	SBR
Lane Configurations	↑↑	↑
Traffic Volume (veh/h)	1106	16
Future Volume (Veh/h)	1106	16
Sign Control	Free	
Grade	0%	
Peak Hour Factor	0.96	0.96
Hourly flow rate (vph)	1152	17
Pedestrians		
Lane Width (ft)		
Walking Speed (ft/s)		
Percent Blockage		
Right turn flare (veh)		
Median type	Raised	
Median storage veh)	2	
Upstream signal (ft)		
pX, platoon unblocked		
vC, conflicting volume		
vC1, stage 1 conf vol		
vC2, stage 2 conf vol		
vCu, unblocked vol		
tC, single (s)		
tC, 2 stage (s)		
tF (s)		
p0 queue free %		
cM capacity (veh/h)		
Direction, Lane #		

HCM Unsignalized Intersection Capacity Analysis  
 107: SW Old Hwy 99W & SW Brookman Rd

02/05/2019



Movement	EBL	EBT	EBR	WBL	WBT	WBR	NBL	NBT	NBR	SBL	SBT	SBR
Lane Configurations		↕			↕			↕			↕	
Traffic Volume (veh/h)	11	104	2	0	73	3	3	2	2	8	3	15
Future Volume (Veh/h)	11	104	2	0	73	3	3	2	2	8	3	15
Sign Control		Free			Free			Stop			Stop	
Grade		0%			2%			2%			-2%	
Peak Hour Factor	0.69	0.69	0.69	0.69	0.69	0.69	0.69	0.69	0.69	0.69	0.69	0.69
Hourly flow rate (vph)	16	151	3	0	106	4	4	3	3	12	4	22
Pedestrians												
Lane Width (ft)												
Walking Speed (ft/s)												
Percent Blockage												
Right turn flare (veh)												
Median type		None			None							
Median storage (veh)												
Upstream signal (ft)												
pX, platoon unblocked												
vC, conflicting volume	110			154			316	294	152	297	294	108
vC1, stage 1 conf vol												
vC2, stage 2 conf vol												
vCu, unblocked vol	110			154			316	294	152	297	294	108
tC, single (s)	4.1			4.1			7.6	7.0	6.2	7.1	6.5	6.4
tC, 2 stage (s)												
tF (s)	2.2			2.2			4.0	4.5	3.3	3.5	4.0	3.5
p0 queue free %	99			100			99	99	100	98	99	98
cM capacity (veh/h)	1493			1439			532	538	899	649	614	897
<b>Direction, Lane #</b>	<b>EB 1</b>	<b>WB 1</b>	<b>NB 1</b>	<b>SB 1</b>								
Volume Total	170	110	10	38								
Volume Left	16	0	4	12								
Volume Right	3	4	3	22								
cSH	1493	1439	609	767								
Volume to Capacity	0.01	0.00	0.02	0.05								
Queue Length 95th (ft)	1	0	1	4								
Control Delay (s)	0.8	0.0	11.0	9.9								
Lane LOS	A		B	A								
Approach Delay (s)	0.8	0.0	11.0	9.9								
Approach LOS			B	A								
<b>Intersection Summary</b>												
Average Delay			1.9									
Intersection Capacity Utilization			22.9%		ICU Level of Service				A			
Analysis Period (min)			15									

HCM Unsignalized Intersection Capacity Analysis  
 108: SW Middleton Rd & SW Brookman Rd

02/05/2019



Movement	EBL	EBT	EBR	WBL	WBT	WBR	NBL	NBT	NBR	SBL	SBT	SBR
Lane Configurations		↕			↕			↕			↕	
Traffic Volume (veh/h)	3	94	17	2	60	6	16	11	10	7	4	3
Future Volume (Veh/h)	3	94	17	2	60	6	16	11	10	7	4	3
Sign Control		Stop			Stop			Free			Free	
Grade		-1%			1%			-2%			0%	
Peak Hour Factor	0.72	0.72	0.72	0.72	0.72	0.72	0.72	0.72	0.72	0.72	0.72	0.72
Hourly flow rate (vph)	4	131	24	3	83	8	22	15	14	10	6	4
Pedestrians												
Lane Width (ft)												
Walking Speed (ft/s)												
Percent Blockage												
Right turn flare (veh)												
Median type								None			None	
Median storage (veh)												
Upstream signal (ft)												
pX, platoon unblocked												
vC, conflicting volume	144	101	8	184	96	22	10			29		
vC1, stage 1 conf vol												
vC2, stage 2 conf vol												
vCu, unblocked vol	144	101	8	184	96	22	10			29		
tC, single (s)	7.1	6.5	6.2	7.6	6.6	6.4	4.1			4.1		
tC, 2 stage (s)												
tF (s)	3.5	4.0	3.3	4.0	4.0	3.5	2.2			2.2		
p0 queue free %	99	83	98	99	89	99	99			99		
cM capacity (veh/h)	745	775	1080	573	773	1013	1623			1597		
<b>Direction, Lane #</b>	<b>EB 1</b>	<b>WB 1</b>	<b>NB 1</b>	<b>SB 1</b>								
Volume Total	159	94	51	20								
Volume Left	4	3	22	10								
Volume Right	24	8	14	4								
cSH	809	780	1623	1597								
Volume to Capacity	0.20	0.12	0.01	0.01								
Queue Length 95th (ft)	18	10	1	0								
Control Delay (s)	10.5	10.2	3.2	3.7								
Lane LOS	B	B	A	A								
Approach Delay (s)	10.5	10.2	3.2	3.7								
Approach LOS	B	B										
<b>Intersection Summary</b>												
Average Delay			8.9									
Intersection Capacity Utilization			17.3%		ICU Level of Service				A			
Analysis Period (min)			15									

# HCM Unsignalized Intersection Capacity Analysis

## 109: SW Oberst Rd & SW Brookman Rd

02/05/2019



Movement	EBT	EBR	WBL	WBT	NBL	NBR
Lane Configurations	→			←	↔	↔
Traffic Volume (veh/h)	111	3	1	64	3	3
Future Volume (Veh/h)	111	3	1	64	3	3
Sign Control	Free			Free	Stop	
Grade	-3%			2%	1%	
Peak Hour Factor	0.68	0.68	0.68	0.68	0.68	0.68
Hourly flow rate (vph)	163	4	1	94	4	4
Pedestrians				1		
Lane Width (ft)				12.0		
Walking Speed (ft/s)				3.5		
Percent Blockage				0		
Right turn flare (veh)						
Median type	None			None		
Median storage (veh)						
Upstream signal (ft)						
pX, platoon unblocked						
vC, conflicting volume			167			166
vC1, stage 1 conf vol						
vC2, stage 2 conf vol						
vCu, unblocked vol			167			166
tC, single (s)			4.1			6.5
tC, 2 stage (s)						
tF (s)			2.2			3.6
p0 queue free %			100			100
cM capacity (veh/h)			1423			803
Direction, Lane #	EB 1	WB 1	NB 1			
Volume Total	167	95	8			
Volume Left	0	1	4			
Volume Right	4	0	4			
cSH	1700	1423	766			
Volume to Capacity	0.10	0.00	0.01			
Queue Length 95th (ft)	0	0	1			
Control Delay (s)	0.0	0.1	9.8			
Lane LOS			A			
Approach Delay (s)	0.0	0.1	9.8			
Approach LOS			A			
Intersection Summary						
Average Delay			0.3			
Intersection Capacity Utilization			16.4%	ICU Level of Service	A	
Analysis Period (min)			15			



# HCM Unsignalized Intersection Capacity Analysis

## 110: SW Ladd Hill Rd & SW Brookman Rd

02/05/2019



Movement	EBL	EBR	NBL	NBT	SBT	SBR
Lane Configurations						
Traffic Volume (veh/h)	98	25	19	112	42	40
Future Volume (Veh/h)	98	25	19	112	42	40
Sign Control	Stop			Free	Free	
Grade	2%			-1%	0%	
Peak Hour Factor	0.70	0.70	0.70	0.70	0.70	0.70
Hourly flow rate (vph)	140	36	27	160	60	57
Pedestrians					1	
Lane Width (ft)					12.0	
Walking Speed (ft/s)					3.5	
Percent Blockage					0	
Right turn flare (veh)						
Median type				None	None	
Median storage (veh)						
Upstream signal (ft)						
pX, platoon unblocked						
vC, conflicting volume	304	88	117			
vC1, stage 1 conf vol						
vC2, stage 2 conf vol						
vCu, unblocked vol	304	88	117			
tC, single (s)	6.4	6.3	4.3			
tC, 2 stage (s)						
tF (s)	3.5	3.4	2.4			
p0 queue free %	79	96	98			
cM capacity (veh/h)	674	953	1383			
<b>Direction, Lane #</b>	<b>EB 1</b>	<b>NB 1</b>	<b>SB 1</b>			
Volume Total	176	187	117			
Volume Left	140	27	0			
Volume Right	36	0	57			
cSH	717	1383	1700			
Volume to Capacity	0.25	0.02	0.07			
Queue Length 95th (ft)	24	1	0			
Control Delay (s)	11.6	1.2	0.0			
Lane LOS	B	A				
Approach Delay (s)	11.6	1.2	0.0			
Approach LOS	B					
<b>Intersection Summary</b>						
Average Delay			4.8			
Intersection Capacity Utilization			27.2%	ICU Level of Service	A	
Analysis Period (min)			15			

Queues

101: SW Pacific Hwy & SW Elwert Rd/SW Sunset Blvd

02/05/2019



Lane Group	EBL	EBT	WBL	WBT	NBL	NBT	NBR	SBL	SBT	SBR
Lane Group Flow (vph)	48	516	144	305	260	1100	141	296	1823	48
v/c Ratio	0.48	0.92dr	0.97	0.40	0.96	0.62	0.17	0.80	0.97	0.05
Control Delay	86.6	54.5	133.4	29.8	113.8	30.3	10.0	83.8	50.3	0.6
Queue Delay	0.0	0.0	0.0	0.0	0.0	0.0	0.0	0.0	0.0	0.0
Total Delay	86.6	54.5	133.4	29.8	113.8	30.3	10.0	83.8	50.3	0.6
Queue Length 50th (ft)	47	192	146	74	136	413	29	151	908	0
Queue Length 95th (ft)	98	260	#315	123	#250	555	78	#236	#1241	4
Internal Link Dist (ft)		263		568		888			476	
Turn Bay Length (ft)					320		150	210		300
Base Capacity (vph)	125	814	149	859	272	1764	844	384	1873	893
Starvation Cap Reductn	0	0	0	0	0	0	0	0	0	0
Spillback Cap Reductn	0	0	0	0	0	0	0	0	0	0
Storage Cap Reductn	0	0	0	0	0	0	0	0	0	0
Reduced v/c Ratio	0.38	0.63	0.97	0.36	0.96	0.62	0.17	0.77	0.97	0.05





















Intersection Summary

- # 95th percentile volume exceeds capacity, queue may be longer.  
Queue shown is maximum after two cycles.
- dr Defacto Right Lane. Recode with 1 though lane as a right lane.

# HCM Unsignalized Intersection Capacity Analysis

## 102: SW Woodhaven Dr & SW Sunset Blvd

02/05/2019

												
Movement	EBL	EBT	EBR	WBL	WBT	WBR	NBL	NBT	NBR	SBL	SBT	SBR
Lane Configurations												
Traffic Volume (veh/h)	121	387	26	5	414	72	12	0	1	36	1	64
Future Volume (Veh/h)	121	387	26	5	414	72	12	0	1	36	1	64
Sign Control		Free			Free			Stop			Stop	
Grade		-1%			1%			-2%			0%	
Peak Hour Factor	0.92	0.92	0.92	0.92	0.92	0.92	0.92	0.92	0.92	0.92	0.92	0.92
Hourly flow rate (vph)	132	421	28	5	450	78	13	0	1	39	1	70
Pedestrians												
Lane Width (ft)												
Walking Speed (ft/s)												
Percent Blockage												
Right turn flare (veh)												
Median type												
		None			None							
Median storage (veh)												
Upstream signal (ft)												
		648										
pX, platoon unblocked												
vC, conflicting volume	528			449			1216	1223	421	1185	1212	489
vC1, stage 1 conf vol												
vC2, stage 2 conf vol												
vCu, unblocked vol	528			449			1216	1223	421	1185	1212	489
tC, single (s)	4.1			4.1			7.1	6.5	6.2	7.1	6.5	6.2
tC, 2 stage (s)												
tF (s)	2.2			2.2			3.5	4.0	3.3	3.5	4.0	3.3
p0 queue free %	87			100			90	100	100	74	99	88
cM capacity (veh/h)	1044			1122			126	158	637	150	160	579
Direction, Lane #	EB 1	EB 2	EB 3	WB 1	WB 2	NB 1	SB 1					
Volume Total	132	421	28	5	528	14	110					
Volume Left	132	0	0	5	0	13	39					
Volume Right	0	0	28	0	78	1	70					
cSH	1044	1700	1700	1122	1700	133	285					
Volume to Capacity	0.13	0.25	0.02	0.00	0.31	0.10	0.39					
Queue Length 95th (ft)	11	0	0	0	0	9	44					
Control Delay (s)	8.9	0.0	0.0	8.2	0.0	35.1	25.4					
Lane LOS	A			A		E	D					
Approach Delay (s)	2.0			0.1		35.1	25.4					
Approach LOS						E	D					
Intersection Summary												
Average Delay			3.6									
Intersection Capacity Utilization			48.4%			ICU Level of Service			A			
Analysis Period (min)			15									

HCM Unsignalized Intersection Capacity Analysis  
 103: SW Timbrel Ln & SW Sunset Blvd

02/05/2019



Movement	EBT	EBR	WBL	WBT	NBL	NBR
Lane Configurations	↻		↻	↻	↻	
Traffic Volume (veh/h)	314	110	63	403	89	37
Future Volume (Veh/h)	314	110	63	403	89	37
Sign Control	Free			Free	Stop	
Grade	-1%			1%	0%	
Peak Hour Factor	0.91	0.91	0.91	0.91	0.91	0.91
Hourly flow rate (vph)	345	121	69	443	98	41
Pedestrians				1		
Lane Width (ft)				12.0		
Walking Speed (ft/s)				3.5		
Percent Blockage				0		
Right turn flare (veh)						
Median type	None			None		
Median storage (veh)						
Upstream signal (ft)	1264					
pX, platoon unblocked						
vC, conflicting volume			466		986	406
vC1, stage 1 conf vol						
vC2, stage 2 conf vol						
vCu, unblocked vol			466		986	406
tC, single (s)			4.1		6.4	6.2
tC, 2 stage (s)						
tF (s)			2.2		3.5	3.3
p0 queue free %			94		62	94
cM capacity (veh/h)			1090		257	642

Direction, Lane #	EB 1	WB 1	WB 2	NB 1
Volume Total	466	69	443	139
Volume Left	0	69	0	98
Volume Right	121	0	0	41
cSH	1700	1090	1700	312
Volume to Capacity	0.27	0.06	0.26	0.44
Queue Length 95th (ft)	0	5	0	55
Control Delay (s)	0.0	8.5	0.0	25.4
Lane LOS		A		D
Approach Delay (s)	0.0	1.1		25.4
Approach LOS				D

Intersection Summary			
Average Delay		3.7	
Intersection Capacity Utilization	44.1%		ICU Level of Service A
Analysis Period (min)	15		

**Intersection**

Intersection Delay, s/veh	33.1
Intersection LOS	D

Movement	EBL	EBT	EBR	WBL	WBT	WBR	NBL	NBT	NBR	SBL	SBT	SBR
Lane Configurations	↔	↔		↔	↔		↔	↔		↔	↔	
Traffic Vol, veh/h	27	133	134	34	103	52	99	226	29	69	368	41
Future Vol, veh/h	27	133	134	34	103	52	99	226	29	69	368	41
Peak Hour Factor	0.89	0.89	0.89	0.89	0.89	0.89	0.89	0.89	0.89	0.89	0.89	0.89
Heavy Vehicles, %	0	2	1	3	0	2	0	3	0	2	1	3
Mvmt Flow	30	149	151	38	116	58	111	254	33	78	413	46
Number of Lanes	1	1	0	1	1	0	1	1	0	1	1	0

Approach	EB	WB	NB	SB
Opposing Approach	WB	EB	SB	NB
Opposing Lanes	2	2	2	2
Conflicting Approach Left	SB	NB	EB	WB
Conflicting Lanes Left	2	2	2	2
Conflicting Approach Right	NB	SB	WB	EB
Conflicting Lanes Right	2	2	2	2
HCM Control Delay	23.8	16.2	20.8	54.7
HCM LOS	C	C	C	F

Lane	NBLn1	NBLn2	EBLn1	EBLn2	WBLn1	WBLn2	SBLn1	SBLn2
Vol Left, %	100%	0%	100%	0%	100%	0%	100%	0%
Vol Thru, %	0%	89%	0%	50%	0%	66%	0%	90%
Vol Right, %	0%	11%	0%	50%	0%	34%	0%	10%
Sign Control	Stop	Stop	Stop	Stop	Stop	Stop	Stop	Stop
Traffic Vol by Lane	99	255	27	267	34	155	69	409
LT Vol	99	0	27	0	34	0	69	0
Through Vol	0	226	0	133	0	103	0	368
RT Vol	0	29	0	134	0	52	0	41
Lane Flow Rate	111	287	30	300	38	174	78	460
Geometry Grp	7	7	7	7	7	7	7	7
Degree of Util (X)	0.262	0.631	0.074	0.662	0.098	0.408	0.177	0.971
Departure Headway (Hd)	8.478	7.931	8.791	7.945	9.246	8.429	8.211	7.607
Convergence, Y/N	Yes	Yes	Yes	Yes	Yes	Yes	Yes	Yes
Cap	424	456	407	456	387	427	440	478
Service Time	6.236	5.689	6.546	5.699	7.011	6.192	5.911	5.307
HCM Lane V/C Ratio	0.262	0.629	0.074	0.658	0.098	0.407	0.177	0.962
HCM Control Delay	14.2	23.4	12.3	25	13	16.9	12.7	61.8
HCM Lane LOS	B	C	B	C	B	C	B	F
HCM 95th-tile Q	1	4.3	0.2	4.7	0.3	1.9	0.6	12.3

Intersection	
Intersection Delay, s/veh	28.9
Intersection LOS	D

Movement	EBL	EBT	EBR	WBL	WBT	WBR	NBL	NBT	NBR	SBL	SBT	SBR
Lane Configurations												
Traffic Vol, veh/h	105	14	165	1	21	16	313	143	6	32	149	273
Future Vol, veh/h	105	14	165	1	21	16	313	143	6	32	149	273
Peak Hour Factor	0.90	0.90	0.90	0.90	0.90	0.90	0.90	0.90	0.90	0.90	0.90	0.90
Heavy Vehicles, %	0	0	5	100	0	0	2	1	0	0	2	2
Mvmt Flow	117	16	183	1	23	18	348	159	7	36	166	303
Number of Lanes	1	1	0	0	1	0	0	1	0	0	1	0

Approach	EB	WB	NB	SB
Opposing Approach	WB	EB	SB	NB
Opposing Lanes	1	2	1	1
Conflicting Approach Left	SB	NB	EB	WB
Conflicting Lanes Left	1	1	2	1
Conflicting Approach Right	NB	SB	WB	EB
Conflicting Lanes Right	1	1	1	2
HCM Control Delay	13.7	13.8	39.6	28.8
HCM LOS	B	B	E	D

Lane	NBLn1	EBLn1	EBLn2	WBLn1	SBLn1
Vol Left, %	68%	100%	0%	3%	7%
Vol Thru, %	31%	0%	8%	55%	33%
Vol Right, %	1%	0%	92%	42%	60%
Sign Control	Stop	Stop	Stop	Stop	Stop
Traffic Vol by Lane	462	105	179	38	454
LT Vol	313	105	0	1	32
Through Vol	143	0	14	21	149
RT Vol	6	0	165	16	273
Lane Flow Rate	513	117	199	42	504
Geometry Grp	2	7	7	5	2
Degree of Util (X)	0.885	0.26	0.378	0.111	0.809
Departure Headway (Hd)	6.204	8.017	6.838	9.5	5.775
Convergence, Y/N	Yes	Yes	Yes	Yes	Yes
Cap	585	448	525	376	626
Service Time	4.246	5.768	4.589	7.584	3.817
HCM Lane V/C Ratio	0.877	0.261	0.379	0.112	0.805
HCM Control Delay	39.6	13.6	13.7	13.8	28.8
HCM Lane LOS	E	B	B	B	D
HCM 95th-tile Q	10.3	1	1.7	0.4	8.2

HCM Unsignalized Intersection Capacity Analysis  
 106: SW Pacific Hwy & SW Chapman Rd

02/05/2019



Movement	EBL	EBT	EBR	WBL	WBT	WBR	NBU	NBL	NBT	NBR	SBU	SBL
Lane Configurations		↔			↔			↔	↕			↔
Traffic Volume (veh/h)	20	7	12	40	5	30	1	8	1368	46	2	24
Future Volume (Veh/h)	20	7	12	40	5	30	1	8	1368	46	2	24
Sign Control		Stop			Stop				Free			
Grade		0%			0%				0%			
Peak Hour Factor	0.96	0.96	0.96	0.96	0.96	0.96	0.96	0.96	0.96	0.96	0.96	0.96
Hourly flow rate (vph)	21	7	13	42	5	31	0	8	1425	48	0	25
Pedestrians												
Lane Width (ft)												
Walking Speed (ft/s)												
Percent Blockage												
Right turn flare (veh)												
Median type									Raised			
Median storage (veh)									2			
Upstream signal (ft)												
pX, platoon unblocked							0.00				0.00	
vC, conflicting volume	2997	3724	1092	2624	3744	736	0	2229			0	1473
vC1, stage 1 conf vol	2235	2235		1465	1465							
vC2, stage 2 conf vol	762	1489		1159	2279							
vCu, unblocked vol	2997	3724	1092	2624	3744	736	0	2229			0	1473
tC, single (s)	7.6	6.5	6.9	7.6	6.5	6.9	0.0	4.1			0.0	4.1
tC, 2 stage (s)	6.6	5.5		6.6	5.5							
tF (s)	3.5	4.0	3.3	3.5	4.0	3.3	0.0	2.2			0.0	2.2
p0 queue free %	45	89	94	56	91	92	0	97			0	95
cM capacity (veh/h)	38	65	213	95	58	366	0	237			0	464

Direction, Lane #	EB 1	WB 1	NB 1	NB 2	NB 3	SB 1	SB 2	SB 3	SB 4
Volume Total	41	78	8	950	523	25	1092	1092	44
Volume Left	21	42	8	0	0	25	0	0	0
Volume Right	13	31	0	0	48	0	0	0	44
cSH	57	127	237	1700	1700	464	1700	1700	1700
Volume to Capacity	0.72	0.61	0.03	0.56	0.31	0.05	0.64	0.64	0.03
Queue Length 95th (ft)	76	79	3	0	0	4	0	0	0
Control Delay (s)	161.7	70.2	20.7	0.0	0.0	13.2	0.0	0.0	0.0
Lane LOS	F	F	C			B			
Approach Delay (s)	161.7	70.2	0.1			0.1			
Approach LOS	F	F							

Intersection Summary		
Average Delay		3.3
Intersection Capacity Utilization	70.1%	ICU Level of Service C
Analysis Period (min)		15

HCM Unsignalized Intersection Capacity Analysis  
 106: SW Pacific Hwy & SW Chapman Rd

02/05/2019



Movement	SBT	SBR
Lane Configurations	↑↑	↑
Traffic Volume (veh/h)	2098	42
Future Volume (Veh/h)	2098	42
Sign Control	Free	
Grade	0%	
Peak Hour Factor	0.96	0.96
Hourly flow rate (vph)	2185	44
Pedestrians		
Lane Width (ft)		
Walking Speed (ft/s)		
Percent Blockage		
Right turn flare (veh)		
Median type	Raised	
Median storage veh)	2	
Upstream signal (ft)		
pX, platoon unblocked		
vC, conflicting volume		
vC1, stage 1 conf vol		
vC2, stage 2 conf vol		
vCu, unblocked vol		
tC, single (s)		
tC, 2 stage (s)		
tF (s)		
p0 queue free %		
cM capacity (veh/h)		
Direction, Lane #		



HCM Unsignalized Intersection Capacity Analysis  
 107: SW Old Hwy 99W & SW Brookman Rd

02/05/2019



Movement	EBL	EBT	EBR	WBL	WBT	WBR	NBL	NBT	NBR	SBL	SBT	SBR
Lane Configurations		↕			↕			↕			↕	
Traffic Volume (veh/h)	10	60	1	1	70	2	1	1	2	1	1	1
Future Volume (Veh/h)	10	60	1	1	70	2	1	1	2	1	1	1
Sign Control		Free			Free			Stop			Stop	
Grade		0%			2%			2%			-2%	
Peak Hour Factor	0.82	0.82	0.82	0.82	0.82	0.82	0.82	0.82	0.82	0.82	0.82	0.82
Hourly flow rate (vph)	12	73	1	1	85	2	1	1	2	1	1	1
Pedestrians												
Lane Width (ft)												
Walking Speed (ft/s)												
Percent Blockage												
Right turn flare (veh)												
Median type		None			None							
Median storage (veh)												
Upstream signal (ft)												
pX, platoon unblocked												
vC, conflicting volume	87			74			187	186	74	188	186	86
vC1, stage 1 conf vol												
vC2, stage 2 conf vol												
vCu, unblocked vol	87			74			187	186	74	188	186	86
tC, single (s)	4.1			4.1			7.1	6.5	6.2	7.1	6.5	6.2
tC, 2 stage (s)												
tF (s)	2.2			2.2			3.5	4.0	3.3	3.5	4.0	3.3
p0 queue free %	99			100			100	100	100	100	100	100
cM capacity (veh/h)	1522			1538			771	705	994	769	706	978
<b>Direction, Lane #</b>	<b>EB 1</b>	<b>WB 1</b>	<b>NB 1</b>	<b>SB 1</b>								
Volume Total	86	88	4	3								
Volume Left	12	1	1	1								
Volume Right	1	2	2	1								
cSH	1522	1538	846	803								
Volume to Capacity	0.01	0.00	0.00	0.00								
Queue Length 95th (ft)	1	0	0	0								
Control Delay (s)	1.1	0.1	9.3	9.5								
Lane LOS	A	A	A	A								
Approach Delay (s)	1.1	0.1	9.3	9.5								
Approach LOS			A	A								
<b>Intersection Summary</b>												
Average Delay			0.9									
Intersection Capacity Utilization			19.5%		ICU Level of Service				A			
Analysis Period (min)			15									

HCM Unsignalized Intersection Capacity Analysis  
 108: SW Middleton Rd & SW Brookman Rd

02/05/2019



Movement	EBL	EBT	EBR	WBL	WBT	WBR	NBL	NBT	NBR	SBL	SBT	SBR
Lane Configurations		↕			↕			↕			↕	
Traffic Volume (veh/h)	10	42	16	12	50	3	15	6	8	2	10	4
Future Volume (Veh/h)	10	42	16	12	50	3	15	6	8	2	10	4
Sign Control		Stop			Stop			Free			Free	
Grade		-1%			1%			-2%			0%	
Peak Hour Factor	0.74	0.74	0.74	0.74	0.74	0.74	0.74	0.74	0.74	0.74	0.74	0.74
Hourly flow rate (vph)	14	57	22	16	68	4	20	8	11	3	14	5
Pedestrians		1			1						1	
Lane Width (ft)		12.0			12.0						12.0	
Walking Speed (ft/s)		3.5			3.5						3.5	
Percent Blockage		0			0						0	
Right turn flare (veh)												
Median type								None			None	
Median storage (veh)												
Upstream signal (ft)												
pX, platoon unblocked												
vC, conflicting volume	116	84	18	128	80	16	20			20		
vC1, stage 1 conf vol												
vC2, stage 2 conf vol												
vCu, unblocked vol	116	84	18	128	80	16	20			20		
tC, single (s)	7.1	6.5	6.2	7.2	6.5	6.2	4.2			4.1		
tC, 2 stage (s)												
tF (s)	3.5	4.0	3.3	3.6	4.0	3.3	2.3			2.2		
p0 queue free %	98	93	98	98	91	100	99			100		
cM capacity (veh/h)	794	797	1066	758	800	1068	1514			1608		
<b>Direction, Lane #</b>	<b>EB 1</b>	<b>WB 1</b>	<b>NB 1</b>	<b>SB 1</b>								
Volume Total	93	88	39	22								
Volume Left	14	16	20	3								
Volume Right	22	4	11	5								
cSH	847	801	1514	1608								
Volume to Capacity	0.11	0.11	0.01	0.00								
Queue Length 95th (ft)	9	9	1	0								
Control Delay (s)	9.8	10.0	3.8	1.0								
Lane LOS	A	B	A	A								
Approach Delay (s)	9.8	10.0	3.8	1.0								
Approach LOS	A	B										
<b>Intersection Summary</b>												
Average Delay			8.1									
Intersection Capacity Utilization			17.1%		ICU Level of Service				A			
Analysis Period (min)			15									

HCM Unsignalized Intersection Capacity Analysis  
 109: SW Oberst Rd & SW Brookman Rd

02/05/2019



Movement	EBT	EBR	WBL	WBT	NBL	NBR
Lane Configurations	→			←	↘	↙
Traffic Volume (veh/h)	51	0	4	67	4	4
Future Volume (Veh/h)	51	0	4	67	4	4
Sign Control	Free			Free	Stop	
Grade	-3%			2%	1%	
Peak Hour Factor	0.69	0.69	0.69	0.69	0.69	0.69
Hourly flow rate (vph)	74	0	6	97	6	6
Pedestrians						
Lane Width (ft)						
Walking Speed (ft/s)						
Percent Blockage						
Right turn flare (veh)						
Median type	None			None		
Median storage (veh)						
Upstream signal (ft)						
pX, platoon unblocked						
vC, conflicting volume			74		183	74
vC1, stage 1 conf vol						
vC2, stage 2 conf vol						
vCu, unblocked vol			74		183	74
tC, single (s)			4.1		6.7	6.5
tC, 2 stage (s)						
tF (s)			2.2		3.7	3.5
p0 queue free %			100		99	99
cM capacity (veh/h)			1538		754	927
Direction, Lane #	EB 1	WB 1	NB 1			
Volume Total	74	103	12			
Volume Left	0	6	6			
Volume Right	0	0	6			
cSH	1700	1538	831			
Volume to Capacity	0.04	0.00	0.01			
Queue Length 95th (ft)	0	0	1			
Control Delay (s)	0.0	0.5	9.4			
Lane LOS		A	A			
Approach Delay (s)	0.0	0.5	9.4			
Approach LOS			A			
Intersection Summary						
Average Delay			0.8			
Intersection Capacity Utilization			16.8%	ICU Level of Service	A	
Analysis Period (min)			15			

# HCM Unsignalized Intersection Capacity Analysis

## 110: SW Ladd Hill Rd & SW Brookman Rd

02/05/2019



Movement	EBL	EBR	NBL	NBT	SBT	SBR
Lane Configurations						
Traffic Volume (veh/h)	35	16	10	86	95	55
Future Volume (Veh/h)	35	16	10	86	95	55
Sign Control	Stop			Free	Free	
Grade	2%			-1%	0%	
Peak Hour Factor	0.78	0.78	0.78	0.78	0.78	0.78
Hourly flow rate (vph)	45	21	13	110	122	71
<b>Pedestrians</b>						
Lane Width (ft)						
Walking Speed (ft/s)						
Percent Blockage						
Right turn flare (veh)						
Median type				None	None	
Median storage (veh)						
Upstream signal (ft)						
pX, platoon unblocked						
vC, conflicting volume	294	158	193			
vC1, stage 1 conf vol						
vC2, stage 2 conf vol						
vCu, unblocked vol	294	158	193			
tC, single (s)	6.4	6.3	4.1			
tC, 2 stage (s)						
tF (s)	3.5	3.4	2.2			
p0 queue free %	93	98	99			
cM capacity (veh/h)	689	875	1392			
<b>Direction, Lane #</b>	<b>EB 1</b>	<b>NB 1</b>	<b>SB 1</b>			
Volume Total	66	123	193			
Volume Left	45	13	0			
Volume Right	21	0	71			
cSH	739	1392	1700			
Volume to Capacity	0.09	0.01	0.11			
Queue Length 95th (ft)	7	1	0			
Control Delay (s)	10.4	0.9	0.0			
Lane LOS	B	A				
Approach Delay (s)	10.4	0.9	0.0			
Approach LOS	B					
<b>Intersection Summary</b>						
Average Delay			2.1			
Intersection Capacity Utilization			22.9%	ICU Level of Service	A	
Analysis Period (min)			15			

# Queues

## 101: SW Pacific Hwy & SW Elwert Rd/SW Sunset Blvd

02/05/2019



Lane Group	EBL	EBT	WBL	WBT	NBL	NBT	NBR	SBL	SBT	SBR
Lane Group Flow (vph)	138	545	114	638	353	1694	118	137	806	204
v/c Ratio	0.89	0.66	0.79	0.86	0.83	0.99	0.15	0.58	0.56	0.26
Control Delay	117.7	42.0	105.6	66.2	84.4	58.1	8.4	81.1	35.0	4.2
Queue Delay	0.0	0.0	0.0	0.0	0.0	0.0	0.0	0.0	0.0	0.0
Total Delay	117.7	42.0	105.6	66.2	84.4	58.1	8.4	81.1	35.0	4.2
Queue Length 50th (ft)	148	189	120	307	190	~996	19	73	340	0
Queue Length 95th (ft)	#287	256	#227	385	#257	#1135	57	112	408	51
Internal Link Dist (ft)		263		568		888			476	
Turn Bay Length (ft)					320		150	210		300
Base Capacity (vph)	155	891	152	829	458	1717	810	264	1451	780
Starvation Cap Reductn	0	0	0	0	0	0	0	0	0	0
Spillback Cap Reductn	0	0	0	0	0	0	0	0	0	0
Storage Cap Reductn	0	0	0	0	0	0	0	0	0	0
Reduced v/c Ratio	0.89	0.61	0.75	0.77	0.77	0.99	0.15	0.52	0.56	0.26

### Intersection Summary

~ Volume exceeds capacity, queue is theoretically infinite.

Queue shown is maximum after two cycles.

# 95th percentile volume exceeds capacity, queue may be longer.

Queue shown is maximum after two cycles.

HCM Unsignalized Intersection Capacity Analysis  
 102: SW Woodhaven Dr & SW Sunset Blvd

02/05/2019



Movement	EBL	EBT	EBR	WBL	WBT	WBR	NBL	NBT	NBR	SBL	SBT	SBR
Lane Configurations												
Traffic Volume (veh/h)	55	339	74	7	562	91	20	15	11	29	47	119
Future Volume (Veh/h)	55	339	74	7	562	91	20	15	11	29	47	119
Sign Control		Free			Free			Stop			Stop	
Grade		-1%			1%			-2%			0%	
Peak Hour Factor	0.80	0.80	0.80	0.80	0.80	0.80	0.80	0.80	0.80	0.80	0.80	0.80
Hourly flow rate (vph)	69	424	93	9	703	114	25	19	14	36	59	149
Pedestrians					5							3
Lane Width (ft)					12.0							12.0
Walking Speed (ft/s)					3.5							3.5
Percent Blockage					0							0
Right turn flare (veh)												
Median type		None			None							
Median storage (veh)												
Upstream signal (ft)		648										
pX, platoon unblocked				0.91			0.91	0.91	0.91	0.91	0.91	
vC, conflicting volume	820			517			1462	1400	429	1372	1436	763
vC1, stage 1 conf vol												
vC2, stage 2 conf vol												
vCu, unblocked vol	820			422			1458	1390	325	1359	1430	763
tC, single (s)	4.2			4.2			7.1	6.5	6.2	7.2	6.5	6.2
tC, 2 stage (s)												
tF (s)	2.3			2.3			3.5	4.0	3.3	3.6	4.0	3.3
p0 queue free %	91			99			27	84	98	59	47	63
cM capacity (veh/h)	781			981			34	118	654	88	112	406
<b>Direction, Lane #</b>	<b>EB 1</b>	<b>EB 2</b>	<b>EB 3</b>	<b>WB 1</b>	<b>WB 2</b>	<b>NB 1</b>	<b>SB 1</b>					
Volume Total	69	424	93	9	817	58	244					
Volume Left	69	0	0	9	0	25	36					
Volume Right	0	0	93	0	114	14	149					
cSH	781	1700	1700	981	1700	63	187					
Volume to Capacity	0.09	0.25	0.05	0.01	0.48	0.92	1.30					
Queue Length 95th (ft)	7	0	0	1	0	109	344					
Control Delay (s)	10.1	0.0	0.0	8.7	0.0	197.0	218.8					
Lane LOS	B			A		F	F					
Approach Delay (s)	1.2			0.1		197.0	218.8					
Approach LOS						F	F					
<b>Intersection Summary</b>												
Average Delay			38.3									
Intersection Capacity Utilization			60.4%		ICU Level of Service				B			
Analysis Period (min)			15									

HCM Unsignalized Intersection Capacity Analysis  
 103: SW Timbrel Ln & SW Sunset Blvd

02/05/2019



Movement	EBT	EBR	WBL	WBT	NBL	NBR
Lane Configurations	↻		↻	↻	↻	
Traffic Volume (veh/h)	303	75	75	462	198	48
Future Volume (Veh/h)	303	75	75	462	198	48
Sign Control	Free			Free	Stop	
Grade	-1%			1%	0%	
Peak Hour Factor	0.84	0.84	0.84	0.84	0.84	0.84
Hourly flow rate (vph)	361	89	89	550	236	57
Pedestrians				21	1	
Lane Width (ft)				12.0	12.0	
Walking Speed (ft/s)				3.5	3.5	
Percent Blockage				2	0	
Right turn flare (veh)						
Median type	None			None		
Median storage (veh)						
Upstream signal (ft)	1264					
pX, platoon unblocked						
vC, conflicting volume			451	1134		428
vC1, stage 1 conf vol						
vC2, stage 2 conf vol						
vCu, unblocked vol			451	1134		428
tC, single (s)			4.2	6.4		6.3
tC, 2 stage (s)						
tF (s)			2.3	3.5		3.4
p0 queue free %			92	0		91
cM capacity (veh/h)			1088	203		604

Direction, Lane #	EB 1	WB 1	WB 2	NB 1
Volume Total	450	89	550	293
Volume Left	0	89	0	236
Volume Right	89	0	0	57
cSH	1700	1088	1700	233
Volume to Capacity	0.26	0.08	0.32	1.26
Queue Length 95th (ft)	0	7	0	373
Control Delay (s)	0.0	8.6	0.0	189.1
Lane LOS	A		F	
Approach Delay (s)	0.0	1.2	189.1	
Approach LOS	F			

Intersection Summary			
Average Delay	40.6		
Intersection Capacity Utilization	49.0%	ICU Level of Service	A
Analysis Period (min)	15		

Intersection

Intersection Delay, s/veh	22.6
Intersection LOS	C

Movement	EBL	EBT	EBR	WBL	WBT	WBR	NBL	NBT	NBR	SBL	SBT	SBR
Lane Configurations	↶	↷		↶	↷		↶	↷		↶	↷	
Traffic Vol, veh/h	112	311	39	37	265	32	89	143	85	30	42	107
Future Vol, veh/h	112	311	39	37	265	32	89	143	85	30	42	107
Peak Hour Factor	0.90	0.90	0.90	0.90	0.90	0.90	0.90	0.90	0.90	0.90	0.90	0.90
Heavy Vehicles, %	5	2	0	13	2	0	3	2	6	0	5	2
Mvmt Flow	124	346	43	41	294	36	99	159	94	33	47	119
Number of Lanes	1	1	0	1	1	0	1	1	0	1	1	0

Approach	EB	WB	NB	SB
Opposing Approach	WB	EB	SB	NB
Opposing Lanes	2	2	2	2
Conflicting Approach Left	SB	NB	EB	WB
Conflicting Lanes Left	2	2	2	2
Conflicting Approach Right	NB	SB	WB	EB
Conflicting Lanes Right	2	2	2	2
HCM Control Delay	28	24.3	17.6	14.6
HCM LOS	D	C	C	B

Lane	NBLn1	NBLn2	EBLn1	EBLn2	WBLn1	WBLn2	SBLn1	SBLn2
Vol Left, %	100%	0%	100%	0%	100%	0%	100%	0%
Vol Thru, %	0%	63%	0%	89%	0%	89%	0%	28%
Vol Right, %	0%	37%	0%	11%	0%	11%	0%	72%
Sign Control	Stop	Stop	Stop	Stop	Stop	Stop	Stop	Stop
Traffic Vol by Lane	89	228	112	350	37	297	30	149
LT Vol	89	0	112	0	37	0	30	0
Through Vol	0	143	0	311	0	265	0	42
RT Vol	0	85	0	39	0	32	0	107
Lane Flow Rate	99	253	124	389	41	330	33	166
Geometry Grp	7	7	7	7	7	7	7	7
Degree of Util (X)	0.233	0.539	0.275	0.79	0.095	0.692	0.082	0.362
Departure Headway (Hd)	8.466	7.664	7.963	7.317	8.338	7.554	8.832	7.881
Convergence, Y/N	Yes	Yes	Yes	Yes	Yes	Yes	Yes	Yes
Cap	422	469	449	494	428	475	404	454
Service Time	6.246	5.443	5.741	5.095	6.119	5.334	6.624	5.672
HCM Lane V/C Ratio	0.235	0.539	0.276	0.787	0.096	0.695	0.082	0.366
HCM Control Delay	13.8	19.1	13.8	32.6	12	25.8	12.4	15.1
HCM Lane LOS	B	C	B	D	B	D	B	C
HCM 95th-tile Q	0.9	3.1	1.1	7.2	0.3	5.2	0.3	1.6



**Intersection**

Intersection Delay, s/veh	15.6
Intersection LOS	C

Movement	EBL	EBT	EBR	WBL	WBT	WBR	NBL	NBT	NBR	SBL	SBT	SBR
Lane Configurations												
Traffic Vol, veh/h	280	9	227	5	23	24	141	141	3	5	116	105
Future Vol, veh/h	280	9	227	5	23	24	141	141	3	5	116	105
Peak Hour Factor	0.91	0.91	0.91	0.91	0.91	0.91	0.91	0.91	0.91	0.91	0.91	0.91
Heavy Vehicles, %	3	14	4	20	5	0	7	5	67	20	5	8
Mvmt Flow	308	10	249	5	25	26	155	155	3	5	127	115
Number of Lanes	1	1	0	0	1	0	0	1	0	0	1	0

Approach	EB	WB	NB	SB
Opposing Approach	WB	EB	SB	NB
Opposing Lanes	1	2	1	1
Conflicting Approach Left	SB	NB	EB	WB
Conflicting Lanes Left	1	1	2	1
Conflicting Approach Right	NB	SB	WB	EB
Conflicting Lanes Right	1	1	1	2
HCM Control Delay	16.3	10.8	16.6	14
HCM LOS	C	B	C	B

Lane	NBLn1	EBLn1	EBLn2	WBLn1	SBLn1
Vol Left, %	49%	100%	0%	10%	2%
Vol Thru, %	49%	0%	4%	44%	51%
Vol Right, %	1%	0%	96%	46%	46%
Sign Control	Stop	Stop	Stop	Stop	Stop
Traffic Vol by Lane	285	280	236	52	226
LT Vol	141	280	0	5	5
Through Vol	141	0	9	23	116
RT Vol	3	0	227	24	105
Lane Flow Rate	313	308	259	57	248
Geometry Grp	2	7	7	5	2
Degree of Util (X)	0.543	0.589	0.424	0.111	0.43
Departure Headway (Hd)	6.243	6.892	5.889	6.976	6.237
Convergence, Y/N	Yes	Yes	Yes	Yes	Yes
Cap	573	523	609	517	574
Service Time	4.317	4.66	3.656	4.976	4.317
HCM Lane V/C Ratio	0.546	0.589	0.425	0.11	0.432
HCM Control Delay	16.6	19.1	13	10.8	14
HCM Lane LOS	C	C	B	B	B
HCM 95th-tile Q	3.2	3.8	2.1	0.4	2.1

HCM Unsignalized Intersection Capacity Analysis  
 106: SW Pacific Hwy & SW Chapman Rd

02/05/2019

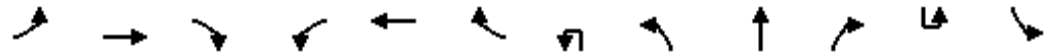

Movement	EBL	EBT	EBR	WBL	WBT	WBR	NBU	NBL	NBT	NBR	SBU	SBL
Lane Configurations		↕			↕			↕	↕			↕
Traffic Volume (veh/h)	30	3	2	47	3	93	4	8	1914	92	3	38
Future Volume (Veh/h)	30	3	2	47	3	93	4	8	1914	92	3	38
Sign Control		Stop			Stop				Free			
Grade		0%			0%				0%			
Peak Hour Factor	0.96	0.96	0.96	0.96	0.96	0.96	0.96	0.96	0.96	0.96	0.96	0.96
Hourly flow rate (vph)	31	3	2	49	3	97	0	8	1994	96	0	40
Pedestrians												
Lane Width (ft)												
Walking Speed (ft/s)												
Percent Blockage												
Right turn flare (veh)												
Median type									Raised			
Median storage (veh)									2			
Upstream signal (ft)												
pX, platoon unblocked							0.00				0.00	
vC, conflicting volume	2344	3338	576	2718	3307	1045	0	1169			0	2090
vC1, stage 1 conf vol	1232	1232		2058	2058							
vC2, stage 2 conf vol	1112	2106		660	1249							
vCu, unblocked vol	2344	3338	576	2718	3307	1045	0	1169			0	2090
tC, single (s)	7.7	6.5	6.9	7.6	6.5	7.2	0.0	4.1			0.0	4.1
tC, 2 stage (s)	6.7	5.5		6.6	5.5							
tF (s)	3.6	4.0	3.3	3.5	4.0	3.4	0.0	2.2			0.0	2.2
p0 queue free %	47	94	100	5	96	53	0	99			0	85
cM capacity (veh/h)	58	49	466	52	84	207	0	605			0	268
<b>Direction, Lane #</b>	<b>EB 1</b>	<b>WB 1</b>	<b>NB 1</b>	<b>NB 2</b>	<b>NB 3</b>	<b>SB 1</b>	<b>SB 2</b>	<b>SB 3</b>	<b>SB 4</b>			
Volume Total	36	149	8	1329	761	40	576	576	17			
Volume Left	31	49	8	0	0	40	0	0	0			
Volume Right	2	97	0	0	96	0	0	0	17			
cSH	60	103	605	1700	1700	268	1700	1700	1700			
Volume to Capacity	0.60	1.45	0.01	0.78	0.45	0.15	0.34	0.34	0.01			
Queue Length 95th (ft)	62	273	1	0	0	13	0	0	0			
Control Delay (s)	130.5	323.8	11.0	0.0	0.0	20.8	0.0	0.0	0.0			
Lane LOS	F	F	B			C						
Approach Delay (s)	130.5	323.8	0.0			0.7						
Approach LOS	F	F										
<b>Intersection Summary</b>												
Average Delay			15.4									
Intersection Capacity Utilization			70.5%		ICU Level of Service				C			
Analysis Period (min)			15									

HCM Unsignalized Intersection Capacity Analysis  
 106: SW Pacific Hwy & SW Chapman Rd

02/05/2019



Movement	SBT	SBR
Lane Configurations	↑↑	↑
Traffic Volume (veh/h)	1106	16
Future Volume (Veh/h)	1106	16
Sign Control	Free	
Grade	0%	
Peak Hour Factor	0.96	0.96
Hourly flow rate (vph)	1152	17
Pedestrians		
Lane Width (ft)		
Walking Speed (ft/s)		
Percent Blockage		
Right turn flare (veh)		
Median type	Raised	
Median storage veh)	2	
Upstream signal (ft)		
pX, platoon unblocked		
vC, conflicting volume		
vC1, stage 1 conf vol		
vC2, stage 2 conf vol		
vCu, unblocked vol		
tC, single (s)		
tC, 2 stage (s)		
tF (s)		
p0 queue free %		
cM capacity (veh/h)		
Direction, Lane #		

HCM Unsignalized Intersection Capacity Analysis  
 107: SW Old Hwy 99W & SW Brookman Rd

02/05/2019



Movement	EBL	EBT	EBR	WBL	WBT	WBR	NBL	NBT	NBR	SBL	SBT	SBR
Lane Configurations		↕			↕			↕			↕	
Traffic Volume (veh/h)	11	120	2	0	122	3	3	2	2	8	3	15
Future Volume (Veh/h)	11	120	2	0	122	3	3	2	2	8	3	15
Sign Control		Free			Free			Stop			Stop	
Grade		0%			2%			2%			-2%	
Peak Hour Factor	0.69	0.69	0.69	0.69	0.69	0.69	0.69	0.69	0.69	0.69	0.69	0.69
Hourly flow rate (vph)	16	174	3	0	177	4	4	3	3	12	4	22
Pedestrians												
Lane Width (ft)												
Walking Speed (ft/s)												
Percent Blockage												
Right turn flare (veh)												
Median type		None			None							
Median storage (veh)												
Upstream signal (ft)												
pX, platoon unblocked												
vC, conflicting volume	181			177			410	388	176	391	388	179
vC1, stage 1 conf vol												
vC2, stage 2 conf vol												
vCu, unblocked vol	181			177			410	388	176	391	388	179
tC, single (s)	4.1			4.1			7.6	7.0	6.2	7.1	6.5	6.4
tC, 2 stage (s)												
tF (s)	2.2			2.2			4.0	4.5	3.3	3.5	4.0	3.5
p0 queue free %	99			100			99	99	100	98	99	97
cM capacity (veh/h)	1407			1411			456	473	873	562	544	817
Direction, Lane #												
	EB 1	WB 1	NB 1	SB 1								
Volume Total	193	181	10	38								
Volume Left	16	0	4	12								
Volume Right	3	4	3	22								
cSH	1407	1411	539	683								
Volume to Capacity	0.01	0.00	0.02	0.06								
Queue Length 95th (ft)	1	0	1	4								
Control Delay (s)	0.7	0.0	11.8	10.6								
Lane LOS	A		B	B								
Approach Delay (s)	0.7	0.0	11.8	10.6								
Approach LOS			B	B								
Intersection Summary												
Average Delay			1.6									
Intersection Capacity Utilization			25.6%		ICU Level of Service				A			
Analysis Period (min)			15									

HCM Unsignalized Intersection Capacity Analysis  
 108: SW Middleton Rd & SW Brookman Rd

02/05/2019



Movement	EBL	EBT	EBR	WBL	WBT	WBR	NBL	NBT	NBR	SBL	SBT	SBR
Lane Configurations		↕			↕			↕			↕	
Traffic Volume (veh/h)	3	110	17	2	110	6	16	11	10	9	4	3
Future Volume (Veh/h)	3	110	17	2	110	6	16	11	10	9	4	3
Sign Control		Stop			Stop			Free			Free	
Grade		-1%			1%			-2%			0%	
Peak Hour Factor	0.72	0.72	0.72	0.72	0.72	0.72	0.72	0.72	0.72	0.72	0.72	0.72
Hourly flow rate (vph)	4	153	24	3	153	8	22	15	14	13	6	4
Pedestrians												
Lane Width (ft)												
Walking Speed (ft/s)												
Percent Blockage												
Right turn flare (veh)												
Median type								None			None	
Median storage (veh)												
Upstream signal (ft)												
pX, platoon unblocked												
vC, conflicting volume	184	107	8	200	102	22	10			29		
vC1, stage 1 conf vol												
vC2, stage 2 conf vol												
vCu, unblocked vol	184	107	8	200	102	22	10			29		
tC, single (s)	7.1	6.5	6.2	7.6	6.6	6.4	4.1			4.1		
tC, 2 stage (s)												
tF (s)	3.5	4.0	3.3	4.0	4.0	3.5	2.2			2.2		
p0 queue free %	99	80	98	99	80	99	99			99		
cM capacity (veh/h)	645	768	1080	542	765	1013	1623			1597		
<b>Direction, Lane #</b>	<b>EB 1</b>	<b>WB 1</b>	<b>NB 1</b>	<b>SB 1</b>								
Volume Total	181	164	51	23								
Volume Left	4	3	22	13								
Volume Right	24	8	14	4								
cSH	795	769	1623	1597								
Volume to Capacity	0.23	0.21	0.01	0.01								
Queue Length 95th (ft)	22	20	1	1								
Control Delay (s)	10.9	10.9	3.2	4.1								
Lane LOS	B	B	A	A								
Approach Delay (s)	10.9	10.9	3.2	4.1								
Approach LOS	B	B										
<b>Intersection Summary</b>												
Average Delay			9.6									
Intersection Capacity Utilization			18.5%		ICU Level of Service				A			
Analysis Period (min)			15									

HCM Unsignalized Intersection Capacity Analysis  
 109: SW Oberst Rd/Site Access & SW Brookman Rd

02/05/2019



Movement	EBL	EBT	EBR	WBL	WBT	WBR	NBL	NBT	NBR	SBL	SBT	SBR
Lane Configurations		↕			↕			↕			↕	
Traffic Volume (veh/h)	18	111	3	1	64	12	3	0	3	35	0	50
Future Volume (Veh/h)	18	111	3	1	64	12	3	0	3	35	0	50
Sign Control		Free			Free			Stop			Stop	
Grade		-3%			2%			1%			0%	
Peak Hour Factor	0.68	0.68	0.68	0.68	0.68	0.68	0.68	0.68	0.68	0.68	0.68	0.68
Hourly flow rate (vph)	26	163	4	1	94	18	4	0	4	51	0	74
Pedestrians					1						2	
Lane Width (ft)					12.0						12.0	
Walking Speed (ft/s)					3.5						3.5	
Percent Blockage					0						0	
Right turn flare (veh)												
Median type		None			None							
Median storage (veh)												
Upstream signal (ft)												
pX, platoon unblocked												
vC, conflicting volume	114			167			396	333	166	329	326	105
vC1, stage 1 conf vol												
vC2, stage 2 conf vol												
vCu, unblocked vol	114			167			396	333	166	329	326	105
tC, single (s)	4.1			4.1			7.1	6.5	6.5	7.1	6.5	6.2
tC, 2 stage (s)												
tF (s)	2.2			2.2			3.5	4.0	3.6	3.5	4.0	3.3
p0 queue free %	98			100			99	100	100	92	100	92
cM capacity (veh/h)	1485			1423			515	578	803	614	584	953
<b>Direction, Lane #</b>	<b>EB 1</b>	<b>WB 1</b>	<b>NB 1</b>	<b>SB 1</b>								
Volume Total	193	113	8	125								
Volume Left	26	1	4	51								
Volume Right	4	18	4	74								
cSH	1485	1423	628	778								
Volume to Capacity	0.02	0.00	0.01	0.16								
Queue Length 95th (ft)	1	0	1	14								
Control Delay (s)	1.1	0.1	10.8	10.5								
Lane LOS	A	A	B	B								
Approach Delay (s)	1.1	0.1	10.8	10.5								
Approach LOS			B	B								
<b>Intersection Summary</b>												
Average Delay			3.7									
Intersection Capacity Utilization			26.2%		ICU Level of Service				A			
Analysis Period (min)			15									

# HCM Unsignalized Intersection Capacity Analysis

## 110: SW Ladd Hill Rd & SW Brookman Rd

02/05/2019



Movement	EBL	EBR	NBL	NBT	SBT	SBR
Lane Configurations						
Traffic Volume (veh/h)	122	34	22	112	42	49
Future Volume (Veh/h)	122	34	22	112	42	49
Sign Control	Stop			Free	Free	
Grade	2%			-1%	0%	
Peak Hour Factor	0.70	0.70	0.70	0.70	0.70	0.70
Hourly flow rate (vph)	174	49	31	160	60	70
Pedestrians					1	
Lane Width (ft)					12.0	
Walking Speed (ft/s)					3.5	
Percent Blockage					0	
Right turn flare (veh)						
Median type				None	None	
Median storage (veh)						
Upstream signal (ft)						
pX, platoon unblocked						
vC, conflicting volume	318	95	130			
vC1, stage 1 conf vol						
vC2, stage 2 conf vol						
vCu, unblocked vol	318	95	130			
tC, single (s)	6.4	6.3	4.3			
tC, 2 stage (s)						
tF (s)	3.5	3.4	2.4			
p0 queue free %	74	95	98			
cM capacity (veh/h)	659	945	1368			
<b>Direction, Lane #</b>	<b>EB 1</b>	<b>NB 1</b>	<b>SB 1</b>			
Volume Total	223	191	130			
Volume Left	174	31	0			
Volume Right	49	0	70			
cSH	706	1368	1700			
Volume to Capacity	0.32	0.02	0.08			
Queue Length 95th (ft)	34	2	0			
Control Delay (s)	12.4	1.4	0.0			
Lane LOS	B	A				
Approach Delay (s)	12.4	1.4	0.0			
Approach LOS	B					
<b>Intersection Summary</b>						
Average Delay			5.6			
Intersection Capacity Utilization			29.3%	ICU Level of Service	A	
Analysis Period (min)			15			

Queues

101: SW Pacific Hwy & SW Elwert Rd/SW Sunset Blvd

02/05/2019



Lane Group	EBL	EBT	WBL	WBT	NBL	NBT	NBR	SBL	SBT	SBR
Lane Group Flow (vph)	48	520	144	306	263	1123	141	299	1862	48
v/c Ratio	0.47	0.92dr	0.95	0.39	0.95	0.64	0.17	0.80	1.01	0.05
Control Delay	85.3	53.7	129.1	28.7	112.1	31.1	10.1	82.4	57.8	0.6
Queue Delay	0.0	0.0	0.0	0.0	0.0	0.0	0.0	0.0	0.0	0.0
Total Delay	85.3	53.7	129.1	28.7	112.1	31.1	10.1	82.4	57.8	0.6
Queue Length 50th (ft)	47	191	144	72	135	425	29	150	~959	0
Queue Length 95th (ft)	98	258	#312	121	#250	573	78	#235	#1284	4
Internal Link Dist (ft)		263		568		888			476	
Turn Bay Length (ft)					320		150	210		300
Base Capacity (vph)	127	855	151	904	276	1742	834	389	1851	884
Starvation Cap Reductn	0	0	0	0	0	0	0	0	0	0
Spillback Cap Reductn	0	0	0	0	0	0	0	0	0	0
Storage Cap Reductn	0	0	0	0	0	0	0	0	0	0
Reduced v/c Ratio	0.38	0.61	0.95	0.34	0.95	0.64	0.17	0.77	1.01	0.05

Intersection Summary

~ Volume exceeds capacity, queue is theoretically infinite.

Queue shown is maximum after two cycles.

# 95th percentile volume exceeds capacity, queue may be longer.

Queue shown is maximum after two cycles.

dr Defacto Right Lane. Recode with 1 though lane as a right lane.



HCM Unsignalized Intersection Capacity Analysis  
 102: SW Woodhaven Dr & SW Sunset Blvd

02/05/2019



Movement	EBL	EBT	EBR	WBL	WBT	WBR	NBL	NBT	NBR	SBL	SBT	SBR
Lane Configurations												
Traffic Volume (veh/h)	121	389	26	5	416	73	12	0	1	38	1	64
Future Volume (Veh/h)	121	389	26	5	416	73	12	0	1	38	1	64
Sign Control		Free			Free			Stop			Stop	
Grade		-1%			1%			-2%			0%	
Peak Hour Factor	0.92	0.92	0.92	0.92	0.92	0.92	0.92	0.92	0.92	0.92	0.92	0.92
Hourly flow rate (vph)	132	423	28	5	452	79	13	0	1	41	1	70
Pedestrians												
Lane Width (ft)												
Walking Speed (ft/s)												
Percent Blockage												
Right turn flare (veh)												
Median type		None			None							
Median storage (veh)												
Upstream signal (ft)		648										
pX, platoon unblocked												
vC, conflicting volume	531			451			1220	1228	423	1190	1216	492
vC1, stage 1 conf vol												
vC2, stage 2 conf vol												
vCu, unblocked vol	531			451			1220	1228	423	1190	1216	492
tC, single (s)	4.1			4.1			7.1	6.5	6.2	7.1	6.5	6.2
tC, 2 stage (s)												
tF (s)	2.2			2.2			3.5	4.0	3.3	3.5	4.0	3.3
p0 queue free %	87			100			90	100	100	73	99	88
cM capacity (veh/h)	1042			1120			125	156	635	149	159	577
Direction, Lane #	EB 1	EB 2	EB 3	WB 1	WB 2	NB 1	SB 1					
Volume Total	132	423	28	5	531	14	112					
Volume Left	132	0	0	5	0	13	41					
Volume Right	0	0	28	0	79	1	70					
cSH	1042	1700	1700	1120	1700	133	278					
Volume to Capacity	0.13	0.25	0.02	0.00	0.31	0.11	0.40					
Queue Length 95th (ft)	11	0	0	0	0	9	46					
Control Delay (s)	9.0	0.0	0.0	8.2	0.0	35.4	26.4					
Lane LOS	A			A		E	D					
Approach Delay (s)	2.0			0.1		35.4	26.4					
Approach LOS						E	D					
Intersection Summary												
Average Delay			3.8									
Intersection Capacity Utilization			48.6%		ICU Level of Service		A					
Analysis Period (min)			15									

HCM Unsignalized Intersection Capacity Analysis  
 103: SW Timbrel Ln & SW Sunset Blvd

02/05/2019



Movement	EBT	EBR	WBL	WBT	NBL	NBR
Lane Configurations	↔		↔	↔	↔	
Traffic Volume (veh/h)	314	115	63	403	92	37
Future Volume (Veh/h)	314	115	63	403	92	37
Sign Control	Free			Free	Stop	
Grade	-1%			1%	0%	
Peak Hour Factor	0.91	0.91	0.91	0.91	0.91	0.91
Hourly flow rate (vph)	345	126	69	443	101	41
Pedestrians				1		
Lane Width (ft)				12.0		
Walking Speed (ft/s)				3.5		
Percent Blockage				0		
Right turn flare (veh)						
Median type	None			None		
Median storage (veh)						
Upstream signal (ft)	1264					
pX, platoon unblocked						
vC, conflicting volume			471		989	409
vC1, stage 1 conf vol						
vC2, stage 2 conf vol						
vCu, unblocked vol			471		989	409
tC, single (s)			4.1		6.4	6.2
tC, 2 stage (s)						
tF (s)			2.2		3.5	3.3
p0 queue free %			94		61	94
cM capacity (veh/h)			1086		256	640

Direction, Lane #	EB 1	WB 1	WB 2	NB 1
Volume Total	471	69	443	142
Volume Left	0	69	0	101
Volume Right	126	0	0	41
cSH	1700	1086	1700	310
Volume to Capacity	0.28	0.06	0.26	0.46
Queue Length 95th (ft)	0	5	0	57
Control Delay (s)	0.0	8.5	0.0	26.1
Lane LOS		A		D
Approach Delay (s)	0.0	1.2		26.1
Approach LOS				D

Intersection Summary			
Average Delay		3.8	
Intersection Capacity Utilization	44.6%		ICU Level of Service A
Analysis Period (min)		15	

**Intersection**

Intersection Delay, s/veh	36.9
Intersection LOS	E

Movement	EBL	EBT	EBR	WBL	WBT	WBR	NBL	NBT	NBR	SBL	SBT	SBR
Lane Configurations	↶	↷		↶	↷		↶	↷		↶	↷	
Traffic Vol, veh/h	27	133	134	52	103	52	99	231	39	69	377	41
Future Vol, veh/h	27	133	134	52	103	52	99	231	39	69	377	41
Peak Hour Factor	0.89	0.89	0.89	0.89	0.89	0.89	0.89	0.89	0.89	0.89	0.89	0.89
Heavy Vehicles, %	0	2	1	3	0	2	0	3	0	2	1	3
Mvmt Flow	30	149	151	58	116	58	111	260	44	78	424	46
Number of Lanes	1	1	0	1	1	0	1	1	0	1	1	0

Approach	EB	WB	NB	SB
Opposing Approach	WB	EB	SB	NB
Opposing Lanes	2	2	2	2
Conflicting Approach Left	SB	NB	EB	WB
Conflicting Lanes Left	2	2	2	2
Conflicting Approach Right	NB	SB	WB	EB
Conflicting Lanes Right	2	2	2	2
HCM Control Delay	24.6	16.3	22.8	63.9
HCM LOS	C	C	C	F

Lane	NBLn1	NBLn2	EBLn1	EBLn2	WBLn1	WBLn2	SBLn1	SBLn2
Vol Left, %	100%	0%	100%	0%	100%	0%	100%	0%
Vol Thru, %	0%	86%	0%	50%	0%	66%	0%	90%
Vol Right, %	0%	14%	0%	50%	0%	34%	0%	10%
Sign Control	Stop	Stop	Stop	Stop	Stop	Stop	Stop	Stop
Traffic Vol by Lane	99	270	27	267	52	155	69	418
LT Vol	99	0	27	0	52	0	69	0
Through Vol	0	231	0	133	0	103	0	377
RT Vol	0	39	0	134	0	52	0	41
Lane Flow Rate	111	303	30	300	58	174	78	470
Geometry Grp	7	7	7	7	7	7	7	7
Degree of Util (X)	0.264	0.673	0.074	0.668	0.15	0.409	0.18	1.011
Departure Headway (Hd)	8.676	8.106	9.029	8.18	9.451	8.632	8.35	7.746
Convergence, Y/N	Yes	Yes	Yes	Yes	Yes	Yes	Yes	Yes
Cap	417	449	399	444	382	420	433	474
Service Time	6.376	5.806	6.729	5.88	7.151	6.332	6.045	5.441
HCM Lane V/C Ratio	0.266	0.675	0.075	0.676	0.152	0.414	0.18	0.992
HCM Control Delay	14.5	25.9	12.4	25.8	13.8	17.2	12.9	72.3
HCM Lane LOS	B	D	B	D	B	C	B	F
HCM 95th-tile Q	1	4.9	0.2	4.8	0.5	2	0.6	13.6

**Intersection**

Intersection Delay, s/veh	32
Intersection LOS	D

Movement	EBL	EBT	EBR	WBL	WBT	WBR	NBL	NBT	NBR	SBL	SBT	SBR
Lane Configurations												
Traffic Vol, veh/h	110	14	171	1	21	16	322	143	6	32	149	282
Future Vol, veh/h	110	14	171	1	21	16	322	143	6	32	149	282
Peak Hour Factor	0.90	0.90	0.90	0.90	0.90	0.90	0.90	0.90	0.90	0.90	0.90	0.90
Heavy Vehicles, %	0	0	5	100	0	0	2	1	0	0	2	2
Mvmt Flow	122	16	190	1	23	18	358	159	7	36	166	313
Number of Lanes	1	1	0	0	1	0	0	1	0	0	1	0

Approach	EB	WB	NB	SB
Opposing Approach	WB	EB	SB	NB
Opposing Lanes	1	2	1	1
Conflicting Approach Left	SB	NB	EB	WB
Conflicting Lanes Left	1	1	2	1
Conflicting Approach Right	NB	SB	WB	EB
Conflicting Lanes Right	1	1	1	2
HCM Control Delay	14.1	14	44.6	32
HCM LOS	B	B	E	D

Lane	NBLn1	EBLn1	EBLn2	WBLn1	SBLn1
Vol Left, %	68%	100%	0%	3%	7%
Vol Thru, %	30%	0%	8%	55%	32%
Vol Right, %	1%	0%	92%	42%	61%
Sign Control	Stop	Stop	Stop	Stop	Stop
Traffic Vol by Lane	471	110	185	38	463
LT Vol	322	110	0	1	32
Through Vol	143	0	14	21	149
RT Vol	6	0	171	16	282
Lane Flow Rate	523	122	206	42	514
Geometry Grp	2	7	7	5	2
Degree of Util (X)	0.914	0.275	0.395	0.113	0.837
Departure Headway (Hd)	6.289	8.101	6.919	9.66	5.856
Convergence, Y/N	Yes	Yes	Yes	Yes	Yes
Cap	576	444	520	370	617
Service Time	4.336	5.857	4.674	7.754	3.902
HCM Lane V/C Ratio	0.908	0.275	0.396	0.114	0.833
HCM Control Delay	44.6	13.9	14.2	14	32
HCM Lane LOS	E	B	B	B	D
HCM 95th-tile Q	11.2	1.1	1.9	0.4	9

HCM Unsignalized Intersection Capacity Analysis  
 106: SW Pacific Hwy & SW Chapman Rd

02/05/2019

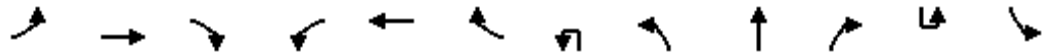

Movement	EBL	EBT	EBR	WBL	WBT	WBR	NBU	NBL	NBT	NBR	SBU	SBL
Lane Configurations		↔			↔			↔	↕			↔
Traffic Volume (veh/h)	20	7	12	46	5	54	1	8	1368	55	2	65
Future Volume (Veh/h)	20	7	12	46	5	54	1	8	1368	55	2	65
Sign Control		Stop			Stop				Free			
Grade		0%			0%				0%			
Peak Hour Factor	0.96	0.96	0.96	0.96	0.96	0.96	0.96	0.96	0.96	0.96	0.96	0.96
Hourly flow rate (vph)	21	7	13	48	5	56	0	8	1425	57	0	68
Pedestrians												
Lane Width (ft)												
Walking Speed (ft/s)												
Percent Blockage												
Right turn flare (veh)												
Median type												
Median storage veh												
Upstream signal (ft)												
pX, platoon unblocked							0.00				0.00	
vC, conflicting volume	3108	3819	1092	2714	3834	741	0	2229			0	1482
vC1, stage 1 conf vol	2321	2321		1470	1470							
vC2, stage 2 conf vol	787	1498		1245	2365							
vCu, unblocked vol	3108	3819	1092	2714	3834	741	0	2229			0	1482
tC, single (s)	7.6	6.5	6.9	7.6	6.5	6.9	0.0	4.1			0.0	4.1
tC, 2 stage (s)	6.6	5.5		6.6	5.5							
tF (s)	3.5	4.0	3.3	3.5	4.0	3.3	0.0	2.2			0.0	2.2
p0 queue free %	30	86	94	42	89	85	0	97			0	85
cM capacity (veh/h)	30	51	213	83	47	363	0	237			0	460
<b>Direction, Lane #</b>												
	EB 1	WB 1	NB 1	NB 2	NB 3	SB 1	SB 2	SB 3	SB 4			
Volume Total	41	109	8	950	532	68	1092	1092	44			
Volume Left	21	48	8	0	0	68	0	0	0			
Volume Right	13	56	0	0	57	0	0	0	44			
cSH	46	130	237	1700	1700	460	1700	1700	1700			
Volume to Capacity	0.90	0.84	0.03	0.56	0.31	0.15	0.64	0.64	0.03			
Queue Length 95th (ft)	91	130	3	0	0	13	0	0	0			
Control Delay (s)	240.2	104.1	20.7	0.0	0.0	14.2	0.0	0.0	0.0			
Lane LOS	F	F	C			B						
Approach Delay (s)	240.2	104.1	0.1			0.4						
Approach LOS	F	F										
<b>Intersection Summary</b>												
Average Delay			5.7									
Intersection Capacity Utilization			71.9%		ICU Level of Service				C			
Analysis Period (min)			15									

HCM Unsignalized Intersection Capacity Analysis  
 106: SW Pacific Hwy & SW Chapman Rd

02/05/2019



Movement	SBT	SBR
Lane Configurations	↑↑	↑
Traffic Volume (veh/h)	2098	42
Future Volume (Veh/h)	2098	42
Sign Control	Free	
Grade	0%	
Peak Hour Factor	0.96	0.96
Hourly flow rate (vph)	2185	44
Pedestrians		
Lane Width (ft)		
Walking Speed (ft/s)		
Percent Blockage		
Right turn flare (veh)		
Median type	Raised	
Median storage veh)	2	
Upstream signal (ft)		
pX, platoon unblocked		
vC, conflicting volume		
vC1, stage 1 conf vol		
vC2, stage 2 conf vol		
vCu, unblocked vol		
tC, single (s)		
tC, 2 stage (s)		
tF (s)		
p0 queue free %		
cM capacity (veh/h)		
Direction, Lane #		

HCM Unsignalized Intersection Capacity Analysis  
 107: SW Old Hwy 99W & SW Brookman Rd

02/05/2019



Movement	EBL	EBT	EBR	WBL	WBT	WBR	NBL	NBT	NBR	SBL	SBT	SBR
Lane Configurations		↕			↕			↕			↕	
Traffic Volume (veh/h)	10	110	1	1	100	2	1	1	2	1	1	1
Future Volume (Veh/h)	10	110	1	1	100	2	1	1	2	1	1	1
Sign Control		Free			Free			Stop			Stop	
Grade		0%			2%			2%			-2%	
Peak Hour Factor	0.82	0.82	0.82	0.82	0.82	0.82	0.82	0.82	0.82	0.82	0.82	0.82
Hourly flow rate (vph)	12	134	1	1	122	2	1	1	2	1	1	1
Pedestrians												
Lane Width (ft)												
Walking Speed (ft/s)												
Percent Blockage												
Right turn flare (veh)												
Median type		None			None							
Median storage (veh)												
Upstream signal (ft)												
pX, platoon unblocked												
vC, conflicting volume	124			135			285	284	134	286	284	123
vC1, stage 1 conf vol												
vC2, stage 2 conf vol												
vCu, unblocked vol	124			135			285	284	134	286	284	123
tC, single (s)	4.1			4.1			7.1	6.5	6.2	7.1	6.5	6.2
tC, 2 stage (s)												
tF (s)	2.2			2.2			3.5	4.0	3.3	3.5	4.0	3.3
p0 queue free %	99			100			100	100	100	100	100	100
cM capacity (veh/h)	1475			1462			665	622	920	664	623	933
<b>Direction, Lane #</b>	<b>EB 1</b>	<b>WB 1</b>	<b>NB 1</b>	<b>SB 1</b>								
Volume Total	147	125	4	3								
Volume Left	12	1	1	1								
Volume Right	1	2	2	1								
cSH	1475	1462	757	717								
Volume to Capacity	0.01	0.00	0.01	0.00								
Queue Length 95th (ft)	1	0	0	0								
Control Delay (s)	0.7	0.1	9.8	10.0								
Lane LOS	A	A	A	B								
Approach Delay (s)	0.7	0.1	9.8	10.0								
Approach LOS			A	B								
<b>Intersection Summary</b>												
Average Delay			0.6									
Intersection Capacity Utilization			22.4%		ICU Level of Service				A			
Analysis Period (min)			15									

HCM Unsignalized Intersection Capacity Analysis  
 108: SW Middleton Rd & SW Brookman Rd

02/05/2019



Movement	EBL	EBT	EBR	WBL	WBT	WBR	NBL	NBT	NBR	SBL	SBT	SBR
Lane Configurations		↕			↕			↕			↕	
Traffic Volume (veh/h)	10	92	16	12	80	6	15	6	8	7	10	4
Future Volume (Veh/h)	10	92	16	12	80	6	15	6	8	7	10	4
Sign Control		Stop			Stop			Free			Free	
Grade		-1%			1%			-2%			0%	
Peak Hour Factor	0.74	0.74	0.74	0.74	0.74	0.74	0.74	0.74	0.74	0.74	0.74	0.74
Hourly flow rate (vph)	14	124	22	16	108	8	20	8	11	9	14	5
Pedestrians		1			1						1	
Lane Width (ft)		12.0			12.0						12.0	
Walking Speed (ft/s)		3.5			3.5						3.5	
Percent Blockage		0			0						0	
Right turn flare (veh)												
Median type								None			None	
Median storage (veh)												
Upstream signal (ft)												
pX, platoon unblocked												
vC, conflicting volume	152	96	18	173	92	16	20			20		
vC1, stage 1 conf vol												
vC2, stage 2 conf vol												
vCu, unblocked vol	152	96	18	173	92	16	20			20		
tC, single (s)	7.1	6.5	6.2	7.2	6.5	6.2	4.2			4.1		
tC, 2 stage (s)												
tF (s)	3.5	4.0	3.3	3.6	4.0	3.3	2.3			2.2		
p0 queue free %	98	84	98	98	86	99	99			99		
cM capacity (veh/h)	715	782	1066	655	785	1068	1514			1608		
<b>Direction, Lane #</b>	<b>EB 1</b>	<b>WB 1</b>	<b>NB 1</b>	<b>SB 1</b>								
Volume Total	160	132	39	28								
Volume Left	14	16	20	9								
Volume Right	22	8	11	5								
cSH	805	779	1514	1608								
Volume to Capacity	0.20	0.17	0.01	0.01								
Queue Length 95th (ft)	18	15	1	0								
Control Delay (s)	10.6	10.6	3.8	2.4								
Lane LOS	B	B	A	A								
Approach Delay (s)	10.6	10.6	3.8	2.4								
Approach LOS	B	B										
<b>Intersection Summary</b>												
Average Delay			9.2									
Intersection Capacity Utilization			18.2%		ICU Level of Service					A		
Analysis Period (min)			15									



HCM Unsignalized Intersection Capacity Analysis  
 109: SW Oberst Rd/Site Access & SW Brookman Rd

02/05/2019



Movement	EBL	EBT	EBR	WBL	WBT	WBR	NBL	NBT	NBR	SBL	SBT	SBR
Lane Configurations		↕			↕			↕			↕	
Traffic Volume (veh/h)	57	51	0	4	67	36	4	0	4	23	0	32
Future Volume (Veh/h)	57	51	0	4	67	36	4	0	4	23	0	32
Sign Control		Free			Free			Stop			Stop	
Grade		-3%			2%			1%			0%	
Peak Hour Factor	0.69	0.69	0.69	0.69	0.69	0.69	0.69	0.69	0.69	0.69	0.69	0.69
Hourly flow rate (vph)	83	74	0	6	97	52	6	0	6	33	0	46
Pedestrians												2
Lane Width (ft)												12.0
Walking Speed (ft/s)												3.5
Percent Blockage												0
Right turn flare (veh)												
Median type		None			None							
Median storage (veh)												
Upstream signal (ft)												
pX, platoon unblocked												
vC, conflicting volume	151			74			421	403	74	383	377	125
vC1, stage 1 conf vol												
vC2, stage 2 conf vol												
vCu, unblocked vol	151			74			421	403	74	383	377	125
tC, single (s)	4.1			4.1			7.4	6.5	6.5	7.1	6.5	6.2
tC, 2 stage (s)												
tF (s)	2.2			2.2			3.7	4.0	3.5	3.5	4.0	3.3
p0 queue free %	94			100			99	100	99	94	100	95
cM capacity (veh/h)	1440			1538			456	505	927	546	523	929
<b>Direction, Lane #</b>	<b>EB 1</b>	<b>WB 1</b>	<b>NB 1</b>	<b>SB 1</b>								
Volume Total	157	155	12	79								
Volume Left	83	6	6	33								
Volume Right	0	52	6	46								
cSH	1440	1538	612	719								
Volume to Capacity	0.06	0.00	0.02	0.11								
Queue Length 95th (ft)	5	0	1	9								
Control Delay (s)	4.3	0.3	11.0	10.6								
Lane LOS	A	A	B	B								
Approach Delay (s)	4.3	0.3	11.0	10.6								
Approach LOS			B	B								
<b>Intersection Summary</b>												
Average Delay			4.2									
Intersection Capacity Utilization			23.0%		ICU Level of Service				A			
Analysis Period (min)			15									

HCM Unsignalized Intersection Capacity Analysis  
 110: SW Ladd Hill Rd & SW Brookman Rd

02/05/2019



Movement	EBL	EBR	NBL	NBT	SBT	SBR
Lane Configurations						
Traffic Volume (veh/h)	51	21	19	86	95	82
Future Volume (Veh/h)	51	21	19	86	95	82
Sign Control	Stop			Free	Free	
Grade	2%			-1%	0%	
Peak Hour Factor	0.78	0.78	0.78	0.78	0.78	0.78
Hourly flow rate (vph)	65	27	24	110	122	105
Pedestrians						
Lane Width (ft)						
Walking Speed (ft/s)						
Percent Blockage						
Right turn flare (veh)						
Median type						
				None	None	
Median storage (veh)						
Upstream signal (ft)						
pX, platoon unblocked						
vC, conflicting volume	332	174	227			
vC1, stage 1 conf vol						
vC2, stage 2 conf vol						
vCu, unblocked vol	332	174	227			
tC, single (s)	6.4	6.3	4.1			
tC, 2 stage (s)						
tF (s)	3.5	3.4	2.2			
p0 queue free %	90	97	98			
cM capacity (veh/h)	648	856	1353			
<b>Direction, Lane #</b>	<b>EB 1</b>	<b>NB 1</b>	<b>SB 1</b>			
Volume Total	92	134	227			
Volume Left	65	24	0			
Volume Right	27	0	105			
cSH	698	1353	1700			
Volume to Capacity	0.13	0.02	0.13			
Queue Length 95th (ft)	11	1	0			
Control Delay (s)	10.9	1.5	0.0			
Lane LOS	B	A				
Approach Delay (s)	10.9	1.5	0.0			
Approach LOS	B					
<b>Intersection Summary</b>						
Average Delay			2.7			
Intersection Capacity Utilization			29.7%	ICU Level of Service	A	
Analysis Period (min)			15			

Appendix F Background Conditions  
Level of Service Worksheets

HCM Signalized Intersection Capacity Analysis  
 101: SW Pacific Hwy & SW Elwert Rd/SW Sunset Blvd

02/05/2019



Movement	EBL	EBT	EBR	WBL	WBT	WBR	NBL	NBT	NBR	SBL	SBT	SBR
Lane Configurations	↖	↕		↖	↕		↖	↕	↗	↖	↕	↗
Traffic Volume (vph)	131	237	279	108	387	219	331	1576	112	129	755	194
Future Volume (vph)	131	237	279	108	387	219	331	1576	112	129	755	194
Ideal Flow (vphpl)	1900	1900	1900	1900	1900	1900	1900	1900	1900	1900	1900	1900
Grade (%)		0%			0%			-1%				2%
Total Lost time (s)	4.5	6.0		4.5	6.0		5.0	6.0	6.0	5.0	6.0	6.0
Lane Util. Factor	1.00	0.95		1.00	0.95		0.97	0.95	1.00	0.97	0.95	1.00
Frpb, ped/bikes	1.00	1.00		1.00	1.00		1.00	1.00	1.00	1.00	1.00	0.98
Flpb, ped/bikes	1.00	1.00		1.00	1.00		1.00	1.00	1.00	1.00	1.00	1.00
Frt	1.00	0.92		1.00	0.95		1.00	1.00	0.85	1.00	1.00	0.85
Flt Protected	0.95	1.00		0.95	1.00		0.95	1.00	1.00	0.95	1.00	1.00
Satd. Flow (prot)	1805	3209		1770	3303		3417	3489	1561	3180	3279	1505
Flt Permitted	0.95	1.00		0.95	1.00		0.95	1.00	1.00	0.95	1.00	1.00
Satd. Flow (perm)	1805	3209		1770	3303		3417	3489	1561	3180	3279	1505
Peak-hour factor, PHF	0.95	0.95	0.95	0.95	0.95	0.95	0.95	0.95	0.95	0.95	0.95	0.95
Adj. Flow (vph)	138	249	294	114	407	231	348	1659	118	136	795	204
RTOR Reduction (vph)	0	136	0	0	50	0	0	0	43	0	0	114
Lane Group Flow (vph)	138	407	0	114	588	0	348	1659	75	136	795	90
Confl. Bikes (#/hr)												1
Heavy Vehicles (%)	0%	5%	2%	2%	3%	4%	3%	4%	4%	9%	9%	4%
Turn Type	Prot	NA		Prot	NA		Prot	NA	Perm	Prot	NA	Perm
Protected Phases	7	4		3	8		5	2		1	6	
Permitted Phases									2			6
Actuated Green, G (s)	13.5	33.5		12.8	32.8		19.4	77.2	77.2	11.7	69.5	69.5
Effective Green, g (s)	13.5	33.5		12.8	32.8		19.4	77.2	77.2	11.7	69.5	69.5
Actuated g/C Ratio	0.09	0.21		0.08	0.21		0.12	0.49	0.49	0.07	0.44	0.44
Clearance Time (s)	4.5	6.0		4.5	6.0		5.0	6.0	6.0	5.0	6.0	6.0
Vehicle Extension (s)	3.0	3.0		3.0	3.0		3.0	5.4	5.4	3.5	5.4	5.4
Lane Grp Cap (vph)	155	686		144	691		423	1718	769	237	1454	667
v/s Ratio Prot	c0.08	0.13		0.06	c0.18		c0.10	c0.48		0.04	0.24	
v/s Ratio Perm									0.05			0.06
v/c Ratio	0.89	0.59		0.79	0.85		0.82	0.97	0.10	0.57	0.55	0.14
Uniform Delay, d1	70.9	55.5		70.6	59.6		67.0	38.5	21.2	70.1	32.0	25.8
Progression Factor	1.00	1.00		1.00	1.00		1.00	1.00	1.00	1.00	1.00	1.00
Incremental Delay, d2	42.0	1.4		25.0	9.9		12.2	14.6	0.1	3.6	0.8	0.2
Delay (s)	112.8	56.8		95.6	69.5		79.2	53.1	21.3	73.7	32.9	26.0
Level of Service	F	E		F	E		E	D	C	E	C	C
Approach Delay (s)		68.2			73.4			55.6			36.5	
Approach LOS		E			E			E			D	

Intersection Summary

HCM 2000 Control Delay	55.7	HCM 2000 Level of Service	E
HCM 2000 Volume to Capacity ratio	0.93		
Actuated Cycle Length (s)	156.7	Sum of lost time (s)	21.5
Intersection Capacity Utilization	90.1%	ICU Level of Service	E
Analysis Period (min)	15		
c Critical Lane Group			

HCM Unsignalized Intersection Capacity Analysis  
 102: SW Woodhaven Dr & SW Sunset Blvd

02/05/2019



Movement	EBL	EBT	EBR	WBL	WBT	WBR	NBL	NBT	NBR	SBL	SBT	SBR
Lane Configurations												
Traffic Volume (veh/h)	55	338	74	7	562	91	20	15	11	29	47	119
Future Volume (Veh/h)	55	338	74	7	562	91	20	15	11	29	47	119
Sign Control		Free			Free			Stop			Stop	
Grade		-1%			1%			-2%			0%	
Peak Hour Factor	0.80	0.80	0.80	0.80	0.80	0.80	0.80	0.80	0.80	0.80	0.80	0.80
Hourly flow rate (vph)	69	423	93	9	703	114	25	19	14	36	59	149
Pedestrians					5							3
Lane Width (ft)					12.0							12.0
Walking Speed (ft/s)					3.5							3.5
Percent Blockage					0							0
Right turn flare (veh)												
Median type		None			None							
Median storage (veh)												
Upstream signal (ft)		648										
pX, platoon unblocked				0.91			0.91	0.91	0.91	0.91	0.91	
vC, conflicting volume	820			516			1460	1399	428	1370	1435	763
vC1, stage 1 conf vol												
vC2, stage 2 conf vol												
vCu, unblocked vol	820			420			1457	1389	324	1358	1429	763
tC, single (s)	4.2			4.2			7.1	6.5	6.2	7.2	6.5	6.2
tC, 2 stage (s)												
tF (s)	2.3			2.3			3.5	4.0	3.3	3.6	4.0	3.3
p0 queue free %	91			99			27	84	98	59	47	63
cM capacity (veh/h)	781			982			34	118	655	88	112	406
<b>Direction, Lane #</b>	<b>EB 1</b>	<b>EB 2</b>	<b>EB 3</b>	<b>WB 1</b>	<b>WB 2</b>	<b>NB 1</b>	<b>SB 1</b>					
Volume Total	69	423	93	9	817	58	244					
Volume Left	69	0	0	9	0	25	36					
Volume Right	0	0	93	0	114	14	149					
cSH	781	1700	1700	982	1700	63	187					
Volume to Capacity	0.09	0.25	0.05	0.01	0.48	0.91	1.30					
Queue Length 95th (ft)	7	0	0	1	0	108	344					
Control Delay (s)	10.1	0.0	0.0	8.7	0.0	196.4	218.3					
Lane LOS	B			A		F	F					
Approach Delay (s)	1.2			0.1		196.4	218.3					
Approach LOS						F	F					
<b>Intersection Summary</b>												
Average Delay			38.2									
Intersection Capacity Utilization			60.4%		ICU Level of Service		B					
Analysis Period (min)			15									

# HCM Unsignalized Intersection Capacity Analysis

## 103: SW Timbrel Ln & SW Sunset Blvd



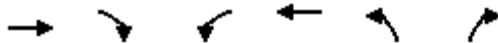

















02/05/2019



Movement	EBT	EBR	WBL	WBT	NBL	NBR
Lane Configurations	→		↵	↑	↵	
Traffic Volume (veh/h)	303	74	75	462	198	48
Future Volume (Veh/h)	303	74	75	462	198	48
Sign Control	Free			Free	Stop	
Grade	-1%			1%	0%	
Peak Hour Factor	0.84	0.84	0.84	0.84	0.84	0.84
Hourly flow rate (vph)	361	88	89	550	236	57
Pedestrians				21	1	
Lane Width (ft)				12.0	12.0	
Walking Speed (ft/s)				3.5	3.5	
Percent Blockage				2	0	
Right turn flare (veh)						
Median type	None			None		
Median storage (veh)						
Upstream signal (ft)	1264					
pX, platoon unblocked						
vC, conflicting volume			450	1134		427
vC1, stage 1 conf vol						
vC2, stage 2 conf vol						
vCu, unblocked vol			450	1134		427
tC, single (s)			4.2	6.4		6.3
tC, 2 stage (s)						
tF (s)			2.3	3.5		3.4
p0 queue free %			92	0		91
cM capacity (veh/h)			1089	203		604
Direction, Lane #	EB 1	WB 1	WB 2	NB 1		
Volume Total	449	89	550	293		
Volume Left	0	89	0	236		
Volume Right	88	0	0	57		
cSH	1700	1089	1700	233		
Volume to Capacity	0.26	0.08	0.32	1.26		
Queue Length 95th (ft)	0	7	0	372		
Control Delay (s)	0.0	8.6	0.0	188.7		
Lane LOS	A		F			
Approach Delay (s)	0.0	1.2	188.7			
Approach LOS					F	
Intersection Summary						
Average Delay			40.6			
Intersection Capacity Utilization			48.9%	ICU Level of Service		A
Analysis Period (min)			15			

HCM Unsignalized Intersection Capacity Analysis  
 104: SW Main St/SW Ladd Hill Rd & SW Sunset Blvd

02/05/2019

												
Movement	EBL	EBT	EBR	WBL	WBT	WBR	NBL	NBT	NBR	SBL	SBT	SBR
Lane Configurations												
Sign Control	Stop			Stop			Stop			Stop		
Traffic Volume (vph)	112	311	39	32	265	32	89	135	69	30	39	107
Future Volume (vph)	112	311	39	32	265	32	89	135	69	30	39	107
Peak Hour Factor	0.90	0.90	0.90	0.90	0.90	0.90	0.90	0.90	0.90	0.90	0.90	0.90
Hourly flow rate (vph)	124	346	43	36	294	36	99	150	77	33	43	119
Direction, Lane #	EB 1	EB 2	WB 1	WB 2	NB 1	NB 2	SB 1	SB 2				
Volume Total (vph)	124	389	36	330	99	227	33	162				
Volume Left (vph)	124	0	36	0	99	0	33	0				
Volume Right (vph)	0	43	0	36	0	77	0	119				
Hadj (s)	0.58	-0.05	0.72	-0.05	0.55	-0.18	0.50	-0.47				
Departure Headway (s)	7.5	6.8	7.8	7.0	8.0	7.3	8.2	7.3				
Degree Utilization, x	0.26	0.74	0.08	0.65	0.22	0.46	0.08	0.33				
Capacity (veh/h)	463	511	440	489	428	463	404	459				
Control Delay (s)	11.8	25.5	10.3	20.8	12.0	15.0	10.7	12.5				
Approach Delay (s)	22.2		19.7		14.1		12.2					
Approach LOS	C		C		B		B					
Intersection Summary												
Delay			18.3									
Level of Service			C									
Intersection Capacity Utilization			52.9%		ICU Level of Service				A			
Analysis Period (min)			15									

HCM Unsignalized Intersection Capacity Analysis  
 105: SW Baker Rd/SW Murdock Rd & SW Sunset Blvd

02/05/2019



Movement	EBL	EBT	EBR	WBL	WBT	WBR	NBL	NBT	NBR	SBL	SBT	SBR
Lane Configurations												
Sign Control	Stop				Stop			Stop			Stop	
Traffic Volume (vph)	272	9	219	5	23	24	138	141	3	5	116	103
Future Volume (vph)	272	9	219	5	23	24	138	141	3	5	116	103
Peak Hour Factor	0.91	0.91	0.91	0.91	0.91	0.91	0.91	0.91	0.91	0.91	0.91	0.91
Hourly flow rate (vph)	299	10	241	5	25	26	152	155	3	5	127	113

Direction, Lane #	EB 1	EB 2	WB 1	NB 1	SB 1
Volume Total (vph)	299	251	56	310	245
Volume Left (vph)	299	0	5	152	5
Volume Right (vph)	0	241	26	3	113
Hadj (s)	0.55	-0.60	-0.19	0.20	-0.16
Departure Headway (s)	6.8	5.7	6.5	6.1	5.9
Degree Utilization, x	0.57	0.40	0.10	0.53	0.40
Capacity (veh/h)	507	609	463	553	568
Control Delay (s)	17.3	11.2	10.3	15.8	12.9
Approach Delay (s)	14.5		10.3	15.8	12.9
Approach LOS	B		B	C	B

Intersection Summary

Delay	14.3
Level of Service	B
Intersection Capacity Utilization	59.7%
ICU Level of Service	B
Analysis Period (min)	15



HCM Unsignalized Intersection Capacity Analysis  
 106: SW Pacific Hwy & SW Chapman Rd

02/05/2019



Movement	EBL	EBT	EBR	WBL	WBT	WBR	NBU	NBL	NBT	NBR	SBU	SBL
Lane Configurations		↔			↔			↔	↕			↔
Traffic Volume (veh/h)	30	3	2	39	3	52	4	8	1914	89	3	25
Future Volume (Veh/h)	30	3	2	39	3	52	4	8	1914	89	3	25
Sign Control		Stop			Stop				Free			
Grade		0%			0%				0%			
Peak Hour Factor	0.96	0.96	0.96	0.96	0.96	0.96	0.96	0.96	0.96	0.96	0.96	0.96
Hourly flow rate (vph)	31	3	2	41	3	54	0	8	1994	93	0	26
Pedestrians												
Lane Width (ft)												
Walking Speed (ft/s)												
Percent Blockage												
Right turn flare (veh)												
Median type									Raised			
Median storage (veh)									2			
Upstream signal (ft)												
pX, platoon unblocked							0.00				0.00	
vC, conflicting volume	2272	3307	576	2688	3278	1044	0	1169			0	2087
vC1, stage 1 conf vol	1204	1204		2056	2056							
vC2, stage 2 conf vol	1068	2103		632	1221							
vCu, unblocked vol	2272	3307	576	2688	3278	1044	0	1169			0	2087
tC, single (s)	7.7	6.5	6.9	7.6	6.5	7.2	0.0	4.1			0.0	4.1
tC, 2 stage (s)	6.7	5.5		6.6	5.5							
tF (s)	3.6	4.0	3.3	3.5	4.0	3.4	0.0	2.2			0.0	2.2
p0 queue free %	68	95	100	21	96	74	0	99			0	90
cM capacity (veh/h)	98	62	466	52	86	208	0	605			0	269

Direction, Lane #	EB 1	WB 1	NB 1	NB 2	NB 3	SB 1	SB 2	SB 3	SB 4
Volume Total	36	98	8	1329	758	26	576	576	17
Volume Left	31	41	8	0	0	26	0	0	0
Volume Right	2	54	0	0	93	0	0	0	17
cSH	98	90	605	1700	1700	269	1700	1700	1700
Volume to Capacity	0.37	1.08	0.01	0.78	0.45	0.10	0.34	0.34	0.01
Queue Length 95th (ft)	37	164	1	0	0	8	0	0	0
Control Delay (s)	61.9	204.2	11.0	0.0	0.0	19.8	0.0	0.0	0.0
Lane LOS	F	F	B			C			
Approach Delay (s)	61.9	204.2	0.0			0.4			
Approach LOS	F	F							

Intersection Summary

Average Delay	6.7
Intersection Capacity Utilization	67.6%
ICU Level of Service	C
Analysis Period (min)	15

HCM Unsignalized Intersection Capacity Analysis  
 106: SW Pacific Hwy & SW Chapman Rd

02/05/2019



Movement	SBT	SBR
Lane Configurations	↑↑	↑
Traffic Volume (veh/h)	1106	16
Future Volume (Veh/h)	1106	16
Sign Control	Free	
Grade	0%	
Peak Hour Factor	0.96	0.96
Hourly flow rate (vph)	1152	17
Pedestrians		
Lane Width (ft)		
Walking Speed (ft/s)		
Percent Blockage		
Right turn flare (veh)		
Median type	Raised	
Median storage veh)	2	
Upstream signal (ft)		
pX, platoon unblocked		
vC, conflicting volume		
vC1, stage 1 conf vol		
vC2, stage 2 conf vol		
vCu, unblocked vol		
tC, single (s)		
tC, 2 stage (s)		
tF (s)		
p0 queue free %		
cM capacity (veh/h)		
Direction, Lane #		

HCM Unsignalized Intersection Capacity Analysis  
 107: SW Old Hwy 99W & SW Brookman Rd

02/05/2019



Movement	EBL	EBT	EBR	WBL	WBT	WBR	NBL	NBT	NBR	SBL	SBT	SBR
Lane Configurations		↕			↕			↕			↕	
Traffic Volume (veh/h)	11	104	2	0	73	3	3	2	2	8	3	15
Future Volume (Veh/h)	11	104	2	0	73	3	3	2	2	8	3	15
Sign Control		Free			Free			Stop			Stop	
Grade		0%			2%			2%			-2%	
Peak Hour Factor	0.69	0.69	0.69	0.69	0.69	0.69	0.69	0.69	0.69	0.69	0.69	0.69
Hourly flow rate (vph)	16	151	3	0	106	4	4	3	3	12	4	22
Pedestrians												
Lane Width (ft)												
Walking Speed (ft/s)												
Percent Blockage												
Right turn flare (veh)												
Median type		None			None							
Median storage (veh)												
Upstream signal (ft)												
pX, platoon unblocked												
vC, conflicting volume	110			154			316	294	152	297	294	108
vC1, stage 1 conf vol												
vC2, stage 2 conf vol												
vCu, unblocked vol	110			154			316	294	152	297	294	108
tC, single (s)	4.1			4.1			7.6	7.0	6.2	7.1	6.5	6.4
tC, 2 stage (s)												
tF (s)	2.2			2.2			4.0	4.5	3.3	3.5	4.0	3.5
p0 queue free %	99			100			99	99	100	98	99	98
cM capacity (veh/h)	1493			1439			532	538	899	649	614	897
<b>Direction, Lane #</b>	<b>EB 1</b>	<b>WB 1</b>	<b>NB 1</b>	<b>SB 1</b>								
Volume Total	170	110	10	38								
Volume Left	16	0	4	12								
Volume Right	3	4	3	22								
cSH	1493	1439	609	767								
Volume to Capacity	0.01	0.00	0.02	0.05								
Queue Length 95th (ft)	1	0	1	4								
Control Delay (s)	0.8	0.0	11.0	9.9								
Lane LOS	A		B	A								
Approach Delay (s)	0.8	0.0	11.0	9.9								
Approach LOS			B	A								
<b>Intersection Summary</b>												
Average Delay			1.9									
Intersection Capacity Utilization			22.9%		ICU Level of Service				A			
Analysis Period (min)			15									

HCM Unsignalized Intersection Capacity Analysis  
 108: SW Middleton Rd & SW Brookman Rd

02/05/2019



Movement	EBL	EBT	EBR	WBL	WBT	WBR	NBL	NBT	NBR	SBL	SBT	SBR
Lane Configurations		↕			↕			↕			↕	
Traffic Volume (veh/h)	3	94	17	2	60	6	16	11	10	7	4	3
Future Volume (Veh/h)	3	94	17	2	60	6	16	11	10	7	4	3
Sign Control		Stop			Stop			Free			Free	
Grade		-1%			1%			-2%			0%	
Peak Hour Factor	0.72	0.72	0.72	0.72	0.72	0.72	0.72	0.72	0.72	0.72	0.72	0.72
Hourly flow rate (vph)	4	131	24	3	83	8	22	15	14	10	6	4
Pedestrians												
Lane Width (ft)												
Walking Speed (ft/s)												
Percent Blockage												
Right turn flare (veh)												
Median type								None			None	
Median storage (veh)												
Upstream signal (ft)												
pX, platoon unblocked												
vC, conflicting volume	144	101	8	184	96	22	10			29		
vC1, stage 1 conf vol												
vC2, stage 2 conf vol												
vCu, unblocked vol	144	101	8	184	96	22	10			29		
tC, single (s)	7.1	6.5	6.2	7.6	6.6	6.4	4.1			4.1		
tC, 2 stage (s)												
tF (s)	3.5	4.0	3.3	4.0	4.0	3.5	2.2			2.2		
p0 queue free %	99	83	98	99	89	99	99			99		
cM capacity (veh/h)	745	775	1080	573	773	1013	1623			1597		
<b>Direction, Lane #</b>	<b>EB 1</b>	<b>WB 1</b>	<b>NB 1</b>	<b>SB 1</b>								
Volume Total	159	94	51	20								
Volume Left	4	3	22	10								
Volume Right	24	8	14	4								
cSH	809	780	1623	1597								
Volume to Capacity	0.20	0.12	0.01	0.01								
Queue Length 95th (ft)	18	10	1	0								
Control Delay (s)	10.5	10.2	3.2	3.7								
Lane LOS	B	B	A	A								
Approach Delay (s)	10.5	10.2	3.2	3.7								
Approach LOS	B	B										
<b>Intersection Summary</b>												
Average Delay			8.9									
Intersection Capacity Utilization			17.3%		ICU Level of Service					A		
Analysis Period (min)			15									

HCM Unsignalized Intersection Capacity Analysis  
 109: SW Oberst Rd & SW Brookman Rd

02/05/2019



Movement	EBT	EBR	WBL	WBT	NBL	NBR
Lane Configurations	→			←	↘	↙
Traffic Volume (veh/h)	111	3	1	64	3	3
Future Volume (Veh/h)	111	3	1	64	3	3
Sign Control	Free			Free	Stop	
Grade	-3%			2%	1%	
Peak Hour Factor	0.68	0.68	0.68	0.68	0.68	0.68
Hourly flow rate (vph)	163	4	1	94	4	4
Pedestrians				1		
Lane Width (ft)				12.0		
Walking Speed (ft/s)				3.5		
Percent Blockage				0		
Right turn flare (veh)						
Median type	None			None		
Median storage (veh)						
Upstream signal (ft)						
pX, platoon unblocked						
vC, conflicting volume			167			166
vC1, stage 1 conf vol						
vC2, stage 2 conf vol						
vCu, unblocked vol			167			166
tC, single (s)			4.1			6.5
tC, 2 stage (s)						
tF (s)			2.2			3.6
p0 queue free %			100			100
cM capacity (veh/h)			1423			803
Direction, Lane #	EB 1	WB 1	NB 1			
Volume Total	167	95	8			
Volume Left	0	1	4			
Volume Right	4	0	4			
cSH	1700	1423	766			
Volume to Capacity	0.10	0.00	0.01			
Queue Length 95th (ft)	0	0	1			
Control Delay (s)	0.0	0.1	9.8			
Lane LOS			A			
Approach Delay (s)	0.0	0.1	9.8			
Approach LOS			A			
Intersection Summary						
Average Delay			0.3			
Intersection Capacity Utilization			16.4%	ICU Level of Service	A	
Analysis Period (min)			15			

HCM Unsignalized Intersection Capacity Analysis  
 110: SW Ladd Hill Rd & SW Brookman Rd

02/05/2019



Movement	EBL	EBR	NBL	NBT	SBT	SBR
Lane Configurations						
Traffic Volume (veh/h)	98	25	19	112	42	40
Future Volume (Veh/h)	98	25	19	112	42	40
Sign Control	Stop			Free	Free	
Grade	2%			-1%	0%	
Peak Hour Factor	0.70	0.70	0.70	0.70	0.70	0.70
Hourly flow rate (vph)	140	36	27	160	60	57
Pedestrians					1	
Lane Width (ft)					12.0	
Walking Speed (ft/s)					3.5	
Percent Blockage					0	
Right turn flare (veh)						
Median type				None	None	
Median storage (veh)						
Upstream signal (ft)						
pX, platoon unblocked						
vC, conflicting volume	304	88	117			
vC1, stage 1 conf vol						
vC2, stage 2 conf vol						
vCu, unblocked vol	304	88	117			
tC, single (s)	6.4	6.3	4.3			
tC, 2 stage (s)						
tF (s)	3.5	3.4	2.4			
p0 queue free %	79	96	98			
cM capacity (veh/h)	674	953	1383			
<b>Direction, Lane #</b>	<b>EB 1</b>	<b>NB 1</b>	<b>SB 1</b>			
Volume Total	176	187	117			
Volume Left	140	27	0			
Volume Right	36	0	57			
cSH	717	1383	1700			
Volume to Capacity	0.25	0.02	0.07			
Queue Length 95th (ft)	24	1	0			
Control Delay (s)	11.6	1.2	0.0			
Lane LOS	B	A				
Approach Delay (s)	11.6	1.2	0.0			
Approach LOS	B					
<b>Intersection Summary</b>						
Average Delay			4.8			
Intersection Capacity Utilization			27.2%	ICU Level of Service	A	
Analysis Period (min)			15			

HCM Signalized Intersection Capacity Analysis  
 101: SW Pacific Hwy & SW Elwert Rd/SW Sunset Blvd

02/05/2019



Movement	EBL	EBT	EBR	WBL	WBT	WBR	NBL	NBT	NBR	SBL	SBT	SBR
Lane Configurations	↘	↗		↘	↗		↘	↗	↘	↗	↗	↘
Traffic Volume (vph)	45	161	324	135	145	142	244	1034	133	278	1714	45
Future Volume (vph)	45	161	324	135	145	142	244	1034	133	278	1714	45
Ideal Flow (vphpl)	1900	1900	1900	1900	1900	1900	1900	1900	1900	1900	1900	1900
Grade (%)		0%			0%			-1%			2%	
Total Lost time (s)	4.5	6.0		4.5	6.0		5.0	6.0	6.0	5.0	6.0	6.0
Lane Util. Factor	1.00	0.95		1.00	0.95		0.97	0.95	1.00	0.97	0.95	1.00
Frbp, ped/bikes	1.00	1.00		1.00	0.99		1.00	1.00	0.99	1.00	1.00	1.00
Flpb, ped/bikes	1.00	1.00		1.00	1.00		1.00	1.00	1.00	1.00	1.00	1.00
Frnt	1.00	0.90		1.00	0.93		1.00	1.00	0.85	1.00	1.00	0.85
Flt Protected	0.95	1.00		0.95	1.00		0.95	1.00	1.00	0.95	1.00	1.00
Satd. Flow (prot)	1671	3205		1703	3251		3484	3489	1587	3467	3504	1599
Flt Permitted	0.95	1.00		0.95	1.00		0.95	1.00	1.00	0.95	1.00	1.00
Satd. Flow (perm)	1671	3205		1703	3251		3484	3489	1587	3467	3504	1599
Peak-hour factor, PHF	0.94	0.94	0.94	0.94	0.94	0.94	0.94	0.94	0.94	0.94	0.94	0.94
Adj. Flow (vph)	48	171	345	144	154	151	260	1100	141	296	1823	48
RTOR Reduction (vph)	0	125	0	0	114	0	0	0	42	0	0	22
Lane Group Flow (vph)	48	391	0	144	191	0	260	1100	99	296	1823	26
Confl. Peds. (#/hr)	3					3						
Confl. Bikes (#/hr)									1			
Heavy Vehicles (%)	8%	0%	2%	6%	2%	2%	1%	4%	1%	0%	2%	0%
Turn Type	Prot	NA		Prot	NA		Prot	NA	Perm	Prot	NA	Perm
Protected Phases	7	4		3	8		5	2		1	6	
Permitted Phases									2			6
Actuated Green, G (s)	8.0	25.4		13.5	30.9		12.0	77.7	77.7	16.4	82.1	82.1
Effective Green, g (s)	8.0	25.4		13.5	30.9		12.0	77.7	77.7	16.4	82.1	82.1
Actuated g/C Ratio	0.05	0.16		0.09	0.20		0.08	0.50	0.50	0.11	0.53	0.53
Clearance Time (s)	4.5	6.0		4.5	6.0		5.0	6.0	6.0	5.0	6.0	6.0
Vehicle Extension (s)	3.0	3.0		3.0	3.0		3.0	5.4	5.4	3.5	5.4	5.4
Lane Grp Cap (vph)	86	526		148	650		270	1754	798	368	1861	849
v/s Ratio Prot	0.03	c0.12		c0.08	0.06		0.07	0.32		c0.09	c0.52	
v/s Ratio Perm									0.06			0.02
v/c Ratio	0.56	0.92dr		0.97	0.29		0.96	0.63	0.12	0.80	0.98	0.03
Uniform Delay, d1	71.5	61.5		70.3	52.5		71.0	27.9	20.4	67.5	35.4	17.2
Progression Factor	1.00	1.00		1.00	1.00		1.00	1.00	1.00	1.00	1.00	1.00
Incremental Delay, d2	7.6	5.7		65.4	0.3		44.3	1.1	0.2	12.3	16.3	0.0
Delay (s)	79.2	67.1		135.7	52.8		115.4	29.0	20.5	79.8	51.7	17.3
Level of Service	E	E		F	D		F	C	C	E	D	B
Approach Delay (s)		68.1			79.4			43.1			54.8	
Approach LOS		E			E			D			D	

Intersection Summary

HCM 2000 Control Delay	55.0	HCM 2000 Level of Service	E
HCM 2000 Volume to Capacity ratio	0.93		
Actuated Cycle Length (s)	154.5	Sum of lost time (s)	21.5
Intersection Capacity Utilization	94.6%	ICU Level of Service	F
Analysis Period (min)	15		

dr Defacto Right Lane. Recode with 1 though lane as a right lane.

c Critical Lane Group

# HCM Unsignalized Intersection Capacity Analysis

## 102: SW Woodhaven Dr & SW Sunset Blvd

02/05/2019



Movement	EBL	EBT	EBR	WBL	WBT	WBR	NBL	NBT	NBR	SBL	SBT	SBR
Lane Configurations												
Traffic Volume (veh/h)	121	387	26	5	414	72	12	0	1	36	1	64
Future Volume (Veh/h)	121	387	26	5	414	72	12	0	1	36	1	64
Sign Control		Free			Free			Stop			Stop	
Grade		-1%			1%			-2%			0%	
Peak Hour Factor	0.92	0.92	0.92	0.92	0.92	0.92	0.92	0.92	0.92	0.92	0.92	0.92
Hourly flow rate (vph)	132	421	28	5	450	78	13	0	1	39	1	70
Pedestrians												
Lane Width (ft)												
Walking Speed (ft/s)												
Percent Blockage												
Right turn flare (veh)												
Median type		None			None							
Median storage (veh)												
Upstream signal (ft)		648										
pX, platoon unblocked												
vC, conflicting volume	528			449			1216	1223	421	1185	1212	489
vC1, stage 1 conf vol												
vC2, stage 2 conf vol												
vCu, unblocked vol	528			449			1216	1223	421	1185	1212	489
tC, single (s)	4.1			4.1			7.1	6.5	6.2	7.1	6.5	6.2
tC, 2 stage (s)												
tF (s)	2.2			2.2			3.5	4.0	3.3	3.5	4.0	3.3
p0 queue free %	87			100			90	100	100	74	99	88
cM capacity (veh/h)	1044			1122			126	158	637	150	160	579
Direction, Lane #	EB 1	EB 2	EB 3	WB 1	WB 2	NB 1	SB 1					
Volume Total	132	421	28	5	528	14	110					
Volume Left	132	0	0	5	0	13	39					
Volume Right	0	0	28	0	78	1	70					
cSH	1044	1700	1700	1122	1700	133	285					
Volume to Capacity	0.13	0.25	0.02	0.00	0.31	0.10	0.39					
Queue Length 95th (ft)	11	0	0	0	0	9	44					
Control Delay (s)	8.9	0.0	0.0	8.2	0.0	35.1	25.4					
Lane LOS	A			A		E	D					
Approach Delay (s)	2.0			0.1		35.1	25.4					
Approach LOS						E	D					
Intersection Summary												
Average Delay			3.6									
Intersection Capacity Utilization			48.4%			ICU Level of Service			A			
Analysis Period (min)			15									



HCM Unsignalized Intersection Capacity Analysis  
 103: SW Timbrel Ln & SW Sunset Blvd

02/05/2019























Movement	EBT	EBR	WBL	WBT	NBL	NBR
Lane Configurations	↻		↻	↻	↻	
Traffic Volume (veh/h)	314	110	63	403	89	37
Future Volume (Veh/h)	314	110	63	403	89	37
Sign Control	Free			Free	Stop	
Grade	-1%			1%	0%	
Peak Hour Factor	0.91	0.91	0.91	0.91	0.91	0.91
Hourly flow rate (vph)	345	121	69	443	98	41
Pedestrians				1		
Lane Width (ft)				12.0		
Walking Speed (ft/s)				3.5		
Percent Blockage				0		
Right turn flare (veh)						
Median type	None			None		
Median storage (veh)						
Upstream signal (ft)	1264					
pX, platoon unblocked						
vC, conflicting volume			466		986	406
vC1, stage 1 conf vol						
vC2, stage 2 conf vol						
vCu, unblocked vol			466		986	406
tC, single (s)			4.1		6.4	6.2
tC, 2 stage (s)						
tF (s)			2.2		3.5	3.3
p0 queue free %			94		62	94
cM capacity (veh/h)			1090		257	642

Direction, Lane #	EB 1	WB 1	WB 2	NB 1
Volume Total	466	69	443	139
Volume Left	0	69	0	98
Volume Right	121	0	0	41
cSH	1700	1090	1700	312
Volume to Capacity	0.27	0.06	0.26	0.44
Queue Length 95th (ft)	0	5	0	55
Control Delay (s)	0.0	8.5	0.0	25.4
Lane LOS		A		D
Approach Delay (s)	0.0	1.1		25.4
Approach LOS				D

Intersection Summary			
Average Delay		3.7	
Intersection Capacity Utilization	44.1%		ICU Level of Service A
Analysis Period (min)	15		

HCM Unsignalized Intersection Capacity Analysis  
 104: SW Main St/SW Ladd Hill Rd & SW Sunset Blvd

02/05/2019

												
Movement	EBL	EBT	EBR	WBL	WBT	WBR	NBL	NBT	NBR	SBL	SBT	SBR
Lane Configurations												
Sign Control	Stop			Stop			Stop			Stop		
Traffic Volume (vph)	27	133	134	34	103	52	99	226	29	69	368	41
Future Volume (vph)	27	133	134	34	103	52	99	226	29	69	368	41
Peak Hour Factor	0.89	0.89	0.89	0.89	0.89	0.89	0.89	0.89	0.89	0.89	0.89	0.89
Hourly flow rate (vph)	30	149	151	38	116	58	111	254	33	78	413	46
Direction, Lane #	EB 1	EB 2	WB 1	WB 2	NB 1	NB 2	SB 1	SB 2				
Volume Total (vph)	30	300	38	174	111	287	78	459				
Volume Left (vph)	30	0	38	0	111	0	78	0				
Volume Right (vph)	0	151	0	58	0	33	0	46				
Hadj (s)	0.50	-0.33	0.55	-0.22	0.50	-0.04	0.53	-0.05				
Departure Headway (s)	8.2	7.4	8.6	7.8	7.9	7.4	7.7	7.1				
Degree Utilization, x	0.07	0.62	0.09	0.38	0.24	0.59	0.17	0.90				
Capacity (veh/h)	420	460	398	438	436	464	453	501				
Control Delay (s)	10.6	20.3	11.2	14.2	12.2	19.1	11.0	45.1				
Approach Delay (s)	19.5		13.7		17.2		40.2					
Approach LOS	C		B		C		E					
Intersection Summary												
Delay			25.5									
Level of Service			D									
Intersection Capacity Utilization			59.5%		ICU Level of Service		B					
Analysis Period (min)			15									

HCM Unsignalized Intersection Capacity Analysis  
 105: SW Baker Rd/SW Murdock Rd & SW Sunset Blvd

02/05/2019



Movement	EBL	EBT	EBR	WBL	WBT	WBR	NBL	NBT	NBR	SBL	SBT	SBR
Lane Configurations												
Sign Control		Stop			Stop			Stop			Stop	
Traffic Volume (vph)	105	14	165	1	21	16	313	143	6	32	149	273
Future Volume (vph)	105	14	165	1	21	16	313	143	6	32	149	273
Peak Hour Factor	0.90	0.90	0.90	0.90	0.90	0.90	0.90	0.90	0.90	0.90	0.90	0.90
Hourly flow rate (vph)	117	16	183	1	23	18	348	159	7	36	166	303

Direction, Lane #	EB 1	EB 2	WB 1	NB 1	SB 1
Volume Total (vph)	117	199	42	514	505
Volume Left (vph)	117	0	1	348	36
Volume Right (vph)	0	183	18	7	303
Hadj (s)	0.50	-0.57	-0.21	0.16	-0.31
Departure Headway (s)	8.0	6.9	7.8	6.1	5.8
Degree Utilization, x	0.26	0.38	0.09	0.88	0.81
Capacity (veh/h)	431	497	415	568	609
Control Delay (s)	12.6	12.9	11.6	38.1	28.4
Approach Delay (s)	12.8		11.6	38.1	28.4
Approach LOS	B		B	E	D

Intersection Summary

Delay	27.9
Level of Service	D
Intersection Capacity Utilization	74.1%
ICU Level of Service	D
Analysis Period (min)	15

HCM Unsignalized Intersection Capacity Analysis  
 106: SW Pacific Hwy & SW Chapman Rd

02/05/2019



Movement	EBL	EBT	EBR	WBL	WBT	WBR	NBU	NBL	NBT	NBR	SBU	SBL
Lane Configurations		↔			↔			↔	↕			↔
Traffic Volume (veh/h)	20	7	12	40	5	30	1	8	1368	46	2	24
Future Volume (Veh/h)	20	7	12	40	5	30	1	8	1368	46	2	24
Sign Control		Stop			Stop				Free			
Grade		0%			0%				0%			
Peak Hour Factor	0.96	0.96	0.96	0.96	0.96	0.96	0.96	0.96	0.96	0.96	0.96	0.96
Hourly flow rate (vph)	21	7	13	42	5	31	0	8	1425	48	0	25
Pedestrians												
Lane Width (ft)												
Walking Speed (ft/s)												
Percent Blockage												
Right turn flare (veh)												
Median type									Raised			
Median storage (veh)									2			
Upstream signal (ft)												
pX, platoon unblocked							0.00				0.00	
vC, conflicting volume	2997	3724	1092	2624	3744	736	0	2229			0	1473
vC1, stage 1 conf vol	2235	2235		1465	1465							
vC2, stage 2 conf vol	762	1489		1159	2279							
vCu, unblocked vol	2997	3724	1092	2624	3744	736	0	2229			0	1473
tC, single (s)	7.6	6.5	6.9	7.6	6.5	6.9	0.0	4.1			0.0	4.1
tC, 2 stage (s)	6.6	5.5		6.6	5.5							
tF (s)	3.5	4.0	3.3	3.5	4.0	3.3	0.0	2.2			0.0	2.2
p0 queue free %	45	89	94	56	91	92	0	97			0	95
cM capacity (veh/h)	38	65	213	95	58	366	0	237			0	464

Direction, Lane #	EB 1	WB 1	NB 1	NB 2	NB 3	SB 1	SB 2	SB 3	SB 4
Volume Total	41	78	8	950	523	25	1092	1092	44
Volume Left	21	42	8	0	0	25	0	0	0
Volume Right	13	31	0	0	48	0	0	0	44
cSH	57	127	237	1700	1700	464	1700	1700	1700
Volume to Capacity	0.72	0.61	0.03	0.56	0.31	0.05	0.64	0.64	0.03
Queue Length 95th (ft)	76	79	3	0	0	4	0	0	0
Control Delay (s)	161.7	70.2	20.7	0.0	0.0	13.2	0.0	0.0	0.0
Lane LOS	F	F	C			B			
Approach Delay (s)	161.7	70.2	0.1			0.1			
Approach LOS	F	F							

Intersection Summary

Average Delay	3.3
Intersection Capacity Utilization	70.1%
ICU Level of Service	C
Analysis Period (min)	15

HCM Unsignalized Intersection Capacity Analysis  
 106: SW Pacific Hwy & SW Chapman Rd

02/05/2019



Movement	SBT	SBR
Lane Configurations	↑↑	↑
Traffic Volume (veh/h)	2098	42
Future Volume (Veh/h)	2098	42
Sign Control	Free	
Grade	0%	
Peak Hour Factor	0.96	0.96
Hourly flow rate (vph)	2185	44
Pedestrians		
Lane Width (ft)		
Walking Speed (ft/s)		
Percent Blockage		
Right turn flare (veh)		
Median type	Raised	
Median storage veh)	2	
Upstream signal (ft)		
pX, platoon unblocked		
vC, conflicting volume		
vC1, stage 1 conf vol		
vC2, stage 2 conf vol		
vCu, unblocked vol		
tC, single (s)		
tC, 2 stage (s)		
tF (s)		
p0 queue free %		
cM capacity (veh/h)		
Direction, Lane #		

HCM Unsignalized Intersection Capacity Analysis  
 107: SW Old Hwy 99W & SW Brookman Rd

02/05/2019



Movement	EBL	EBT	EBR	WBL	WBT	WBR	NBL	NBT	NBR	SBL	SBT	SBR
Lane Configurations		↕			↕			↕			↕	
Traffic Volume (veh/h)	10	60	1	1	70	2	1	1	2	1	1	1
Future Volume (Veh/h)	10	60	1	1	70	2	1	1	2	1	1	1
Sign Control		Free			Free			Stop			Stop	
Grade		0%			2%			2%			-2%	
Peak Hour Factor	0.82	0.82	0.82	0.82	0.82	0.82	0.82	0.82	0.82	0.82	0.82	0.82
Hourly flow rate (vph)	12	73	1	1	85	2	1	1	2	1	1	1
Pedestrians												
Lane Width (ft)												
Walking Speed (ft/s)												
Percent Blockage												
Right turn flare (veh)												
Median type		None			None							
Median storage (veh)												
Upstream signal (ft)												
pX, platoon unblocked												
vC, conflicting volume	87			74			187	186	74	188	186	86
vC1, stage 1 conf vol												
vC2, stage 2 conf vol												
vCu, unblocked vol	87			74			187	186	74	188	186	86
tC, single (s)	4.1			4.1			7.1	6.5	6.2	7.1	6.5	6.2
tC, 2 stage (s)												
tF (s)	2.2			2.2			3.5	4.0	3.3	3.5	4.0	3.3
p0 queue free %	99			100			100	100	100	100	100	100
cM capacity (veh/h)	1522			1538			771	705	994	769	706	978
<b>Direction, Lane #</b>	<b>EB 1</b>	<b>WB 1</b>	<b>NB 1</b>	<b>SB 1</b>								
Volume Total	86	88	4	3								
Volume Left	12	1	1	1								
Volume Right	1	2	2	1								
cSH	1522	1538	846	803								
Volume to Capacity	0.01	0.00	0.00	0.00								
Queue Length 95th (ft)	1	0	0	0								
Control Delay (s)	1.1	0.1	9.3	9.5								
Lane LOS	A	A	A	A								
Approach Delay (s)	1.1	0.1	9.3	9.5								
Approach LOS			A	A								
<b>Intersection Summary</b>												
Average Delay			0.9									
Intersection Capacity Utilization			19.5%		ICU Level of Service				A			
Analysis Period (min)			15									

HCM Unsignalized Intersection Capacity Analysis  
 108: SW Middleton Rd & SW Brookman Rd

02/05/2019



Movement	EBL	EBT	EBR	WBL	WBT	WBR	NBL	NBT	NBR	SBL	SBT	SBR
Lane Configurations		↕			↕			↕			↕	
Traffic Volume (veh/h)	10	42	16	12	50	3	15	6	8	2	10	4
Future Volume (Veh/h)	10	42	16	12	50	3	15	6	8	2	10	4
Sign Control		Stop			Stop			Free			Free	
Grade		-1%			1%			-2%			0%	
Peak Hour Factor	0.74	0.74	0.74	0.74	0.74	0.74	0.74	0.74	0.74	0.74	0.74	0.74
Hourly flow rate (vph)	14	57	22	16	68	4	20	8	11	3	14	5
Pedestrians		1			1						1	
Lane Width (ft)		12.0			12.0						12.0	
Walking Speed (ft/s)		3.5			3.5						3.5	
Percent Blockage		0			0						0	
Right turn flare (veh)												
Median type								None			None	
Median storage (veh)												
Upstream signal (ft)												
pX, platoon unblocked												
vC, conflicting volume	116	84	18	128	80	16	20			20		
vC1, stage 1 conf vol												
vC2, stage 2 conf vol												
vCu, unblocked vol	116	84	18	128	80	16	20			20		
tC, single (s)	7.1	6.5	6.2	7.2	6.5	6.2	4.2			4.1		
tC, 2 stage (s)												
tF (s)	3.5	4.0	3.3	3.6	4.0	3.3	2.3			2.2		
p0 queue free %	98	93	98	98	91	100	99			100		
cM capacity (veh/h)	794	797	1066	758	800	1068	1514			1608		
<b>Direction, Lane #</b>	<b>EB 1</b>	<b>WB 1</b>	<b>NB 1</b>	<b>SB 1</b>								
Volume Total	93	88	39	22								
Volume Left	14	16	20	3								
Volume Right	22	4	11	5								
cSH	847	801	1514	1608								
Volume to Capacity	0.11	0.11	0.01	0.00								
Queue Length 95th (ft)	9	9	1	0								
Control Delay (s)	9.8	10.0	3.8	1.0								
Lane LOS	A	B	A	A								
Approach Delay (s)	9.8	10.0	3.8	1.0								
Approach LOS	A	B										
<b>Intersection Summary</b>												
Average Delay			8.1									
Intersection Capacity Utilization			17.1%		ICU Level of Service				A			
Analysis Period (min)			15									

HCM Unsignalized Intersection Capacity Analysis  
 109: SW Oberst Rd & SW Brookman Rd

02/05/2019



Movement	EBT	EBR	WBL	WBT	NBL	NBR
Lane Configurations	→			←	↘	↙
Traffic Volume (veh/h)	51	0	4	67	4	4
Future Volume (Veh/h)	51	0	4	67	4	4
Sign Control	Free			Free	Stop	
Grade	-3%			2%	1%	
Peak Hour Factor	0.69	0.69	0.69	0.69	0.69	0.69
Hourly flow rate (vph)	74	0	6	97	6	6
Pedestrians						
Lane Width (ft)						
Walking Speed (ft/s)						
Percent Blockage						
Right turn flare (veh)						
Median type	None			None		
Median storage (veh)						
Upstream signal (ft)						
pX, platoon unblocked						
vC, conflicting volume			74		183	74
vC1, stage 1 conf vol						
vC2, stage 2 conf vol						
vCu, unblocked vol			74		183	74
tC, single (s)			4.1		6.7	6.5
tC, 2 stage (s)						
tF (s)			2.2		3.7	3.5
p0 queue free %			100		99	99
cM capacity (veh/h)			1538		754	927
Direction, Lane #	EB 1	WB 1	NB 1			
Volume Total	74	103	12			
Volume Left	0	6	6			
Volume Right	0	0	6			
cSH	1700	1538	831			
Volume to Capacity	0.04	0.00	0.01			
Queue Length 95th (ft)	0	0	1			
Control Delay (s)	0.0	0.5	9.4			
Lane LOS		A	A			
Approach Delay (s)	0.0	0.5	9.4			
Approach LOS			A			
Intersection Summary						
Average Delay			0.8			
Intersection Capacity Utilization			16.8%	ICU Level of Service	A	
Analysis Period (min)			15			



# HCM Unsignalized Intersection Capacity Analysis

## 110: SW Ladd Hill Rd & SW Brookman Rd

02/05/2019



Movement	EBL	EBR	NBL	NBT	SBT	SBR
Lane Configurations						
Traffic Volume (veh/h)	35	16	10	86	95	55
Future Volume (Veh/h)	35	16	10	86	95	55
Sign Control	Stop			Free	Free	
Grade	2%			-1%	0%	
Peak Hour Factor	0.78	0.78	0.78	0.78	0.78	0.78
Hourly flow rate (vph)	45	21	13	110	122	71
<b>Pedestrians</b>						
Lane Width (ft)						
Walking Speed (ft/s)						
Percent Blockage						
Right turn flare (veh)						
Median type				None	None	
Median storage (veh)						
Upstream signal (ft)						
pX, platoon unblocked						
vC, conflicting volume	294	158	193			
vC1, stage 1 conf vol						
vC2, stage 2 conf vol						
vCu, unblocked vol	294	158	193			
tC, single (s)	6.4	6.3	4.1			
tC, 2 stage (s)						
tF (s)	3.5	3.4	2.2			
p0 queue free %	93	98	99			
cM capacity (veh/h)	689	875	1392			
<b>Direction, Lane #</b>	<b>EB 1</b>	<b>NB 1</b>	<b>SB 1</b>			
Volume Total	66	123	193			
Volume Left	45	13	0			
Volume Right	21	0	71			
cSH	739	1392	1700			
Volume to Capacity	0.09	0.01	0.11			
Queue Length 95th (ft)	7	1	0			
Control Delay (s)	10.4	0.9	0.0			
Lane LOS	B	A				
Approach Delay (s)	10.4	0.9	0.0			
Approach LOS	B					
<b>Intersection Summary</b>						
Average Delay			2.1			
Intersection Capacity Utilization			22.9%	ICU Level of Service	A	
Analysis Period (min)			15			

Appendix G Total Traffic Conditions  
Level of Service Worksheets

HCM Signalized Intersection Capacity Analysis  
 101: SW Pacific Hwy & SW Elwert Rd/SW Sunset Blvd

02/05/2019



Movement	EBL	EBT	EBR	WBL	WBT	WBR	NBL	NBT	NBR	SBL	SBT	SBR
Lane Configurations	↗	↗↘		↗	↗↘		↗↘	↗↘	↗	↗↘	↗↘	↗
Traffic Volume (vph)	131	237	281	108	387	219	335	1609	112	130	766	194
Future Volume (vph)	131	237	281	108	387	219	335	1609	112	130	766	194
Ideal Flow (vphpl)	1900	1900	1900	1900	1900	1900	1900	1900	1900	1900	1900	1900
Grade (%)		0%			0%			-1%				2%
Total Lost time (s)	4.5	6.0		4.5	6.0		5.0	6.0	6.0	5.0	6.0	6.0
Lane Util. Factor	1.00	0.95		1.00	0.95		0.97	0.95	1.00	0.97	0.95	1.00
Frpb, ped/bikes	1.00	1.00		1.00	1.00		1.00	1.00	1.00	1.00	1.00	0.98
Flpb, ped/bikes	1.00	1.00		1.00	1.00		1.00	1.00	1.00	1.00	1.00	1.00
Frt	1.00	0.92		1.00	0.95		1.00	1.00	0.85	1.00	1.00	0.85
Flt Protected	0.95	1.00		0.95	1.00		0.95	1.00	1.00	0.95	1.00	1.00
Satd. Flow (prot)	1805	3208		1770	3303		3417	3489	1561	3180	3279	1505
Flt Permitted	0.95	1.00		0.95	1.00		0.95	1.00	1.00	0.95	1.00	1.00
Satd. Flow (perm)	1805	3208		1770	3303		3417	3489	1561	3180	3279	1505
Peak-hour factor, PHF	0.95	0.95	0.95	0.95	0.95	0.95	0.95	0.95	0.95	0.95	0.95	0.95
Adj. Flow (vph)	138	249	296	114	407	231	353	1694	118	137	806	204
RTOR Reduction (vph)	0	137	0	0	50	0	0	0	43	0	0	114
Lane Group Flow (vph)	138	408	0	114	588	0	353	1694	75	137	806	90
Confl. Bikes (#/hr)												1
Heavy Vehicles (%)	0%	5%	2%	2%	3%	4%	3%	4%	4%	9%	9%	4%
Turn Type	Prot	NA		Prot	NA		Prot	NA	Perm	Prot	NA	Perm
Protected Phases	7	4		3	8		5	2		1	6	
Permitted Phases									2			6
Actuated Green, G (s)	13.5	33.6		12.8	32.9		19.5	77.2	77.2	11.7	69.4	69.4
Effective Green, g (s)	13.5	33.6		12.8	32.9		19.5	77.2	77.2	11.7	69.4	69.4
Actuated g/C Ratio	0.09	0.21		0.08	0.21		0.12	0.49	0.49	0.07	0.44	0.44
Clearance Time (s)	4.5	6.0		4.5	6.0		5.0	6.0	6.0	5.0	6.0	6.0
Vehicle Extension (s)	3.0	3.0		3.0	3.0		3.0	5.4	5.4	3.5	5.4	5.4
Lane Grp Cap (vph)	155	687		144	693		424	1717	768	237	1451	666
v/s Ratio Prot	c0.08	0.13		0.06	c0.18		c0.10	c0.49		0.04	0.25	
v/s Ratio Perm									0.05			0.06
v/c Ratio	0.89	0.59		0.79	0.85		0.83	0.99	0.10	0.58	0.56	0.14
Uniform Delay, d1	70.9	55.5		70.7	59.6		67.1	39.3	21.2	70.2	32.3	25.9
Progression Factor	1.00	1.00		1.00	1.00		1.00	1.00	1.00	1.00	1.00	1.00
Incremental Delay, d2	42.0	1.4		25.0	9.5		13.1	18.6	0.1	3.7	0.9	0.2
Delay (s)	112.9	56.8		95.7	69.1		80.1	57.9	21.4	73.8	33.2	26.1
Level of Service	F	E		F	E		F	E	C	E	C	C
Approach Delay (s)		68.2			73.1			59.5			36.8	
Approach LOS		E			E			E			D	

Intersection Summary

HCM 2000 Control Delay	57.4	HCM 2000 Level of Service	E
HCM 2000 Volume to Capacity ratio	0.94		
Actuated Cycle Length (s)	156.8	Sum of lost time (s)	21.5
Intersection Capacity Utilization	91.1%	ICU Level of Service	F
Analysis Period (min)	15		
c Critical Lane Group			

HCM Unsignalized Intersection Capacity Analysis  
 102: SW Woodhaven Dr & SW Sunset Blvd

02/05/2019



Movement	EBL	EBT	EBR	WBL	WBT	WBR	NBL	NBT	NBR	SBL	SBT	SBR
Lane Configurations												
Traffic Volume (veh/h)	55	339	74	7	562	91	20	15	11	29	47	119
Future Volume (Veh/h)	55	339	74	7	562	91	20	15	11	29	47	119
Sign Control		Free			Free			Stop			Stop	
Grade		-1%			1%			-2%			0%	
Peak Hour Factor	0.80	0.80	0.80	0.80	0.80	0.80	0.80	0.80	0.80	0.80	0.80	0.80
Hourly flow rate (vph)	69	424	93	9	703	114	25	19	14	36	59	149
Pedestrians					5							3
Lane Width (ft)					12.0							12.0
Walking Speed (ft/s)					3.5							3.5
Percent Blockage					0							0
Right turn flare (veh)												
Median type		None			None							
Median storage (veh)												
Upstream signal (ft)		648										
pX, platoon unblocked				0.91			0.91	0.91	0.91	0.91	0.91	0.91
vC, conflicting volume	820			517			1462	1400	429	1372	1436	763
vC1, stage 1 conf vol												
vC2, stage 2 conf vol												
vCu, unblocked vol	820			422			1458	1390	325	1359	1430	763
tC, single (s)	4.2			4.2			7.1	6.5	6.2	7.2	6.5	6.2
tC, 2 stage (s)												
tF (s)	2.3			2.3			3.5	4.0	3.3	3.6	4.0	3.3
p0 queue free %	91			99			27	84	98	59	47	63
cM capacity (veh/h)	781			981			34	118	654	88	112	406
<b>Direction, Lane #</b>	<b>EB 1</b>	<b>EB 2</b>	<b>EB 3</b>	<b>WB 1</b>	<b>WB 2</b>	<b>NB 1</b>	<b>SB 1</b>					
Volume Total	69	424	93	9	817	58	244					
Volume Left	69	0	0	9	0	25	36					
Volume Right	0	0	93	0	114	14	149					
cSH	781	1700	1700	981	1700	63	187					
Volume to Capacity	0.09	0.25	0.05	0.01	0.48	0.92	1.30					
Queue Length 95th (ft)	7	0	0	1	0	109	344					
Control Delay (s)	10.1	0.0	0.0	8.7	0.0	197.0	218.8					
Lane LOS	B			A		F	F					
Approach Delay (s)	1.2			0.1		197.0	218.8					
Approach LOS						F	F					
<b>Intersection Summary</b>												
Average Delay			38.3									
Intersection Capacity Utilization			60.4%		ICU Level of Service		B					
Analysis Period (min)			15									

HCM Unsignalized Intersection Capacity Analysis  
 103: SW Timbrel Ln & SW Sunset Blvd

02/05/2019



Movement	EBT	EBR	WBL	WBT	NBL	NBR
Lane Configurations	↻		↻	↻	↻	
Traffic Volume (veh/h)	303	75	75	462	198	48
Future Volume (Veh/h)	303	75	75	462	198	48
Sign Control	Free			Free	Stop	
Grade	-1%			1%	0%	
Peak Hour Factor	0.84	0.84	0.84	0.84	0.84	0.84
Hourly flow rate (vph)	361	89	89	550	236	57
Pedestrians				21	1	
Lane Width (ft)				12.0	12.0	
Walking Speed (ft/s)				3.5	3.5	
Percent Blockage				2	0	
Right turn flare (veh)						
Median type	None			None		
Median storage (veh)						
Upstream signal (ft)	1264					
pX, platoon unblocked						
vC, conflicting volume			451	1134		428
vC1, stage 1 conf vol						
vC2, stage 2 conf vol						
vCu, unblocked vol			451	1134		428
tC, single (s)			4.2	6.4		6.3
tC, 2 stage (s)						
tF (s)			2.3	3.5		3.4
p0 queue free %			92	0		91
cM capacity (veh/h)			1088	203		604

Direction, Lane #	EB 1	WB 1	WB 2	NB 1
Volume Total	450	89	550	293
Volume Left	0	89	0	236
Volume Right	89	0	0	57
cSH	1700	1088	1700	233
Volume to Capacity	0.26	0.08	0.32	1.26
Queue Length 95th (ft)	0	7	0	373
Control Delay (s)	0.0	8.6	0.0	189.1
Lane LOS	A		F	
Approach Delay (s)	0.0	1.2	189.1	
Approach LOS	F			

Intersection Summary			
Average Delay	40.6		
Intersection Capacity Utilization	49.0%	ICU Level of Service	A
Analysis Period (min)	15		

HCM Unsignalized Intersection Capacity Analysis  
 104: SW Main St/SW Ladd Hill Rd & SW Sunset Blvd

02/05/2019



Movement	EBL	EBT	EBR	WBL	WBT	WBR	NBL	NBT	NBR	SBL	SBT	SBR
Lane Configurations												
Sign Control	Stop			Stop			Stop			Stop		
Traffic Volume (vph)	112	311	39	37	265	32	89	143	85	30	42	107
Future Volume (vph)	112	311	39	37	265	32	89	143	85	30	42	107
Peak Hour Factor	0.90	0.90	0.90	0.90	0.90	0.90	0.90	0.90	0.90	0.90	0.90	0.90
Hourly flow rate (vph)	124	346	43	41	294	36	99	159	94	33	47	119

Direction, Lane #	EB 1	EB 2	WB 1	WB 2	NB 1	NB 2	SB 1	SB 2
Volume Total (vph)	124	389	41	330	99	253	33	166
Volume Left (vph)	124	0	41	0	99	0	33	0
Volume Right (vph)	0	43	0	36	0	94	0	119
Hadj (s)	0.58	-0.05	0.72	-0.05	0.55	-0.20	0.50	-0.45
Departure Headway (s)	7.6	7.0	7.9	7.2	8.0	7.3	8.3	7.4
Degree Utilization, x	0.26	0.75	0.09	0.66	0.22	0.51	0.08	0.34
Capacity (veh/h)	455	502	433	481	426	463	399	452
Control Delay (s)	12.1	27.0	10.5	21.7	12.1	16.5	10.8	12.9
Approach Delay (s)	23.4		20.4		15.3		12.6	
Approach LOS	C		C		C		B	

Intersection Summary

Delay	19.1
Level of Service	C
Intersection Capacity Utilization	54.6%
ICU Level of Service	A
Analysis Period (min)	15

HCM Unsignalized Intersection Capacity Analysis  
 105: SW Baker Rd/SW Murdock Rd & SW Sunset Blvd

02/05/2019



Movement	EBL	EBT	EBR	WBL	WBT	WBR	NBL	NBT	NBR	SBL	SBT	SBR
Lane Configurations												
Sign Control	Stop				Stop			Stop			Stop	
Traffic Volume (vph)	280	9	227	5	23	24	141	141	3	5	116	105
Future Volume (vph)	280	9	227	5	23	24	141	141	3	5	116	105
Peak Hour Factor	0.91	0.91	0.91	0.91	0.91	0.91	0.91	0.91	0.91	0.91	0.91	0.91
Hourly flow rate (vph)	308	10	249	5	25	26	155	155	3	5	127	115

Direction, Lane #	EB 1	EB 2	WB 1	NB 1	SB 1
Volume Total (vph)	308	259	56	313	247
Volume Left (vph)	308	0	5	155	5
Volume Right (vph)	0	249	26	3	115
Hadj (s)	0.55	-0.60	-0.19	0.21	-0.16
Departure Headway (s)	6.9	5.7	6.6	6.2	6.0
Degree Utilization, x	0.59	0.41	0.10	0.54	0.41
Capacity (veh/h)	506	607	458	549	562
Control Delay (s)	18.0	11.4	10.3	16.2	13.1
Approach Delay (s)	15.0		10.3	16.2	13.1
Approach LOS	C		B	C	B

Intersection Summary

Delay	14.7
Level of Service	B
Intersection Capacity Utilization	60.4%
ICU Level of Service	B
Analysis Period (min)	15

HCM Unsignalized Intersection Capacity Analysis  
 106: SW Pacific Hwy & SW Chapman Rd

02/05/2019



Movement	EBL	EBT	EBR	WBL	WBT	WBR	NBU	NBL	NBT	NBR	SBU	SBL
Lane Configurations		↕			↕			↕	↕			↕
Traffic Volume (veh/h)	30	3	2	47	3	93	4	8	1914	92	3	38
Future Volume (Veh/h)	30	3	2	47	3	93	4	8	1914	92	3	38
Sign Control		Stop			Stop				Free			
Grade		0%			0%				0%			
Peak Hour Factor	0.96	0.96	0.96	0.96	0.96	0.96	0.96	0.96	0.96	0.96	0.96	0.96
Hourly flow rate (vph)	31	3	2	49	3	97	0	8	1994	96	0	40
Pedestrians												
Lane Width (ft)												
Walking Speed (ft/s)												
Percent Blockage												
Right turn flare (veh)												
Median type												
Median storage veh												
Upstream signal (ft)												
pX, platoon unblocked							0.00				0.00	
vC, conflicting volume	2344	3338	576	2718	3307	1045	0	1169			0	2090
vC1, stage 1 conf vol	1232	1232		2058	2058							
vC2, stage 2 conf vol	1112	2106		660	1249							
vCu, unblocked vol	2344	3338	576	2718	3307	1045	0	1169			0	2090
tC, single (s)	7.7	6.5	6.9	7.6	6.5	7.2	0.0	4.1			0.0	4.1
tC, 2 stage (s)	6.7	5.5		6.6	5.5							
tF (s)	3.6	4.0	3.3	3.5	4.0	3.4	0.0	2.2			0.0	2.2
p0 queue free %	47	94	100	5	96	53	0	99			0	85
cM capacity (veh/h)	58	49	466	52	84	207	0	605			0	268
Direction, Lane #												
	EB 1	WB 1	NB 1	NB 2	NB 3	SB 1	SB 2	SB 3	SB 4			
Volume Total	36	149	8	1329	761	40	576	576	17			
Volume Left	31	49	8	0	0	40	0	0	0			
Volume Right	2	97	0	0	96	0	0	0	17			
cSH	60	103	605	1700	1700	268	1700	1700	1700			
Volume to Capacity	0.60	1.45	0.01	0.78	0.45	0.15	0.34	0.34	0.01			
Queue Length 95th (ft)	62	273	1	0	0	13	0	0	0			
Control Delay (s)	130.5	323.8	11.0	0.0	0.0	20.8	0.0	0.0	0.0			
Lane LOS	F	F	B			C						
Approach Delay (s)	130.5	323.8	0.0			0.7						
Approach LOS	F	F										
Intersection Summary												
Average Delay			15.4									
Intersection Capacity Utilization			70.5%		ICU Level of Service				C			
Analysis Period (min)			15									



HCM Unsignalized Intersection Capacity Analysis  
 106: SW Pacific Hwy & SW Chapman Rd

02/05/2019



Movement	SBT	SBR
Lane Configurations	↑↑	↑
Traffic Volume (veh/h)	1106	16
Future Volume (Veh/h)	1106	16
Sign Control	Free	
Grade	0%	
Peak Hour Factor	0.96	0.96
Hourly flow rate (vph)	1152	17
Pedestrians		
Lane Width (ft)		
Walking Speed (ft/s)		
Percent Blockage		
Right turn flare (veh)		
Median type	Raised	
Median storage (veh)	2	
Upstream signal (ft)		
pX, platoon unblocked		
vC, conflicting volume		
vC1, stage 1 conf vol		
vC2, stage 2 conf vol		
vCu, unblocked vol		
tC, single (s)		
tC, 2 stage (s)		
tF (s)		
p0 queue free %		
cM capacity (veh/h)		
Direction, Lane #		

HCM Unsignalized Intersection Capacity Analysis  
 107: SW Old Hwy 99W & SW Brookman Rd

02/05/2019



Movement	EBL	EBT	EBR	WBL	WBT	WBR	NBL	NBT	NBR	SBL	SBT	SBR
Lane Configurations		↕			↕			↕			↕	
Traffic Volume (veh/h)	11	120	2	0	122	3	3	2	2	8	3	15
Future Volume (Veh/h)	11	120	2	0	122	3	3	2	2	8	3	15
Sign Control		Free			Free			Stop			Stop	
Grade		0%			2%			2%			-2%	
Peak Hour Factor	0.69	0.69	0.69	0.69	0.69	0.69	0.69	0.69	0.69	0.69	0.69	0.69
Hourly flow rate (vph)	16	174	3	0	177	4	4	3	3	12	4	22
Pedestrians												
Lane Width (ft)												
Walking Speed (ft/s)												
Percent Blockage												
Right turn flare (veh)												
Median type		None			None							
Median storage (veh)												
Upstream signal (ft)												
pX, platoon unblocked												
vC, conflicting volume	181			177			410	388	176	391	388	179
vC1, stage 1 conf vol												
vC2, stage 2 conf vol												
vCu, unblocked vol	181			177			410	388	176	391	388	179
tC, single (s)	4.1			4.1			7.6	7.0	6.2	7.1	6.5	6.4
tC, 2 stage (s)												
tF (s)	2.2			2.2			4.0	4.5	3.3	3.5	4.0	3.5
p0 queue free %	99			100			99	99	100	98	99	97
cM capacity (veh/h)	1407			1411			456	473	873	562	544	817
Direction, Lane #												
	EB 1	WB 1	NB 1	SB 1								
Volume Total	193	181	10	38								
Volume Left	16	0	4	12								
Volume Right	3	4	3	22								
cSH	1407	1411	539	683								
Volume to Capacity	0.01	0.00	0.02	0.06								
Queue Length 95th (ft)	1	0	1	4								
Control Delay (s)	0.7	0.0	11.8	10.6								
Lane LOS	A		B	B								
Approach Delay (s)	0.7	0.0	11.8	10.6								
Approach LOS			B	B								
Intersection Summary												
Average Delay			1.6									
Intersection Capacity Utilization			25.6%		ICU Level of Service				A			
Analysis Period (min)			15									

HCM Unsignalized Intersection Capacity Analysis  
 108: SW Middleton Rd & SW Brookman Rd

02/05/2019



Movement	EBL	EBT	EBR	WBL	WBT	WBR	NBL	NBT	NBR	SBL	SBT	SBR
Lane Configurations		↕			↕			↕			↕	
Traffic Volume (veh/h)	3	110	17	2	110	6	16	11	10	9	4	3
Future Volume (Veh/h)	3	110	17	2	110	6	16	11	10	9	4	3
Sign Control		Stop			Stop			Free			Free	
Grade		-1%			1%			-2%			0%	
Peak Hour Factor	0.72	0.72	0.72	0.72	0.72	0.72	0.72	0.72	0.72	0.72	0.72	0.72
Hourly flow rate (vph)	4	153	24	3	153	8	22	15	14	13	6	4
Pedestrians												
Lane Width (ft)												
Walking Speed (ft/s)												
Percent Blockage												
Right turn flare (veh)												
Median type								None			None	
Median storage (veh)												
Upstream signal (ft)												
pX, platoon unblocked												
vC, conflicting volume	184	107	8	200	102	22	10			29		
vC1, stage 1 conf vol												
vC2, stage 2 conf vol												
vCu, unblocked vol	184	107	8	200	102	22	10			29		
tC, single (s)	7.1	6.5	6.2	7.6	6.6	6.4	4.1			4.1		
tC, 2 stage (s)												
tF (s)	3.5	4.0	3.3	4.0	4.0	3.5	2.2			2.2		
p0 queue free %	99	80	98	99	80	99	99			99		
cM capacity (veh/h)	645	768	1080	542	765	1013	1623			1597		
<b>Direction, Lane #</b>	<b>EB 1</b>	<b>WB 1</b>	<b>NB 1</b>	<b>SB 1</b>								
Volume Total	181	164	51	23								
Volume Left	4	3	22	13								
Volume Right	24	8	14	4								
cSH	795	769	1623	1597								
Volume to Capacity	0.23	0.21	0.01	0.01								
Queue Length 95th (ft)	22	20	1	1								
Control Delay (s)	10.9	10.9	3.2	4.1								
Lane LOS	B	B	A	A								
Approach Delay (s)	10.9	10.9	3.2	4.1								
Approach LOS	B	B										
<b>Intersection Summary</b>												
Average Delay			9.6									
Intersection Capacity Utilization			18.5%		ICU Level of Service				A			
Analysis Period (min)			15									

HCM Unsignalized Intersection Capacity Analysis  
 109: SW Oberst Rd/Site Access & SW Brookman Rd

02/05/2019



Movement	EBL	EBT	EBR	WBL	WBT	WBR	NBL	NBT	NBR	SBL	SBT	SBR
Lane Configurations		↕			↕			↕			↕	
Traffic Volume (veh/h)	18	111	3	1	64	12	3	0	3	35	0	50
Future Volume (Veh/h)	18	111	3	1	64	12	3	0	3	35	0	50
Sign Control		Free			Free			Stop			Stop	
Grade		-3%			2%			1%			0%	
Peak Hour Factor	0.68	0.68	0.68	0.68	0.68	0.68	0.68	0.68	0.68	0.68	0.68	0.68
Hourly flow rate (vph)	26	163	4	1	94	18	4	0	4	51	0	74
Pedestrians					1						2	
Lane Width (ft)					12.0						12.0	
Walking Speed (ft/s)					3.5						3.5	
Percent Blockage					0						0	
Right turn flare (veh)												
Median type		None			None							
Median storage (veh)												
Upstream signal (ft)												
pX, platoon unblocked												
vC, conflicting volume	114			167			396	333	166	329	326	105
vC1, stage 1 conf vol												
vC2, stage 2 conf vol												
vCu, unblocked vol	114			167			396	333	166	329	326	105
tC, single (s)	4.1			4.1			7.1	6.5	6.5	7.1	6.5	6.2
tC, 2 stage (s)												
tF (s)	2.2			2.2			3.5	4.0	3.6	3.5	4.0	3.3
p0 queue free %	98			100			99	100	100	92	100	92
cM capacity (veh/h)	1485			1423			515	578	803	614	584	953
<b>Direction, Lane #</b>	<b>EB 1</b>	<b>WB 1</b>	<b>NB 1</b>	<b>SB 1</b>								
Volume Total	193	113	8	125								
Volume Left	26	1	4	51								
Volume Right	4	18	4	74								
cSH	1485	1423	628	778								
Volume to Capacity	0.02	0.00	0.01	0.16								
Queue Length 95th (ft)	1	0	1	14								
Control Delay (s)	1.1	0.1	10.8	10.5								
Lane LOS	A	A	B	B								
Approach Delay (s)	1.1	0.1	10.8	10.5								
Approach LOS			B	B								
<b>Intersection Summary</b>												
Average Delay			3.7									
Intersection Capacity Utilization			26.2%		ICU Level of Service				A			
Analysis Period (min)			15									

# HCM Unsignalized Intersection Capacity Analysis

## 110: SW Ladd Hill Rd & SW Brookman Rd

02/05/2019



Movement	EBL	EBR	NBL	NBT	SBT	SBR
Lane Configurations						
Traffic Volume (veh/h)	122	34	22	112	42	49
Future Volume (Veh/h)	122	34	22	112	42	49
Sign Control	Stop			Free	Free	
Grade	2%			-1%	0%	
Peak Hour Factor	0.70	0.70	0.70	0.70	0.70	0.70
Hourly flow rate (vph)	174	49	31	160	60	70
Pedestrians					1	
Lane Width (ft)					12.0	
Walking Speed (ft/s)					3.5	
Percent Blockage					0	
Right turn flare (veh)						
Median type				None	None	
Median storage (veh)						
Upstream signal (ft)						
pX, platoon unblocked						
vC, conflicting volume	318	95	130			
vC1, stage 1 conf vol						
vC2, stage 2 conf vol						
vCu, unblocked vol	318	95	130			
tC, single (s)	6.4	6.3	4.3			
tC, 2 stage (s)						
tF (s)	3.5	3.4	2.4			
p0 queue free %	74	95	98			
cM capacity (veh/h)	659	945	1368			
<b>Direction, Lane #</b>	<b>EB 1</b>	<b>NB 1</b>	<b>SB 1</b>			
Volume Total	223	191	130			
Volume Left	174	31	0			
Volume Right	49	0	70			
cSH	706	1368	1700			
Volume to Capacity	0.32	0.02	0.08			
Queue Length 95th (ft)	34	2	0			
Control Delay (s)	12.4	1.4	0.0			
Lane LOS	B	A				
Approach Delay (s)	12.4	1.4	0.0			
Approach LOS	B					
<b>Intersection Summary</b>						
Average Delay			5.6			
Intersection Capacity Utilization			29.3%	ICU Level of Service	A	
Analysis Period (min)			15			

HCM Signalized Intersection Capacity Analysis  
 101: SW Pacific Hwy & SW Elwert Rd/SW Sunset Blvd

02/05/2019



Movement	EBL	EBT	EBR	WBL	WBT	WBR	NBL	NBT	NBR	SBL	SBT	SBR
Lane Configurations												
Traffic Volume (vph)	45	161	328	135	145	143	247	1056	133	281	1750	45
Future Volume (vph)	45	161	328	135	145	143	247	1056	133	281	1750	45
Ideal Flow (vphpl)	1900	1900	1900	1900	1900	1900	1900	1900	1900	1900	1900	1900
Grade (%)		0%			0%			-1%				2%
Total Lost time (s)	4.5	6.0		4.5	6.0		5.0	6.0	6.0	5.0	6.0	6.0
Lane Util. Factor	1.00	0.95		1.00	0.95		0.97	0.95	1.00	0.97	0.95	1.00
Frbp, ped/bikes	1.00	1.00		1.00	0.99		1.00	1.00	0.99	1.00	1.00	1.00
Flpb, ped/bikes	1.00	1.00		1.00	1.00		1.00	1.00	1.00	1.00	1.00	1.00
Frnt	1.00	0.90		1.00	0.93		1.00	1.00	0.85	1.00	1.00	0.85
Flt Protected	0.95	1.00		0.95	1.00		0.95	1.00	1.00	0.95	1.00	1.00
Satd. Flow (prot)	1671	3204		1703	3250		3484	3489	1587	3467	3504	1599
Flt Permitted	0.95	1.00		0.95	1.00		0.95	1.00	1.00	0.95	1.00	1.00
Satd. Flow (perm)	1671	3204		1703	3250		3484	3489	1587	3467	3504	1599
Peak-hour factor, PHF	0.94	0.94	0.94	0.94	0.94	0.94	0.94	0.94	0.94	0.94	0.94	0.94
Adj. Flow (vph)	48	171	349	144	154	152	263	1123	141	299	1862	48
RTOR Reduction (vph)	0	125	0	0	116	0	0	0	42	0	0	23
Lane Group Flow (vph)	48	395	0	144	190	0	263	1123	99	299	1862	25
Confl. Peds. (#/hr)	3					3						
Confl. Bikes (#/hr)									1			
Heavy Vehicles (%)	8%	0%	2%	6%	2%	2%	1%	4%	1%	0%	2%	0%
Turn Type	Prot	NA		Prot	NA		Prot	NA	Perm	Prot	NA	Perm
Protected Phases	7	4		3	8		5	2		1	6	
Permitted Phases									2			6
Actuated Green, G (s)	8.0	25.4		13.5	30.9		12.0	75.7	75.7	16.4	80.1	80.1
Effective Green, g (s)	8.0	25.4		13.5	30.9		12.0	75.7	75.7	16.4	80.1	80.1
Actuated g/C Ratio	0.05	0.17		0.09	0.20		0.08	0.50	0.50	0.11	0.53	0.53
Clearance Time (s)	4.5	6.0		4.5	6.0		5.0	6.0	6.0	5.0	6.0	6.0
Vehicle Extension (s)	3.0	3.0		3.0	3.0		3.0	5.4	5.4	3.5	5.4	5.4
Lane Grp Cap (vph)	87	533		150	658		274	1731	787	372	1840	839
v/s Ratio Prot	0.03	c0.12		c0.08	0.06		0.08	0.32		c0.09	c0.53	
v/s Ratio Perm									0.06			0.02
v/c Ratio	0.55	0.92dr		0.96	0.29		0.96	0.65	0.13	0.80	1.01	0.03
Uniform Delay, d1	70.5	60.4		69.2	51.5		70.0	28.5	20.6	66.5	36.2	17.5
Progression Factor	1.00	1.00		1.00	1.00		1.00	1.00	1.00	1.00	1.00	1.00
Incremental Delay, d2	7.4	5.5		60.6	0.2		42.9	1.3	0.2	12.2	24.0	0.0
Delay (s)	77.9	65.9		129.9	51.7		112.9	29.8	20.8	78.7	60.2	17.5
Level of Service	E	E		F	D		F	C	C	E	E	B
Approach Delay (s)		66.9			76.7			43.3			61.7	
Approach LOS		E			E			D			E	

Intersection Summary		
HCM 2000 Control Delay	57.8	HCM 2000 Level of Service
HCM 2000 Volume to Capacity ratio	0.95	E
Actuated Cycle Length (s)	152.5	Sum of lost time (s)
Intersection Capacity Utilization	95.8%	21.5
Analysis Period (min)	15	ICU Level of Service
		F

dr Defacto Right Lane. Recode with 1 though lane as a right lane.

c Critical Lane Group

HCM Unsignalized Intersection Capacity Analysis  
 102: SW Woodhaven Dr & SW Sunset Blvd

02/05/2019



Movement	EBL	EBT	EBR	WBL	WBT	WBR	NBL	NBT	NBR	SBL	SBT	SBR	
Lane Configurations													
Traffic Volume (veh/h)	121	389	26	5	416	73	12	0	1	38	1	64	
Future Volume (Veh/h)	121	389	26	5	416	73	12	0	1	38	1	64	
Sign Control	Free			Free			Stop			Stop			
Grade	-1%			1%			-2%			0%			
Peak Hour Factor	0.92	0.92	0.92	0.92	0.92	0.92	0.92	0.92	0.92	0.92	0.92	0.92	
Hourly flow rate (vph)	132	423	28	5	452	79	13	0	1	41	1	70	
Pedestrians													
Lane Width (ft)													
Walking Speed (ft/s)													
Percent Blockage													
Right turn flare (veh)													
Median type	None			None									
Median storage (veh)													
Upstream signal (ft)	648												
pX, platoon unblocked													
vC, conflicting volume	531			451			1220	1228	423	1190	1216	492	
vC1, stage 1 conf vol													
vC2, stage 2 conf vol													
vCu, unblocked vol	531			451			1220	1228	423	1190	1216	492	
tC, single (s)	4.1			4.1			7.1	6.5	6.2	7.1	6.5	6.2	
tC, 2 stage (s)													
tF (s)	2.2			2.2			3.5	4.0	3.3	3.5	4.0	3.3	
p0 queue free %	87			100			90	100	100	73	99	88	
cM capacity (veh/h)	1042			1120			125	156	635	149	159	577	
<b>Direction, Lane #</b>	<b>EB 1</b>	<b>EB 2</b>	<b>EB 3</b>	<b>WB 1</b>	<b>WB 2</b>	<b>NB 1</b>	<b>SB 1</b>						
Volume Total	132	423	28	5	531	14	112						
Volume Left	132	0	0	5	0	13	41						
Volume Right	0	0	28	0	79	1	70						
cSH	1042	1700	1700	1120	1700	133	278						
Volume to Capacity	0.13	0.25	0.02	0.00	0.31	0.11	0.40						
Queue Length 95th (ft)	11	0	0	0	0	9	46						
Control Delay (s)	9.0	0.0	0.0	8.2	0.0	35.4	26.4						
Lane LOS	A			A		E	D						
Approach Delay (s)	2.0			0.1		35.4	26.4						
Approach LOS						E	D						
<b>Intersection Summary</b>													
Average Delay			3.8										
Intersection Capacity Utilization			48.6%	ICU Level of Service		A							
Analysis Period (min)			15										

HCM Unsignalized Intersection Capacity Analysis  
 103: SW Timbrel Ln & SW Sunset Blvd

02/05/2019



Movement	EBT	EBR	WBL	WBT	NBL	NBR
Lane Configurations	↻		↻	↻	↻	
Traffic Volume (veh/h)	314	115	63	403	92	37
Future Volume (Veh/h)	314	115	63	403	92	37
Sign Control	Free			Free	Stop	
Grade	-1%			1%	0%	
Peak Hour Factor	0.91	0.91	0.91	0.91	0.91	0.91
Hourly flow rate (vph)	345	126	69	443	101	41
Pedestrians				1		
Lane Width (ft)				12.0		
Walking Speed (ft/s)				3.5		
Percent Blockage				0		
Right turn flare (veh)						
Median type	None			None		
Median storage (veh)						
Upstream signal (ft)	1264					
pX, platoon unblocked						
vC, conflicting volume			471		989	409
vC1, stage 1 conf vol						
vC2, stage 2 conf vol						
vCu, unblocked vol			471		989	409
tC, single (s)			4.1		6.4	6.2
tC, 2 stage (s)						
tF (s)			2.2		3.5	3.3
p0 queue free %			94		61	94
cM capacity (veh/h)			1086		256	640
Direction, Lane #	EB 1	WB 1	WB 2	NB 1		
Volume Total	471	69	443	142		
Volume Left	0	69	0	101		
Volume Right	126	0	0	41		
cSH	1700	1086	1700	310		
Volume to Capacity	0.28	0.06	0.26	0.46		
Queue Length 95th (ft)	0	5	0	57		
Control Delay (s)	0.0	8.5	0.0	26.1		
Lane LOS			A	D		
Approach Delay (s)	0.0	1.2		26.1		
Approach LOS				D		
Intersection Summary						
Average Delay			3.8			
Intersection Capacity Utilization			44.6%	ICU Level of Service	A	
Analysis Period (min)			15			



HCM Unsignalized Intersection Capacity Analysis  
 104: SW Main St/SW Ladd Hill Rd & SW Sunset Blvd

02/05/2019



Movement	EBL	EBT	EBR	WBL	WBT	WBR	NBL	NBT	NBR	SBL	SBT	SBR
Lane Configurations												
Sign Control	Stop			Stop			Stop			Stop		
Traffic Volume (vph)	27	133	134	52	103	52	99	231	39	69	377	41
Future Volume (vph)	27	133	134	52	103	52	99	231	39	69	377	41
Peak Hour Factor	0.89	0.89	0.89	0.89	0.89	0.89	0.89	0.89	0.89	0.89	0.89	0.89
Hourly flow rate (vph)	30	149	151	58	116	58	111	260	44	78	424	46

Direction, Lane #	EB 1	EB 2	WB 1	WB 2	NB 1	NB 2	SB 1	SB 2
Volume Total (vph)	30	300	58	174	111	304	78	470
Volume Left (vph)	30	0	58	0	111	0	78	0
Volume Right (vph)	0	151	0	58	0	44	0	46
Hadj (s)	0.50	-0.33	0.55	-0.22	0.50	-0.06	0.53	-0.05
Departure Headway (s)	8.4	7.6	8.7	7.9	8.0	7.5	7.8	7.2
Degree Utilization, x	0.07	0.63	0.14	0.38	0.25	0.63	0.17	0.94
Capacity (veh/h)	415	456	396	435	432	460	446	493
Control Delay (s)	10.8	21.3	11.9	14.6	12.5	21.3	11.2	53.2
Approach Delay (s)	20.4		13.9		18.9		47.2	
Approach LOS	C		B		C		E	

Intersection Summary

Delay	28.6
Level of Service	D
Intersection Capacity Utilization	59.9%
ICU Level of Service	B
Analysis Period (min)	15

HCM Unsignalized Intersection Capacity Analysis  
 105: SW Baker Rd/SW Murdock Rd & SW Sunset Blvd

02/05/2019



Movement	EBL	EBT	EBR	WBL	WBT	WBR	NBL	NBT	NBR	SBL	SBT	SBR
Lane Configurations												
Sign Control	Stop				Stop			Stop			Stop	
Traffic Volume (vph)	110	14	171	1	21	16	322	143	6	32	149	282
Future Volume (vph)	110	14	171	1	21	16	322	143	6	32	149	282
Peak Hour Factor	0.90	0.90	0.90	0.90	0.90	0.90	0.90	0.90	0.90	0.90	0.90	0.90
Hourly flow rate (vph)	122	16	190	1	23	18	358	159	7	36	166	313

Direction, Lane #	EB 1	EB 2	WB 1	NB 1	SB 1
Volume Total (vph)	122	206	42	524	515
Volume Left (vph)	122	0	1	358	36
Volume Right (vph)	0	190	18	7	313
Hadj (s)	0.50	-0.57	-0.21	0.16	-0.32
Departure Headway (s)	8.1	7.0	8.0	6.2	5.8
Degree Utilization, x	0.27	0.40	0.09	0.91	0.83
Capacity (veh/h)	430	495	413	564	601
Control Delay (s)	12.9	13.3	11.8	43.0	31.4
Approach Delay (s)	13.2		11.8	43.0	31.4
Approach LOS	B		B	E	D

Intersection Summary

Delay	30.9
Level of Service	D
Intersection Capacity Utilization	75.5%
ICU Level of Service	D
Analysis Period (min)	15

HCM Unsignalized Intersection Capacity Analysis  
 106: SW Pacific Hwy & SW Chapman Rd

02/05/2019

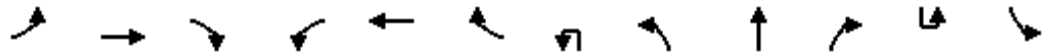

Movement	EBL	EBT	EBR	WBL	WBT	WBR	NBU	NBL	NBT	NBR	SBU	SBL
Lane Configurations		↕			↕			↕	↕			↕
Traffic Volume (veh/h)	20	7	12	46	5	54	1	8	1368	55	2	65
Future Volume (Veh/h)	20	7	12	46	5	54	1	8	1368	55	2	65
Sign Control		Stop			Stop				Free			
Grade		0%			0%				0%			
Peak Hour Factor	0.96	0.96	0.96	0.96	0.96	0.96	0.96	0.96	0.96	0.96	0.96	0.96
Hourly flow rate (vph)	21	7	13	48	5	56	0	8	1425	57	0	68
Pedestrians												
Lane Width (ft)												
Walking Speed (ft/s)												
Percent Blockage												
Right turn flare (veh)												
Median type												
Median storage veh												
Upstream signal (ft)												
pX, platoon unblocked							0.00				0.00	
vC, conflicting volume	3108	3819	1092	2714	3834	741	0	2229			0	1482
vC1, stage 1 conf vol	2321	2321		1470	1470							
vC2, stage 2 conf vol	787	1498		1245	2365							
vCu, unblocked vol	3108	3819	1092	2714	3834	741	0	2229			0	1482
tC, single (s)	7.6	6.5	6.9	7.6	6.5	6.9	0.0	4.1			0.0	4.1
tC, 2 stage (s)	6.6	5.5		6.6	5.5							
tF (s)	3.5	4.0	3.3	3.5	4.0	3.3	0.0	2.2			0.0	2.2
p0 queue free %	30	86	94	42	89	85	0	97			0	85
cM capacity (veh/h)	30	51	213	83	47	363	0	237			0	460
<b>Direction, Lane #</b>												
	EB 1	WB 1	NB 1	NB 2	NB 3	SB 1	SB 2	SB 3	SB 4			
Volume Total	41	109	8	950	532	68	1092	1092	44			
Volume Left	21	48	8	0	0	68	0	0	0			
Volume Right	13	56	0	0	57	0	0	0	44			
cSH	46	130	237	1700	1700	460	1700	1700	1700			
Volume to Capacity	0.90	0.84	0.03	0.56	0.31	0.15	0.64	0.64	0.03			
Queue Length 95th (ft)	91	130	3	0	0	13	0	0	0			
Control Delay (s)	240.2	104.1	20.7	0.0	0.0	14.2	0.0	0.0	0.0			
Lane LOS	F	F	C			B						
Approach Delay (s)	240.2	104.1	0.1			0.4						
Approach LOS	F	F										
<b>Intersection Summary</b>												
Average Delay			5.7									
Intersection Capacity Utilization			71.9%		ICU Level of Service				C			
Analysis Period (min)			15									

HCM Unsignalized Intersection Capacity Analysis  
 106: SW Pacific Hwy & SW Chapman Rd

02/05/2019



Movement	SBT	SBR
Lane Configurations	↑↑	↑
Traffic Volume (veh/h)	2098	42
Future Volume (Veh/h)	2098	42
Sign Control	Free	
Grade	0%	
Peak Hour Factor	0.96	0.96
Hourly flow rate (vph)	2185	44
Pedestrians		
Lane Width (ft)		
Walking Speed (ft/s)		
Percent Blockage		
Right turn flare (veh)		
Median type	Raised	
Median storage veh)	2	
Upstream signal (ft)		
pX, platoon unblocked		
vC, conflicting volume		
vC1, stage 1 conf vol		
vC2, stage 2 conf vol		
vCu, unblocked vol		
tC, single (s)		
tC, 2 stage (s)		
tF (s)		
p0 queue free %		
cM capacity (veh/h)		
Direction, Lane #		

HCM Unsignalized Intersection Capacity Analysis  
 107: SW Old Hwy 99W & SW Brookman Rd

02/05/2019



Movement	EBL	EBT	EBR	WBL	WBT	WBR	NBL	NBT	NBR	SBL	SBT	SBR
Lane Configurations		↕			↕			↕			↕	
Traffic Volume (veh/h)	10	110	1	1	100	2	1	1	2	1	1	1
Future Volume (Veh/h)	10	110	1	1	100	2	1	1	2	1	1	1
Sign Control		Free			Free			Stop			Stop	
Grade		0%			2%			2%			-2%	
Peak Hour Factor	0.82	0.82	0.82	0.82	0.82	0.82	0.82	0.82	0.82	0.82	0.82	0.82
Hourly flow rate (vph)	12	134	1	1	122	2	1	1	2	1	1	1
Pedestrians												
Lane Width (ft)												
Walking Speed (ft/s)												
Percent Blockage												
Right turn flare (veh)												
Median type		None			None							
Median storage (veh)												
Upstream signal (ft)												
pX, platoon unblocked												
vC, conflicting volume	124			135			285	284	134	286	284	123
vC1, stage 1 conf vol												
vC2, stage 2 conf vol												
vCu, unblocked vol	124			135			285	284	134	286	284	123
tC, single (s)	4.1			4.1			7.1	6.5	6.2	7.1	6.5	6.2
tC, 2 stage (s)												
tF (s)	2.2			2.2			3.5	4.0	3.3	3.5	4.0	3.3
p0 queue free %	99			100			100	100	100	100	100	100
cM capacity (veh/h)	1475			1462			665	622	920	664	623	933
<b>Direction, Lane #</b>	<b>EB 1</b>	<b>WB 1</b>	<b>NB 1</b>	<b>SB 1</b>								
Volume Total	147	125	4	3								
Volume Left	12	1	1	1								
Volume Right	1	2	2	1								
cSH	1475	1462	757	717								
Volume to Capacity	0.01	0.00	0.01	0.00								
Queue Length 95th (ft)	1	0	0	0								
Control Delay (s)	0.7	0.1	9.8	10.0								
Lane LOS	A	A	A	B								
Approach Delay (s)	0.7	0.1	9.8	10.0								
Approach LOS			A	B								
<b>Intersection Summary</b>												
Average Delay			0.6									
Intersection Capacity Utilization			22.4%		ICU Level of Service				A			
Analysis Period (min)			15									

HCM Unsignalized Intersection Capacity Analysis  
 108: SW Middleton Rd & SW Brookman Rd

02/05/2019



Movement	EBL	EBT	EBR	WBL	WBT	WBR	NBL	NBT	NBR	SBL	SBT	SBR
Lane Configurations		↕			↕			↕			↕	
Traffic Volume (veh/h)	10	92	16	12	80	6	15	6	8	7	10	4
Future Volume (Veh/h)	10	92	16	12	80	6	15	6	8	7	10	4
Sign Control		Stop			Stop			Free			Free	
Grade		-1%			1%			-2%			0%	
Peak Hour Factor	0.74	0.74	0.74	0.74	0.74	0.74	0.74	0.74	0.74	0.74	0.74	0.74
Hourly flow rate (vph)	14	124	22	16	108	8	20	8	11	9	14	5
Pedestrians		1			1						1	
Lane Width (ft)		12.0			12.0						12.0	
Walking Speed (ft/s)		3.5			3.5						3.5	
Percent Blockage		0			0						0	
Right turn flare (veh)												
Median type								None			None	
Median storage (veh)												
Upstream signal (ft)												
pX, platoon unblocked												
vC, conflicting volume	152	96	18	173	92	16	20			20		
vC1, stage 1 conf vol												
vC2, stage 2 conf vol												
vCu, unblocked vol	152	96	18	173	92	16	20			20		
tC, single (s)	7.1	6.5	6.2	7.2	6.5	6.2	4.2			4.1		
tC, 2 stage (s)												
tF (s)	3.5	4.0	3.3	3.6	4.0	3.3	2.3			2.2		
p0 queue free %	98	84	98	98	86	99	99			99		
cM capacity (veh/h)	715	782	1066	655	785	1068	1514			1608		
<b>Direction, Lane #</b>	<b>EB 1</b>	<b>WB 1</b>	<b>NB 1</b>	<b>SB 1</b>								
Volume Total	160	132	39	28								
Volume Left	14	16	20	9								
Volume Right	22	8	11	5								
cSH	805	779	1514	1608								
Volume to Capacity	0.20	0.17	0.01	0.01								
Queue Length 95th (ft)	18	15	1	0								
Control Delay (s)	10.6	10.6	3.8	2.4								
Lane LOS	B	B	A	A								
Approach Delay (s)	10.6	10.6	3.8	2.4								
Approach LOS	B	B										
<b>Intersection Summary</b>												
Average Delay			9.2									
Intersection Capacity Utilization			18.2%		ICU Level of Service					A		
Analysis Period (min)			15									

HCM Unsignalized Intersection Capacity Analysis  
 109: SW Oberst Rd/Site Access & SW Brookman Rd

02/05/2019



Movement	EBL	EBT	EBR	WBL	WBT	WBR	NBL	NBT	NBR	SBL	SBT	SBR
Lane Configurations		↕			↕			↕			↕	
Traffic Volume (veh/h)	57	51	0	4	67	36	4	0	4	23	0	32
Future Volume (Veh/h)	57	51	0	4	67	36	4	0	4	23	0	32
Sign Control		Free			Free			Stop			Stop	
Grade		-3%			2%			1%			0%	
Peak Hour Factor	0.69	0.69	0.69	0.69	0.69	0.69	0.69	0.69	0.69	0.69	0.69	0.69
Hourly flow rate (vph)	83	74	0	6	97	52	6	0	6	33	0	46
Pedestrians												2
Lane Width (ft)												12.0
Walking Speed (ft/s)												3.5
Percent Blockage												0
Right turn flare (veh)												
Median type		None			None							
Median storage (veh)												
Upstream signal (ft)												
pX, platoon unblocked												
vC, conflicting volume	151			74			421	403	74	383	377	125
vC1, stage 1 conf vol												
vC2, stage 2 conf vol												
vCu, unblocked vol	151			74			421	403	74	383	377	125
tC, single (s)	4.1			4.1			7.4	6.5	6.5	7.1	6.5	6.2
tC, 2 stage (s)												
tF (s)	2.2			2.2			3.7	4.0	3.5	3.5	4.0	3.3
p0 queue free %	94			100			99	100	99	94	100	95
cM capacity (veh/h)	1440			1538			456	505	927	546	523	929
<b>Direction, Lane #</b>	<b>EB 1</b>	<b>WB 1</b>	<b>NB 1</b>	<b>SB 1</b>								
Volume Total	157	155	12	79								
Volume Left	83	6	6	33								
Volume Right	0	52	6	46								
cSH	1440	1538	612	719								
Volume to Capacity	0.06	0.00	0.02	0.11								
Queue Length 95th (ft)	5	0	1	9								
Control Delay (s)	4.3	0.3	11.0	10.6								
Lane LOS	A	A	B	B								
Approach Delay (s)	4.3	0.3	11.0	10.6								
Approach LOS			B	B								
<b>Intersection Summary</b>												
Average Delay			4.2									
Intersection Capacity Utilization			23.0%		ICU Level of Service				A			
Analysis Period (min)			15									

HCM Unsignalized Intersection Capacity Analysis  
 110: SW Ladd Hill Rd & SW Brookman Rd

02/05/2019



Movement	EBL	EBR	NBL	NBT	SBT	SBR
Lane Configurations						
Traffic Volume (veh/h)	51	21	19	86	95	82
Future Volume (Veh/h)	51	21	19	86	95	82
Sign Control	Stop			Free	Free	
Grade	2%			-1%	0%	
Peak Hour Factor	0.78	0.78	0.78	0.78	0.78	0.78
Hourly flow rate (vph)	65	27	24	110	122	105
Pedestrians						
Lane Width (ft)						
Walking Speed (ft/s)						
Percent Blockage						
Right turn flare (veh)						
Median type						
				None	None	
Median storage (veh)						
Upstream signal (ft)						
pX, platoon unblocked						
vC, conflicting volume	332	174	227			
vC1, stage 1 conf vol						
vC2, stage 2 conf vol						
vCu, unblocked vol	332	174	227			
tC, single (s)	6.4	6.3	4.1			
tC, 2 stage (s)						
tF (s)	3.5	3.4	2.2			
p0 queue free %	90	97	98			
cM capacity (veh/h)	648	856	1353			
<b>Direction, Lane #</b>	<b>EB 1</b>	<b>NB 1</b>	<b>SB 1</b>			
Volume Total	92	134	227			
Volume Left	65	24	0			
Volume Right	27	0	105			
cSH	698	1353	1700			
Volume to Capacity	0.13	0.02	0.13			
Queue Length 95th (ft)	11	1	0			
Control Delay (s)	10.9	1.5	0.0			
Lane LOS	B	A				
Approach Delay (s)	10.9	1.5	0.0			
Approach LOS	B					
<b>Intersection Summary</b>						
Average Delay			2.7			
Intersection Capacity Utilization			29.7%	ICU Level of Service	A	
Analysis Period (min)			15			



Appendix H Mitigated Total Traffic Conditions  
Level of Service Worksheets

HCM Unsignalized Intersection Capacity Analysis  
 106: SW Pacific Hwy & SW Chapman Rd

01/30/2019



Movement	EBL	EBT	EBR	WBL	WBT	WBR	NBU	NBL	NBT	NBR	SBU	SBL
Lane Configurations		↔			←	↗		↘	↕			↖
Traffic Volume (veh/h)	30	3	2	47	3	93	4	8	1914	92	3	38
Future Volume (Veh/h)	30	3	2	47	3	93	4	8	1914	92	3	38
Sign Control		Stop			Stop				Free			
Grade		0%			0%				0%			
Peak Hour Factor	0.96	0.96	0.96	0.96	0.96	0.96	0.96	0.96	0.96	0.96	0.96	0.96
Hourly flow rate (vph)	31	3	2	49	3	97	0	8	1994	96	0	40
Pedestrians												
Lane Width (ft)												
Walking Speed (ft/s)												
Percent Blockage												
Right turn flare (veh)						8						
Median type									Raised			
Median storage (veh)									2			
Upstream signal (ft)												
pX, platoon unblocked							0.00				0.00	
vC, conflicting volume	2295	3338	576	2718	3307	1045	0	1169			0	2090
vC1, stage 1 conf vol	1232	1232		2058	2058							
vC2, stage 2 conf vol	1063	2106		660	1249							
vCu, unblocked vol	2295	3338	576	2718	3307	1045	0	1169			0	2090
tC, single (s)	7.7	6.5	6.9	7.6	6.5	7.2	0.0	4.1			0.0	4.1
tC, 2 stage (s)	6.7	5.5		6.6	5.5							
tF (s)	3.6	4.0	3.3	3.5	4.0	3.4	0.0	2.2			0.0	2.2
p0 queue free %	51	94	100	5	96	53	0	99			0	85
cM capacity (veh/h)	64	49	466	52	84	207	0	605			0	268

Direction, Lane #	EB 1	WB 1	NB 1	NB 2	NB 3	SB 1	SB 2	SB 3	SB 4
Volume Total	36	149	8	1329	761	40	576	576	17
Volume Left	31	49	8	0	0	40	0	0	0
Volume Right	2	97	0	0	96	0	0	0	17
cSH	65	153	605	1700	1700	268	1700	1700	1700
Volume to Capacity	0.55	0.97	0.01	0.78	0.45	0.15	0.34	0.34	0.01
Queue Length 95th (ft)	57	180	1	0	0	13	0	0	0
Control Delay (s)	114.2	106.7	11.0	0.0	0.0	20.8	0.0	0.0	0.0
Lane LOS	F	F	B			C			
Approach Delay (s)	114.2	106.7	0.0			0.7			
Approach LOS	F	F							

Intersection Summary

Average Delay	6.0
Intersection Capacity Utilization	74.9%
ICU Level of Service	D
Analysis Period (min)	15

HCM Unsignalized Intersection Capacity Analysis  
 106: SW Pacific Hwy & SW Chapman Rd

01/30/2019



Movement	SBT	SBR
Lane Configurations	↑↑	↑
Traffic Volume (veh/h)	1106	16
Future Volume (Veh/h)	1106	16
Sign Control	Free	
Grade	0%	
Peak Hour Factor	0.96	0.96
Hourly flow rate (vph)	1152	17
Pedestrians		
Lane Width (ft)		
Walking Speed (ft/s)		
Percent Blockage		
Right turn flare (veh)		
Median type	Raised	
Median storage veh)	2	
Upstream signal (ft)		
pX, platoon unblocked		
vC, conflicting volume		
vC1, stage 1 conf vol		
vC2, stage 2 conf vol		
vCu, unblocked vol		
tC, single (s)		
tC, 2 stage (s)		
tF (s)		
p0 queue free %		
cM capacity (veh/h)		
Direction, Lane #		

HCM Unsignalized Intersection Capacity Analysis  
 106: SW Pacific Hwy & SW Chapman Rd

01/30/2019



Movement	EBL	EBT	EBR	WBL	WBT	WBR	NBU	NBL	NBT	NBR	SBU	SBL
Lane Configurations		↔			←	↗		↘	↑			↘
Traffic Volume (veh/h)	20	7	12	46	5	54	1	8	1368	55	2	65
Future Volume (Veh/h)	20	7	12	46	5	54	1	8	1368	55	2	65
Sign Control		Stop			Stop				Free			
Grade		0%			0%				0%			
Peak Hour Factor	0.96	0.96	0.96	0.96	0.96	0.96	0.96	0.96	0.96	0.96	0.96	0.96
Hourly flow rate (vph)	21	7	13	48	5	56	0	8	1425	57	0	68
Pedestrians												
Lane Width (ft)												
Walking Speed (ft/s)												
Percent Blockage												
Right turn flare (veh)						8						
Median type									Raised			
Median storage (veh)									2			
Upstream signal (ft)												
pX, platoon unblocked							0.00				0.00	
vC, conflicting volume	3080	3819	1092	2714	3834	741	0	2229			0	1482
vC1, stage 1 conf vol	2321	2321		1470	1470							
vC2, stage 2 conf vol	759	1498		1245	2365							
vCu, unblocked vol	3080	3819	1092	2714	3834	741	0	2229			0	1482
tC, single (s)	7.6	6.5	6.9	7.6	6.5	6.9	0.0	4.1			0.0	4.1
tC, 2 stage (s)	6.6	5.5		6.6	5.5							
tF (s)	3.5	4.0	3.3	3.5	4.0	3.3	0.0	2.2			0.0	2.2
p0 queue free %	30	86	94	42	89	85	0	97			0	85
cM capacity (veh/h)	30	51	213	83	47	363	0	237			0	460

Direction, Lane #	EB 1	WB 1	NB 1	NB 2	NB 3	SB 1	SB 2	SB 3	SB 4
Volume Total	41	109	8	950	532	68	1092	1092	44
Volume Left	21	48	8	0	0	68	0	0	0
Volume Right	13	56	0	0	57	0	0	0	44
cSH	46	164	237	1700	1700	460	1700	1700	1700
Volume to Capacity	0.90	0.66	0.03	0.56	0.31	0.15	0.64	0.64	0.03
Queue Length 95th (ft)	91	95	3	0	0	13	0	0	0
Control Delay (s)	239.7	63.3	20.7	0.0	0.0	14.2	0.0	0.0	0.0
Lane LOS	F	F	C			B			
Approach Delay (s)	239.7	63.3	0.1			0.4			
Approach LOS	F	F							

Intersection Summary		
Average Delay		4.5
Intersection Capacity Utilization	73.5%	ICU Level of Service
Analysis Period (min)	15	D

HCM Unsignalized Intersection Capacity Analysis  
 106: SW Pacific Hwy & SW Chapman Rd

01/30/2019



Movement	SBT	SBR
Lane Configurations	↑↑	↑
Traffic Volume (veh/h)	2098	42
Future Volume (Veh/h)	2098	42
Sign Control	Free	
Grade	0%	
Peak Hour Factor	0.96	0.96
Hourly flow rate (vph)	2185	44
Pedestrians		
Lane Width (ft)		
Walking Speed (ft/s)		
Percent Blockage		
Right turn flare (veh)		
Median type	Raised	
Median storage veh)	2	
Upstream signal (ft)		
pX, platoon unblocked		
vC, conflicting volume		
vC1, stage 1 conf vol		
vC2, stage 2 conf vol		
vCu, unblocked vol		
tC, single (s)		
tC, 2 stage (s)		
tF (s)		
p0 queue free %		
cM capacity (veh/h)		
Direction, Lane #		

## Appendix I Turn Lane Assessment

Appendix H: Turn Lane Assessment

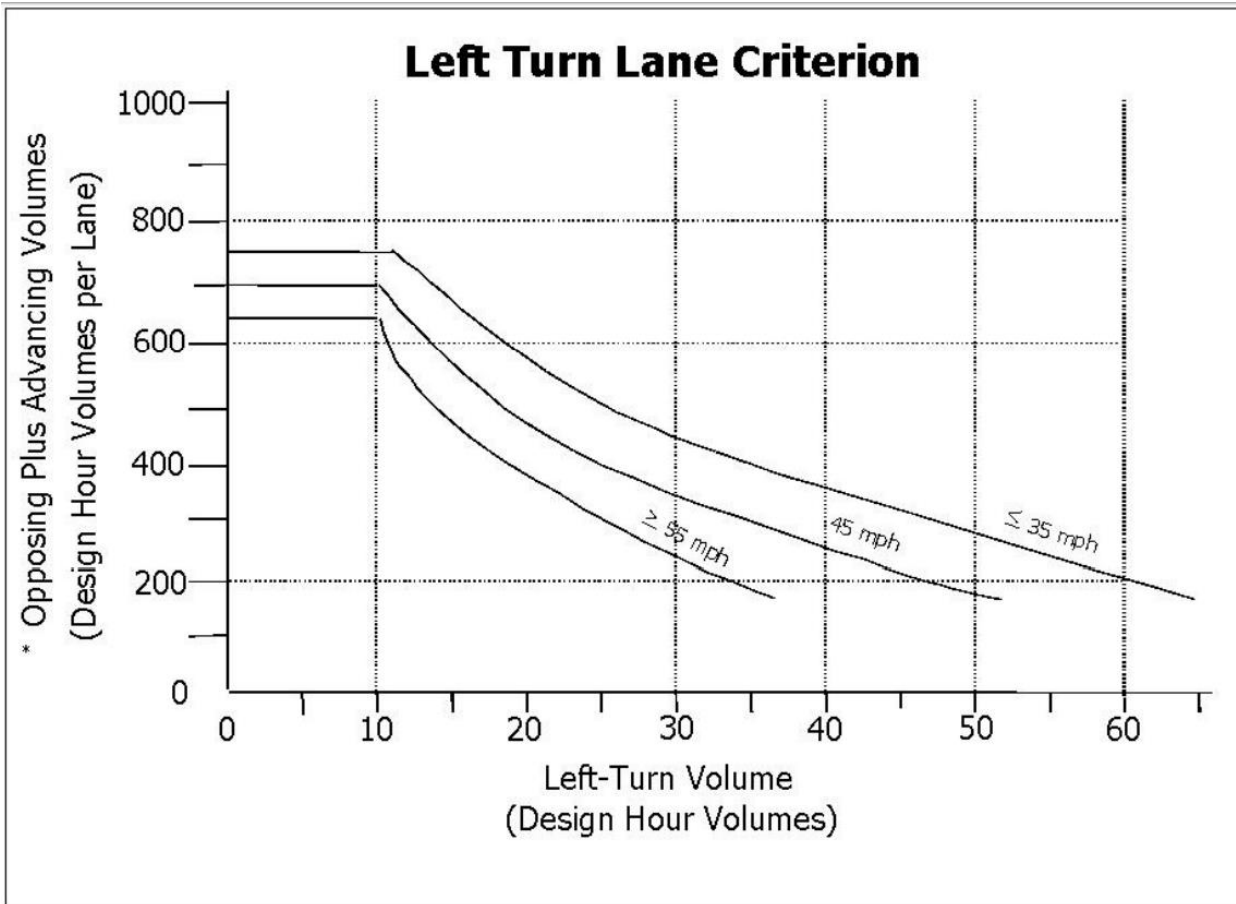

\*(Advancing Volume/Number of Advancing Through Lanes) + (Opposing Volume/Number of Opposing Through Lanes)

Opposing left turns are not counted as opposing volumes

Scenario	Eastbound Left-Turn Volume	Opposing Plus Advancing Volumes	Meets Criteria?
Year 2020 Total Traffic, Weekday AM Peak Hour	18	208	No
Year 2020 Total Traffic, Weekday PM Peak Hour	57	211	No